	VT-0017R110	000	01-18	CWH
	Manually Defueling A Chart LNG Vehicle Tank			

OVERVIEW

During maintenance and repairs of Chart LNG tanks it may be necessary to defuel the tanks. This document is intended provide necessary steps for this process. Chart recommends when defueling that LNG fuel be transferred into a suitable cryogenic container.

PARTS NEEDED

A cryogenic rated transfer hose and assorted fittings to attach to liquid valve outlet will be needed. Additionally, a cryogenic tank for fuel may be needed according to where fuel is being transferred.

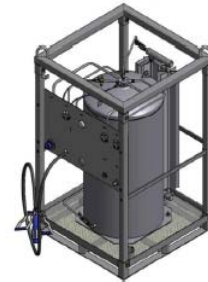

SAFETY

It is recommended to perform defueling and depressurizing of tanks in a well ventilated area so as to avoid gas from concentrating in an area. When air to fuel mixture is correct, concentrated gases become flammable. Insure truck’s parking brake is applied, wheels chocked, tank is grounded, and ignition switch is in the “off” position. Check for leaks and repair as needed. Wear proper PPE as needed for defueling and depressurizing of tanks & testing.



This procedure is intended for use by trained technicians with experience on systems using LNG. Review all applicable safety documents before beginning this procedure.



VT-0017R110

000

01-18

CWH

Manually Defueling A Chart LNG Vehicle Tank

De-fueling

If repairs are going to be made to a Chart LNG tank it is required for certain components, and recommended for all components to defuel the LNG system and bring tank pressure to 0 bar. Defueling will always be done through the red handled liquid valve. Attempting to defuel through the grey vent valve will only remove gas pressure from the tank and leave LNG in the tank at 0 bar or at low pressures making it difficult to remove the LNG.

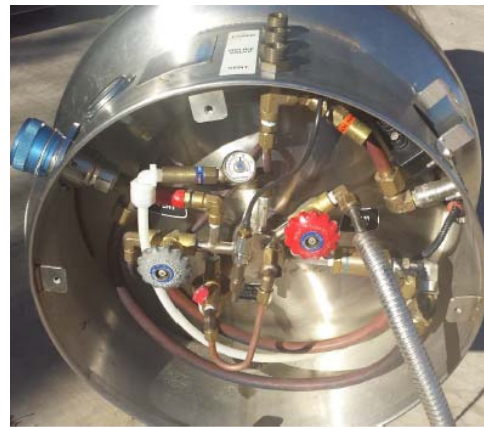

NOTE: If when beginning the defueling process the tank pressures are at 0-2 bar and there is LNG in the tank, skip to: **Tanks with LNG at 0-2 bar pressure**



This procedure is intended for use by trained technicians with experience on systems using LNG. Review all applicable safety documents before beginning this procedure.



VT-0017R110

000

01-18

CWH

Manually Defueling A Chart LNG Vehicle Tank

Step 1: Close the red handled liquid valve and grey vent valve and start the truck's engine. If the truck has a dual tank system, close the red and gray valves on both tanks.

Step 2: Allow the engine operate until it shuts down. At this point the majority of the fuel system pressure will be removed, but some residual pressure will remain.

Step 3: Slowly loosen a flared connection downstream of the exit of the liquid (red) manual valve, letting the residual pressure vent to the atmosphere.

Step 4: If the tank is a nonintegrated type, remove the excess flow valve (item #3 nonintegrated tank) and outlet tubing (item 27).

Integrated Tank

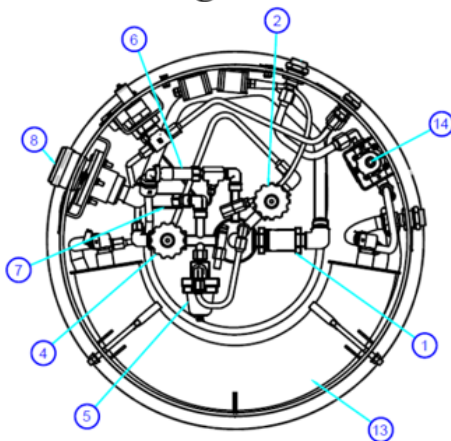

Non-Integrated Tank

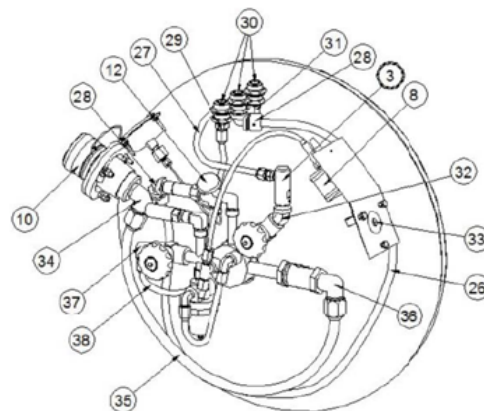

Step 5: Attach a 90 degrees brass elbow (Chart PN 11674271) at the exit of the liquid (red) manual valve. The fitting on the elbow is a 3/8" MPT X 1/2" flare. Install a suitable defueling hose or tubing to the fitting outlet.

Step 6: In the case where there is another vessel to transfer the contents to (preferable option), connect the transfer hose to the fill receptacle of the empty/receiving vessel. If the empty/receiving vessel has positive pressure inside, vent the empty/receiving vessel to 0 bar. Note: for the fuel transfer to work properly, the delta pressure in between the two vessels will need to be 2 bar or greater. Higher pressure differential will ensure faster fuel flow. Check this pressure during the transfer and correct when necessary.

Step 7: Slowly open the liquid manual valve on the tank to be emptied. The receiving tank will most likely need to be vented as the transfer progresses to maintain the pressure differential between the two tanks. A change in the sound of fuel running through the hose will be noticed when the tank is liquid empty. Continue defueling the vapor pressure until the tank reaches 0 bar and no gas flow is coming through the hose.

This procedure is intended for use by trained technicians with experience on systems using LNG. Review all applicable safety documents before beginning this procedure.

	VT-0017R110	000	01-18	CWH
	Manually Defueling A Chart LNG Vehicle Tank			

Step 8: Note: when the liquid transfer is complete a whistling noise may be heard flowing through the transfer hose, this is a good indication that the majority of the liquid has transferred and gas is flowing.

Step 9: When the transfer is complete, close the liquid manual valve and remove the fuel transfer hose.

Step 10: Before beginning repairs and removing any parts from the tank plumbing, reopen the liquid (red) valve to ensure no residual LNG in the tank has boiled off and created pressure. Ensure the pressure gauge reads 0 bar. Do not leave the tank or valves open to atmosphere for extended periods of time.

Step 11: Once repairs have been made, ensure all lines and parts are replaced and tight. Open the red liquid valve on the tank(s) and leak test any components removed or loosened.

Step 12: If the truck has a dual tank system and work only needs to be performed on one tank, only de-fuel the tank that needs to be worked on. This will save fuel and expense as the other tank will retain its fuel level. This should allow the truck to drive away to the fuel station (depending on fuel level in tank not de-fueled and distance to fuel station) so it doesn't have to be towed. See information below regarding transferring fuel.

Tanks with LNG at 0-2 bar pressure

If when beginning the defueling process the tank pressures are at 0-2 bar and LNG needs to be removed, nitrogen gas will need to be added to increase tank pressure.



This procedure is intended for use by trained technicians with experience on systems using LNG. Review all applicable safety documents before beginning this procedure.



VT-0017R110

000

01-18

CWH

Manually Defueling A Chart LNG Vehicle Tank

WARNING: Only use nitrogen gas. Introduction of other gases into the LNG tank may create a flammable mixture inside of the tank.

Note: Using a Vent Connector attached to a nitrogen tank will allow nitrogen gas to be introduced into the tank through the Male QDV Vent to build pressure in the LNG tank. If a Vent Connector is not available, connecting directly to the grey vent valve will give the same results.

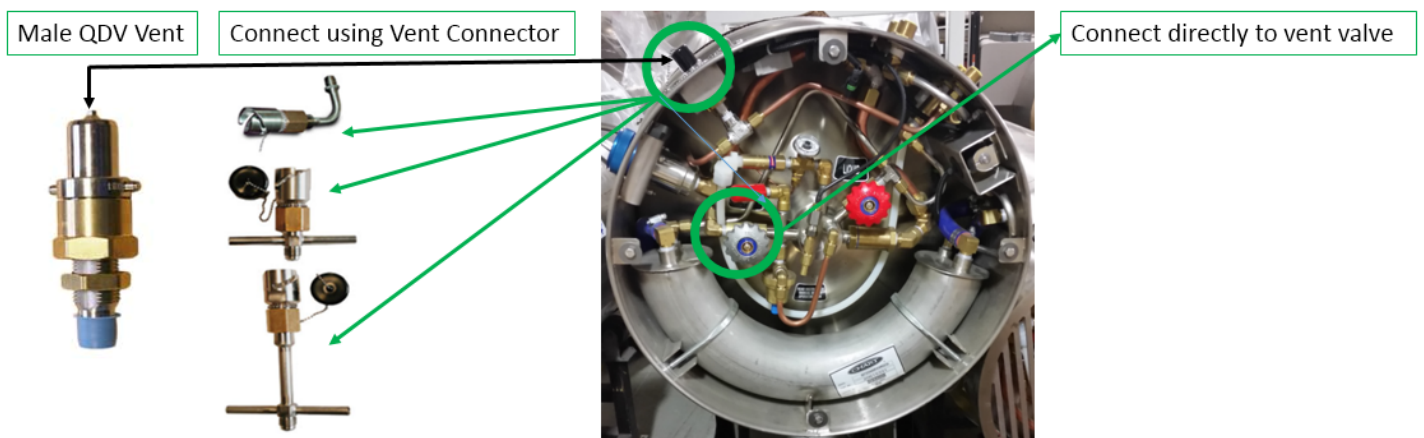

Step 14: Close red handled liquid and grey handled vent valves.

a: If using Vent Connector, attach connector to Male QDV Vent, open grey vent valve, and begin introducing nitrogen gas into tank until LNG tank pressure gauge indicates 7 bar. After pressure is reached, close grey vent valve, close nitrogen supply valve, and proceed to **Step 1**.

b: If connecting directly to grey vent valve, loosen a fitting on the vapor plumbing to release pressure in the line to 0 bar. Remove necessary fittings to make a connection between nitrogen gas source and LNG tank. Open grey vent valve, and begin introducing nitrogen gas into tank until LNG tank pressure gauge indicates 7 bar. After pressure is reached, close grey vent valve, close nitrogen supply valve, and proceed to **Step 1**.

This procedure is intended for use by trained technicians with experience on systems using LNG. Review all applicable safety documents before beginning this procedure.



VT-0017R110

000

01-18

CWH

Manually Defueling A Chart LNG Vehicle Tank

Transferring Fuel between Tanks

Normally on a dual tank system some of the LNG fuel can be transferred from one tank to another. This may allow a truck to be driven to the fuel station and avoid an expensive tow bill for the customer. If either or both the tanks need to be defueled for service, follow the appropriate instructions below.

Integrated Tank

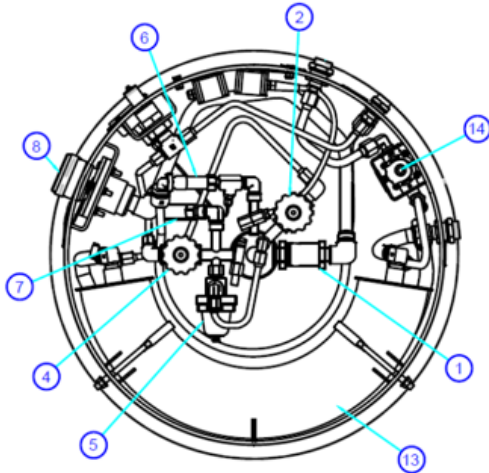

Non-Integrated Tank

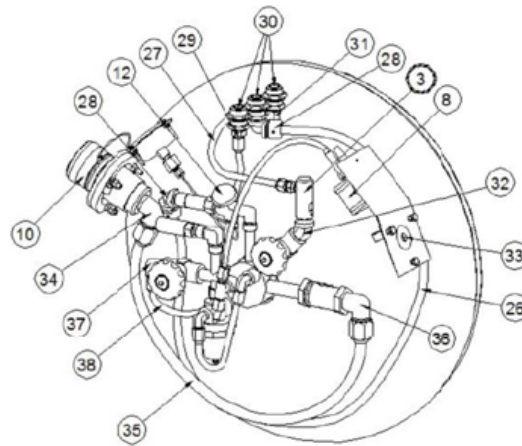

Integrated Tanks

De-fueling driver side only – Close the liquid (2) and vent (4) valves on both tanks. Afterward the driver's side tank can be defueled as mentioned above in the defueling section. Once repairs are complete open the driver's side tanks liquid valve, then slowly open the passenger's side tank liquid valve to allow fuel to transfer into the driver's side tank. If the excess flow valve (item 3 above illustration) sets (stops the flow of fuel) while transferring fuel, close the liquid valve until you hear the excess flow valve reset. After it resets re-open the liquid valve. Once both tanks reach equal pressures no more fuel will flow. If necessary the passenger's side tank can now be defueled.

De-fueling passenger's side only - Close the liquid and vent valves on both tanks. Afterward the passenger's side tank can be defueled as mentioned in the defueling procedure above. Once repairs are complete slowly open both passengers' side tank liquid and vent valves. Fuel will not transfer from the driver's side to the passenger's side due a one way fuel check valve inside the shroud of the integrated tank. However any remaining fuel in the driver's side tank will not be lost when the passenger's side is defueled, which will allow the truck to be operable.

This procedure is intended for use by trained technicians with experience on systems using LNG. Review all applicable safety documents before beginning this procedure.



VT-0017R110

000

01-18

CWH

Manually Defueling A Chart LNG Vehicle Tank

De-fueling both tanks - Close the liquid and vent valves on both tanks. Afterward the driver's side tank can be defueled as mentioned in the defueling procedure above. Make repairs to driver side tank. If needed, reduce passenger side tank pressure to below economizer set point. Open driver's side red valve, then slowly open the passenger's side tank liquid valve to allow fuel to transfer into the driver's side tank. If the excess flow valve (item 3 above illustration) sets while transferring fuel close the passenger's side liquid valve until you hear the excess flow valve reset. Once both tanks reach equal pressures no more fuel will flow. Close off both tanks liquid valves and defuel the passenger's side tank as mentioned above. Any transferred fuel will remain in the driver's side tank and may be enough to get the truck to a local fuel station.

Non-Integrated Tank Systems

Defueling nonintegrated tanks - The same procedures as above can be used. However it should be noted that you will be able to transfer fuel from a driver's side tank to a passenger's side tank, or vice versa, because a one way fuel line check valve is not used on nonintegrated tanks.

Integrated Tank

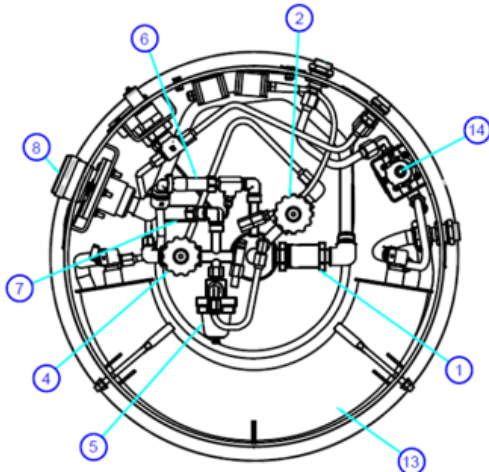

Non-Integrated Tank

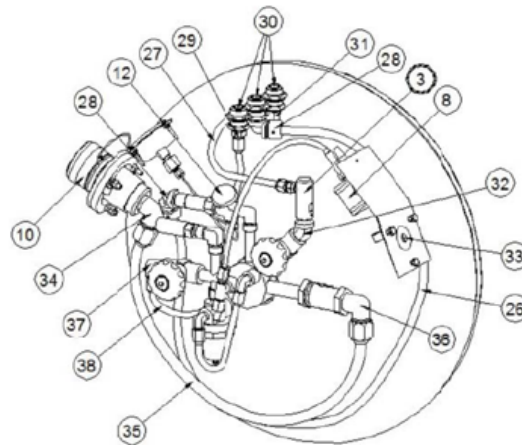

This procedure is intended for use by trained technicians with experience on systems using LNG. Review all applicable safety documents before beginning this procedure.