

### INSTALLATION MANUAL

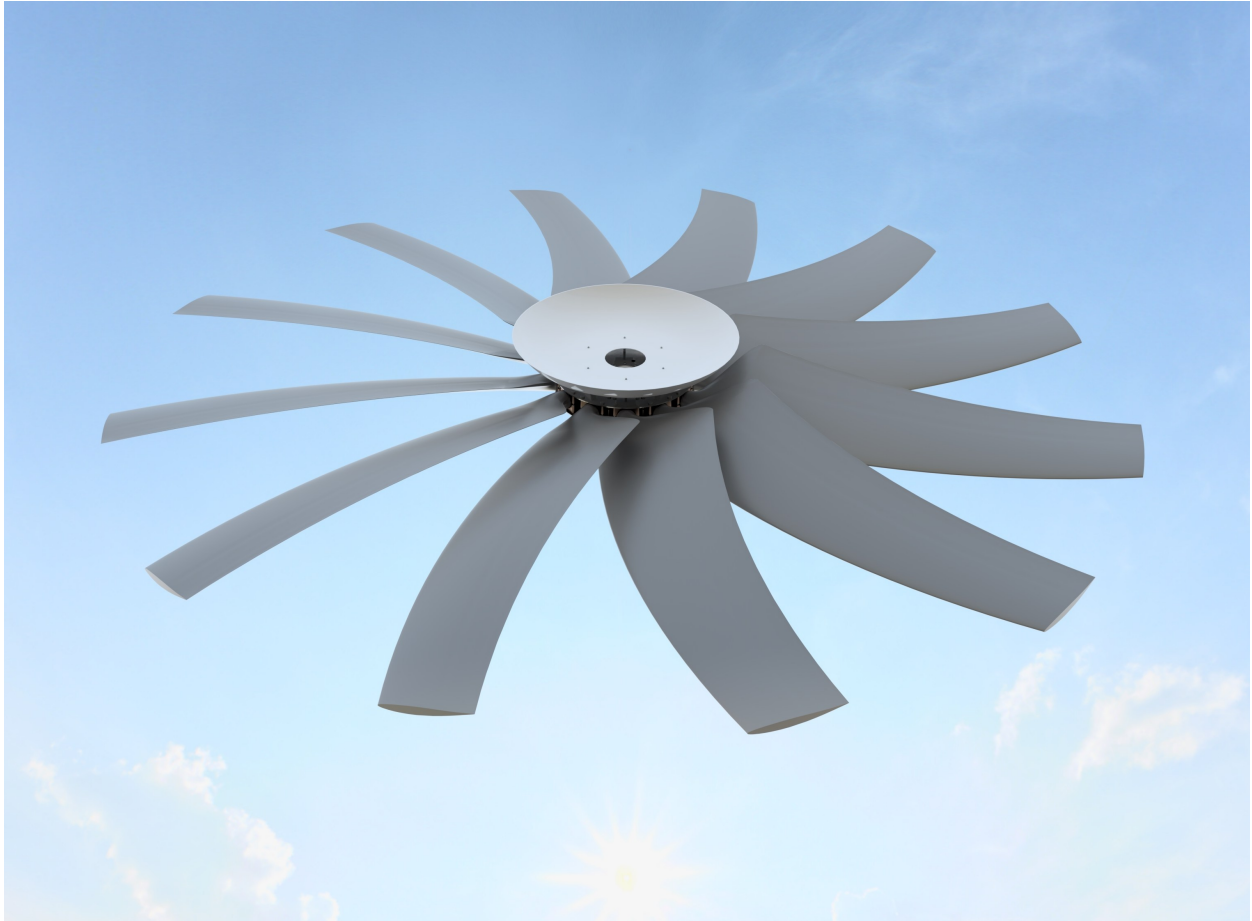

### Adjustable Pitch Fan Assembly 26' - 30' Diameter

#### *Hudson Tuf-Lite IV<sup>®</sup> fan blades*

Hudson Tuf-Lite IV<sup>®</sup> fan blades are of single piece fiberglass reinforced plastic (FRP) construction optimized for performance, reliability, noise, and cost effectiveness. Tuf-Lite IV<sup>®</sup> fan blades are constructed of light weight, corrosion-resistant, fiberglass reinforced vinyl-ester resin, with materials, thickness, and processes determined from finite element analysis modeling. Tuf-Edge<sup>®</sup> provides superior resistance against leading edge erosion and UV inhibited pigmentation yields longer life. The individually balanced blades can be replaced independently - matched sets are not required.

## RECOMMENDED TOOLS

- Long T-Handle Allen Wrench Set (3/16" to 3/8")
- Medium Size Flat Head Screw Driver
- Brass Ball Peen Hammer
- Flat Bastard File
- 240 Grit Sand Paper
- Anti-Seize Lubricant
- WD-40
- 12" Crescent Wrench
- Shop Towels
- Exact-A-Pitch® Digital Protractor (P/N 62375)
- 25 ft. Measuring Tape
- Pencil or Marker
- Open/Box End Wrench Set (1/2" - 1-1/2")
- Socket Set for 1/2" Drive (1/2" - 1-1/2")
- Torque Wrench(s) Rated for 0-200 ft-lb.

## INSTALLATION PROCEDURES

### ASSEMBLY WITH BUSHING

Clean all mating surfaces between hub, bushing and shaft. All grease and lubricant should be removed, leaving the mating surfaces dry.

If there is no shoulder on shaft to prevent bushing from sliding down shaft, slide spacer/sleeve (not provided) on shaft before bushing or use a thrust retainer (optional equipment) on top of hub. Slide bushing and key onto shaft until flush with end of shaft. The shaft size determines the bushing type (R2, S2, or U1). Lock bushing on shaft by tightening the set screw in flange with an Allen Wrench. Line up key and set hub on bushing. Engage the three (3) cap screws in flange of bushing into hub spool, using a torque wrench with a socket, and tighten evenly. Use the following table to determine the proper tools and torque values.

Bushing Size	Allen Wrench Size	Cap Screw Size	Socket Size	Torque (ft-lb) Dry
R2	3/16"	3/8"	9/16"	29
S2	3/16"	1/2"	3/4"	70
U1	3/16"	5/8"	15/16"	140

### ASSEMBLY WITH STRAIGHT SHAFT (NO BUSHING)

Clean all mating surfaces between the hub and the shaft. If there is no shoulder on shaft to prevent hub from sliding down shaft, slide spacer/sleeve (not provided) on shaft before hub or use a thrust retainer (optional equipment) on top of hub. Install key in shaft. Line up key and keyway and set hub on shaft. Tighten set screw(s) in hub.

### ASSEMBLY WITH TAPERED SHAFT (NO BUSHING REQUIRED)

Clean all mating surfaces between the hub and shaft.

Align keyways and install hub. Install retainer plate and cap screw(s) with lock washer(s). Shaft size determines what size cap screw is necessary. Using a torque wrench with a socket, evenly tighten cap screw to recommended standard per table below.

Cap Screw Size	Socket Size	Torque Value (ft-lb)	
		Lubricated	Dry
5/8" NC	15/16"	100	110
3/4" NC	1-1/8"	125	130
1" NC	1-1/2"	150	160

NOTE: Retaining arrangement varies with gear shaft design.

## SEAL DISC HARDWARE INSTALLATION

\*Seal disc mounting hardware must be installed BEFORE installing blades and blade clamps, due to limited access to seal disc bolt holes.

Install seal disc spacer as shown in Figures 1 and 2. Install 3/8" bolts on the top hub plate with the threaded portion pointing upwards. Place spacer on bolt, then flat washer, and then tighten 3/8" NC nut to recommended standard of 15 ft-lb (lubricated) or 20 ft-lb (dry).

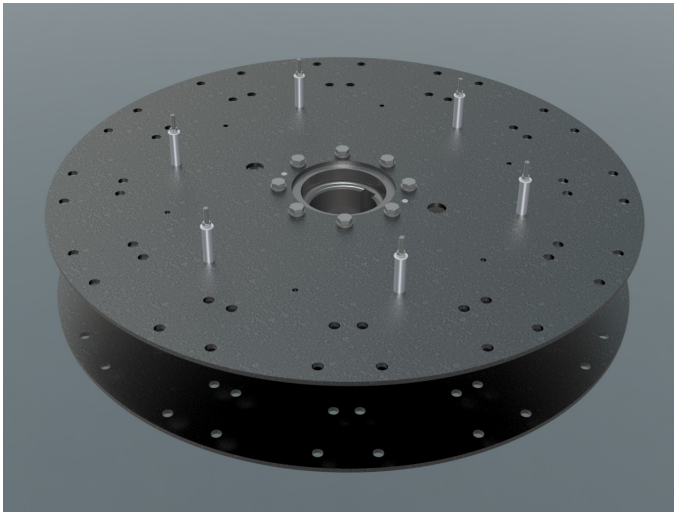

Figure 1

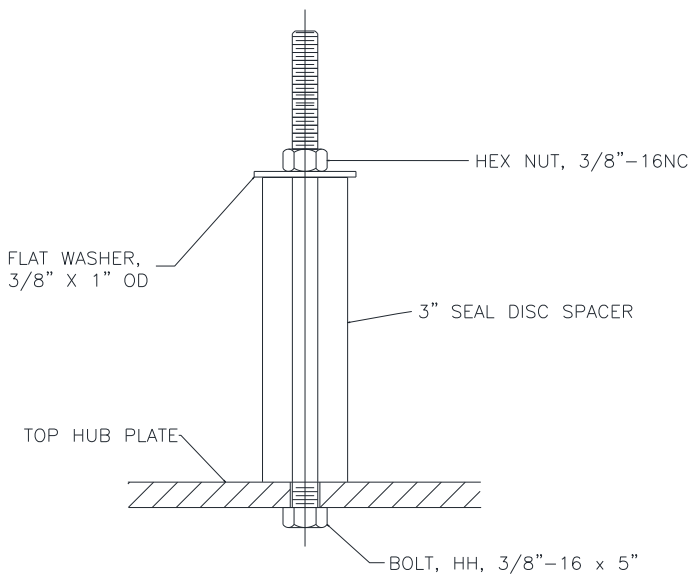

Figure 2

## THRUST RETAINER (optional equipment)

Install proper load bolt (not provided) into top of fan shaft and tighten (See Figure 3). Install thrust retainer channel on top hub plate using existing hub spool cap screws. Torque cap screws to 60-65 ft-lb. Install thrust retainer eyebolt and jam nut. Hand tighten eyebolt. Tighten jam nut securely against top of thrust retainer channel.

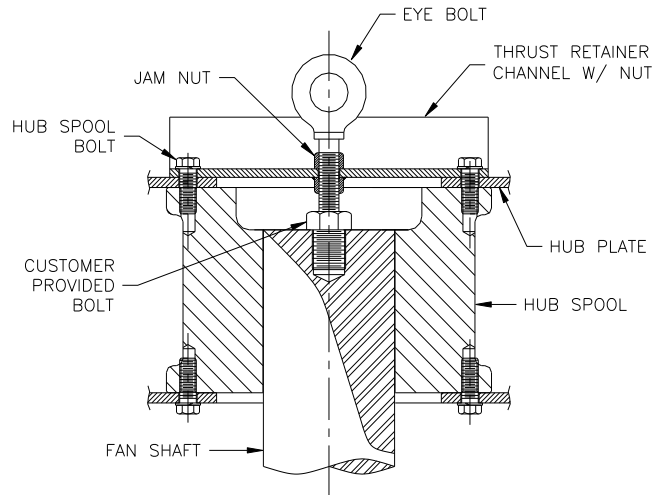

Figure 3

## BLADE INSTALLATION

Remove blade clamp bolts, nuts, lock washers, and blade clamp halves from hub. Assemble blade clamp halves over groove in blade neck, and install into hub (See Figure 4). The thick leading edge will be to your left and thin trailing edge will be to your right as you stand at end of blade.

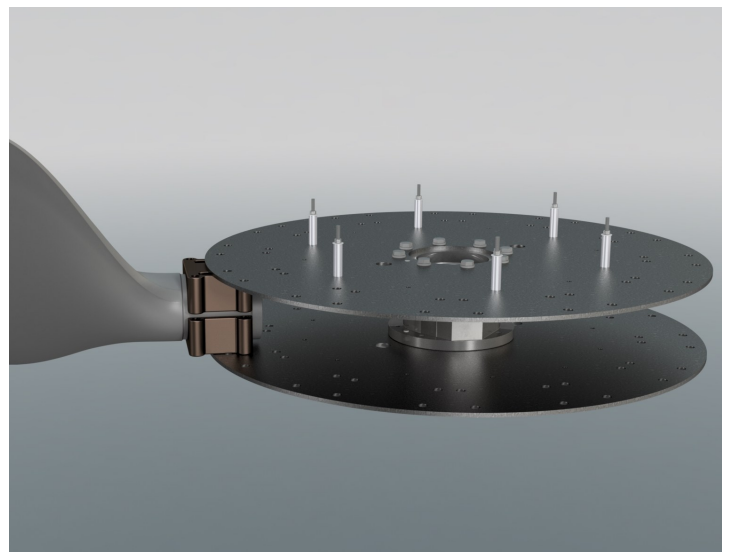

Figure 4

Install clamp bolts through hub plates and blade clamp, putting bolt heads on top, lock washers and nuts on bottom. Tighten lightly (See Figure 5).

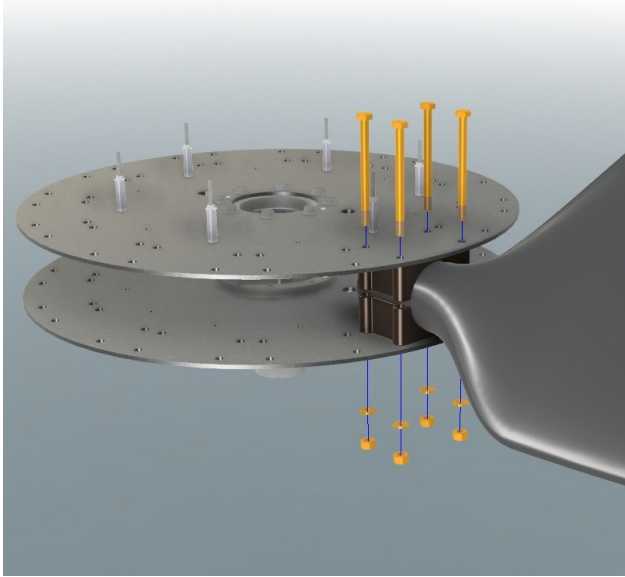

Figure 5

## SET PITCH AND TRACK

Use Hudson EXACT-A-PITCH<sup>®</sup> digital protractor (See Figure 6) to set blade pitch. Mount protractor on the trailing edge of the blade and ensure that protractor is long enough to reach at least half across the blade chord. Place the protractor approximately 1" from tip of blade. Note pitch on protractor. Rotate fan 360°, noting high and low pitch readings. Locate place where pitch reading is at mid-point between high and low readings, and set pitch at that point.

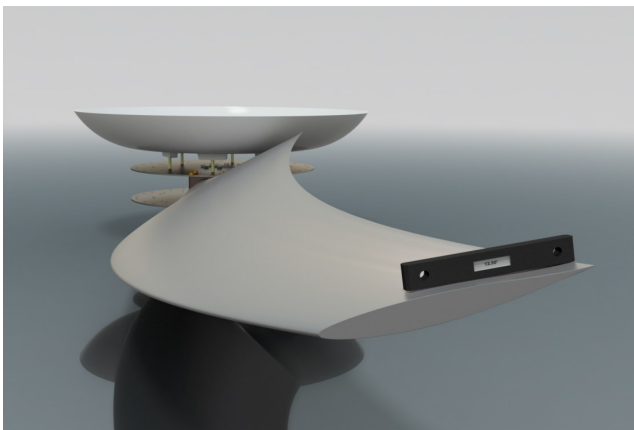

Figure 6

Rotate blade in clamp until digital protractor shows specified pitch angle to within  $\pm 0.2^\circ$ . *Fan pitch angle is shown on fan specification sheet for design duty.* After desired pitch angle is set, raise and lower end of fan blade and find midpoint of blade travel. Hold blade at the midpoint. Pull blade outward so that the blade neck flange rests against the back of the blade clamps. Push blade to the right to remove all slack.

Use torque wrench to tighten clamp bolts per Table 1 below:

Table 1: Clamp Bolt Torque Values

Clamp Bolt Type	Torque Value (ft-lb)	
	Lubricated	Dry
316 SS	130	n/a
Grade 8, Galv.	250	280

Re-check pitch setting. Blade must be set within  $\pm 0.2^\circ$  of desired pitch angle. Tighten clamp bolts evenly. **DO NOT OVERTORQUE CLAMP BOLTS.**

When bolts are tightened, hold a pencil against top end of blade and mark the level onto a fixed object, such as a pole or the fan ring.

Install remaining blades at same place as first blade, following the instructions above. After tightening bolts, mark top end of each blade in same place first blade was marked. If marks differ by 1" or more, adjust blade.

## CHECK TRACK

After fan is installed in fan stack cylinder ring, outline top side of each blade onto fan stack cylinder ring with a marker (See Figure 7). The difference between levels of highest and lowest outlines should be within  $\pm 2"$ . Correct blade track by loosening clamp bolts and adjusting blade to match track of other blades. Re-tighten bolts and re-check track and pitch angle setting. Re-tighten blade clamp bolts to recommended standard per Table 1.

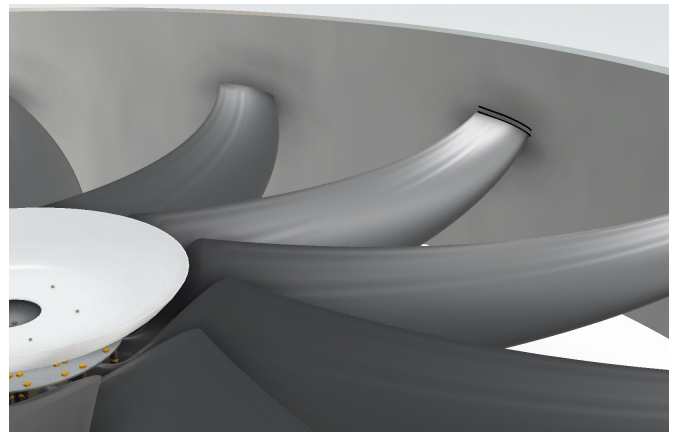

Figure 7

## CHECK SWEEP

Measure the distance from trailing edge at blade tip of one blade to trailing edge at blade tip of the adjacent blade (See Figure 7a). This distance should be within 1" of each other for all successive blades. Correct blade sweep by loosening clamp bolts and adjusting blade to match sweep of other blades. Re-tighten bolts and re-check sweep and pitch angle setting. Re-tighten blade clamp bolts to recommended standard per Table 1.

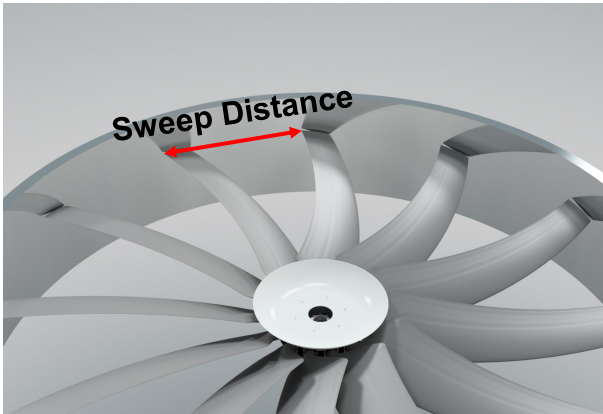

Figure 7a

## SEAL DISC ASSEMBLY & INSTALLATION

After installing blades, seal disc should be installed on the previously installed seal disc hardware as shown in Figure 8 for 6 to 8 bladed hubs. For 9 to 12 bladed hubs, first install self adhesive rubber gaskets on both flanges of one seal disc half. Bolt two halves of seal disc together, using 3/8" NC bolts, flat washer, lock washer, and nut. Torque to 15 ft-lb (lubricated) and 20 ft-lb (dry). Then, install seal disc on the previously installed seal disc hardware as shown in Figure 8.

Install flat washer, then place seal disc on top. Install another flat washer, lock washer, and nut on top. Tighten 3/8" NC nut to recommended standard of 15 ft-lb (lubricated) or 20 ft-lb (dry). If difficulty is encountered, loosen bolts on seal flanges until seal disc can be mounted, then re-tighten

**NOTE:** The purpose of the seal disc is to prevent adverse air recirculation at non-aerodynamic portion of the fan blade, hence increasing efficiency.

Note: Refer to instructions included with seal disc for further details.

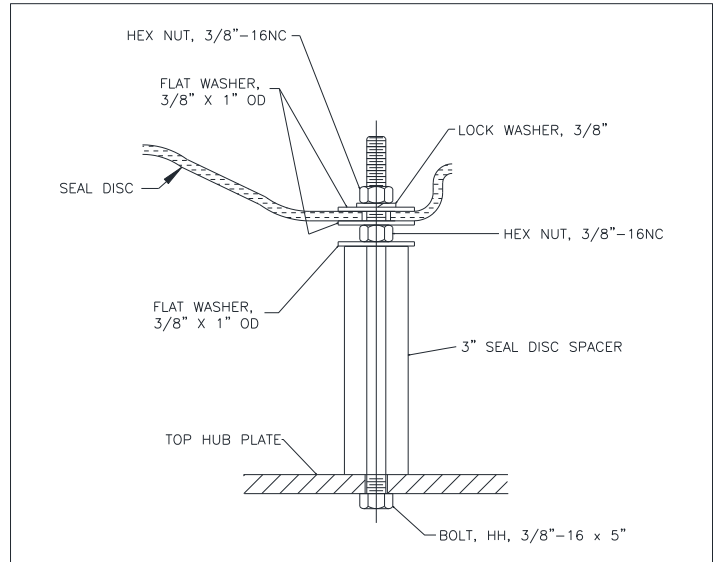

Figure 8

## CHECKING TIP CLEARANCE

Rotate fan in position inside fan stack to check tip clearance (See Figure 9). The recommended tip clearance is shown in table below. Check for spots where fan blade clearance is not within the recommended tolerance. If necessary, adjust fan stack by shimming to obtain proper clearance.

Fan Diameter	Stack Type	Tip Clearance
26ft - 30ft	FRP/Metal	1" to 1-1/2"
	Concrete	3/8" to 1-1/2"



Figure 9

## OPERATING INSTRUCTIONS

Start fan and check rotation. Viewed from top (discharge), fan blades should rotate clockwise.

It is mandatory to re-verify the blade clamp torque and blade pitch after the initial 10-15 minutes of cold operation (i.e., the fan doesn't need to be exposed to the working temperature of the process). If necessary, re-pitch and/or re-torque blades at the same settled track position after initial cold operation. This will ensure that the blades are well settled within the clamps after the centrifugal forces have acted.

Check motor power consumption to be sure fan is pulling desired load. *CAUTION: If positive pitch is set in summer to use all available motor amps (nameplate rating), motor could be overloaded in winter.* Design pitch angles usually do not use all of the available motor horsepower. This ensures that the motors will not be overloaded at low winter temperatures.

For the fans that have remained idle (such as a shut-down or turn-around), it is highly recommended to re-verify the torque on the blade clamps before putting it back into operation.

## OPERATIONAL LIMITS

Temperature: -100F to 220F Continuous,  
250F Intermittent

Wind speed: 75mph, shut down fan if forecast is higher



HUDSON PRODUCTS CORPORATION  
 Adjustable Pitch Fan Assembly 26' thru 30' Diameter  
 Series 5000M HUB

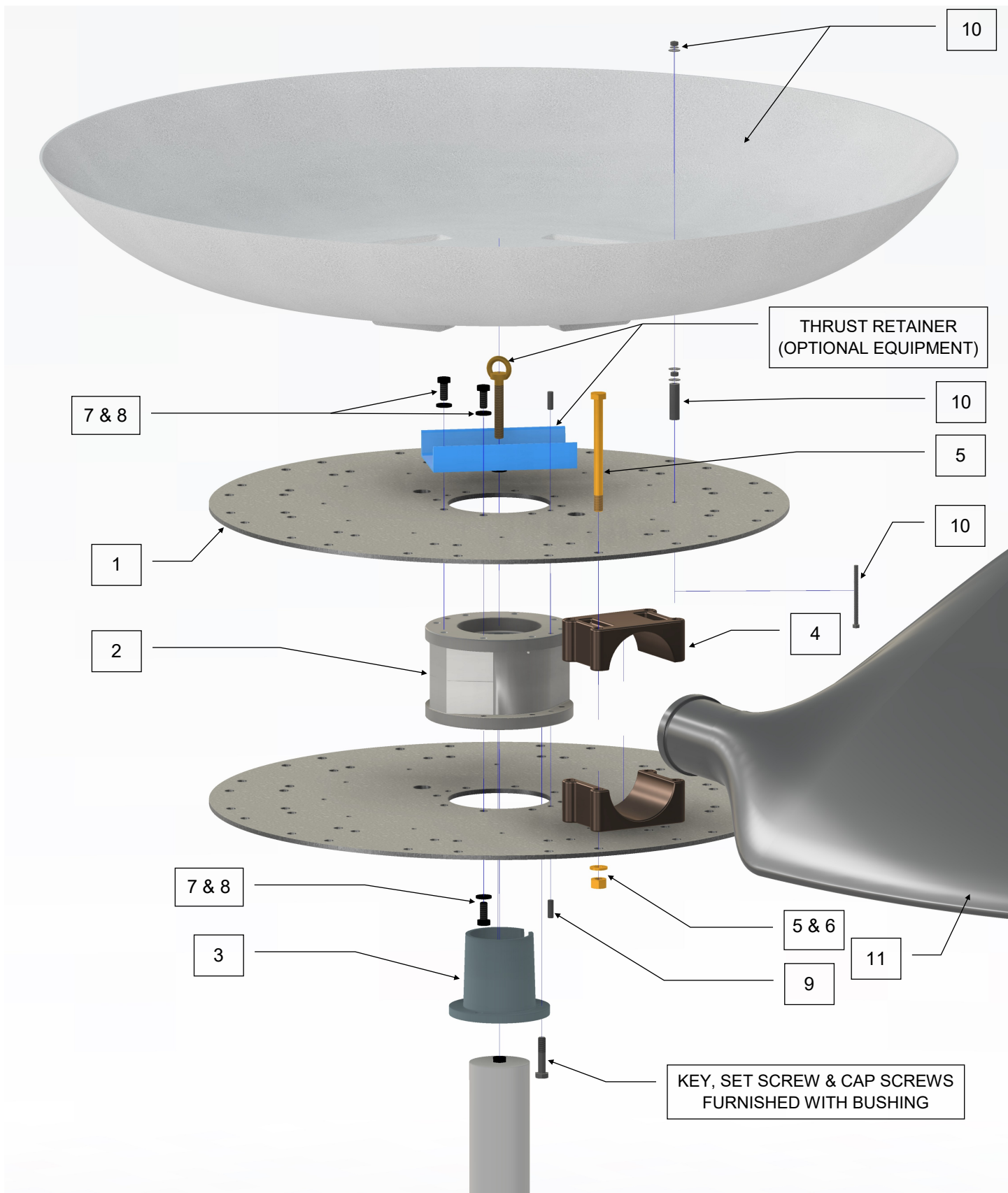

# **HUDSON**

## **Products Corporation**

9660 Grunwald Rd.

Beasley, Texas 77417-8600

Phone: 281-396-8100

Fax: 281-396-8388

1-800-634-9160 (24 Hours)

[EMAIL: HUDSONPRODUCTS@HUDSONPRODUCTS.COM](mailto:HUDSONPRODUCTS@HUDSONPRODUCTS.COM)

<http://WWW.HUDSONPRODUCTS.COM>

*Hudson, Auto-Variable, Combin-Aire, Exact-A-Pitch, Fin-Fan, Heatflo, Hy-Fin, Split-Flo, Solo Aire, Stac-Flo, Steamflo, Thermflo, Tuf-Edge, Tuf-Lite, Tuf-Lite II, Tuf-Lite III and Tuf-Lite IV* are registered trademarks of Hudson Products Corporation.

©2019 Hudson Products Corp. All Rights Reserved.