

Pneumatic Rolled Diaphragm Actuators Product Brief



The Challenge

When using old style unloader actuators customers commonly experience:

- Leakage of the process gas past the shaft and cover seals
- Problems with old OEM membrane diaphragms that can leak which prevents them from actuating the unloaders
- Problems with insufficient stroke length of old OEM membrane diaphragms that occur after the valves are reconditioned and the unloader finger travel height changes
- Inability of hand operated unloaders to be used with automated control systems

The Solution

Change to Custom designed actuators from CPI, part of the Howden Group, can be applied to existing cylinders to eliminate problems with old style diaphragm actuators. A key problem with old actuators is seal leakage which results in fugitive emissions into the atmosphere. New CPI actuators prevent this leakage with upgraded O-rings and shaft seals. As an extra precaution, a vent connection is supplied for the collection of any leaking process gas to the flare or disposal system.

The flat membranes commonly used in old OEM diaphragm actuators are based on old material technology which results in high stresses when the diaphragm is stretched when actuated. Over time this can lead to failure of the diaphragm which prevents the actuator from stroking the actuator shaft. This can be difficult to diagnose in the field and requires the compressor to be shut down for replacement. The rolled diaphragms are manufactured with a geometry that allows them to flex without creating high stresses.



A refinery customer experienced problems with gas leakage from their OEM old style diaphragm unloader actuators



CPI diaphragm unloader actuators with upgraded seals which reduced their emissions and improved their reliability

The Solution Cont.

Another advantage of these rolled diaphragm actuators is their extended stroke capability – often more than 3 times traditional membrane actuators. As the valves are reconditioned their seat thickness changes which often requires the adjustment of finger unloader travel on the suction valves. If this is not done properly, the fingers can either not unload the valves at all or they can hold the valves open all the time. Both of these conditions can only be identified with the compressor running which leads to time wasted during troubleshooting and the need for shutting the unit down for re-adjustment. The CPI actuator with extended stroke prevents the actuator stroke from causing adjustment problems.

FEATURES

- Designed to meet API 618 standards
- Extended stroke length (0.59 in / 15 mm) and adjustment (0.20 in / 5 mm)
- Sealing with O-rings and chevron packing up to pressures of 3,625 psi / 250 bar
- All parts in contact with the process gas are made of stainless steel for corrosion resistance
- Highly visible adjustable position indicator

CPI Unloader Actuators with upgraded seals reduce emissions, and when combined with a CPI valve upgrade, increases overall reliability

Most compressor cylinders are installed with valve unloaders that are used for start-up and capacity control. These unloaders come in a few main styles:

- Finger style unloaders which hold open the suction valve plates or rings
- Plug style unloaders which open a large orifice in the center of a suction valve or port
- Plug style unloaders which open a port in a clearance pocket



Example of rolled diaphragm style with finger unloader

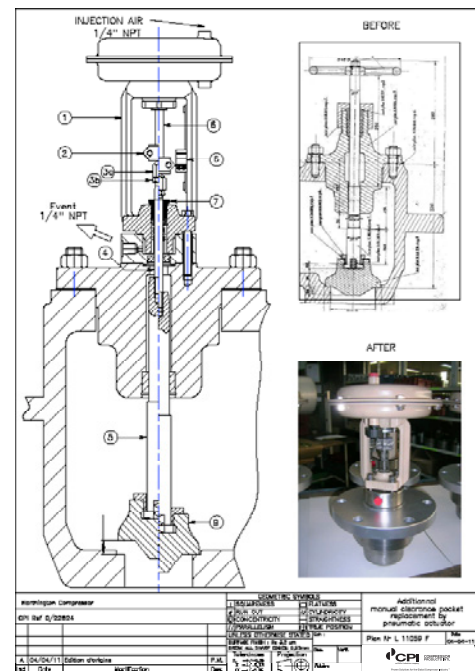

Example conversion of an old OEM manually operated clearance pocket:

- Eliminated gas leakage from the shaft
- Allowed the customer to automate their unloaders



© 2022 CPI. All rights reserved.