

Improve Air-Cooled Heat Exchanger Performance

STEVE BOES, P.E.
HUDSON PRODUCTS CORP.

Employ the maintenance practices outlined here to increase the cooling capacity of your air-cooled heat exchangers.

Air-cooled heat exchangers (ACHEs), sometimes called air coolers, are used in a variety of applications in refineries, petrochemical plants, gas treating plants, compressor stations, power plants, and other facilities. ACHEs are used for process cooling and/or condensing. There are thousands of these exchangers in use today, cooling and/or condensing everything from engine jacket water to process steam to highly viscous tar. Often, these processes are critical to the operation of the plant. An ACHE outage will trigger the plant to shut down or operate at reduced capacity, which may cause significant loss of revenue.

This article describes the operation of ACHEs and identifies critical components that could fail and reduce the cooling capacity. It also identifies maintenance practices and procedures that help increase heat exchange capability and reduce the probability of component failure.

Air-cooled heat exchanger basics

The operating principle of an ACHE is straightforward. Hot process fluid enters one end of the ACHE and flows through tubes, while ambient air flows over and between the tubes, which typically have externally finned surfaces (Figure 1). The process heat is transferred to the air, which cools the process fluid, and the heated air is discharged into the atmosphere. While this is a fundamentally simple concept, maintaining optimum ACHE performance takes diligence on the part of the end user.

Sizes of these units vary widely, from the very small (e.g., a car or truck radiator) to the very large (e.g., an A-frame vacuum steam condenser). Therefore, optimiza-

tion of existing ACHEs can take several approaches. For purposes of this article, optimization will be limited to those ACHEs typically found in refinery, chemical, or power plants built to American Petroleum Institute (API) Standard 661 (1).

There are two basic types of ACHEs found in petrochemical plants (Figure 2) (2):

- *forced draft* — the fan is located below the process bundle and air is forced through the tubes
- *induced draft* — the fan is located above the process bundle and air is pulled, or induced, through the tubes.

A typical ACHE consists of the following components (3):

- one or more bundles of heat-transfer surface consisting of finned or bare tubes connected by headers
- an air-moving device, such as an axial-flow fan, blower, or stack
- unless it is a natural draft application, a driver (usually an electric motor) and power transmission device (usually

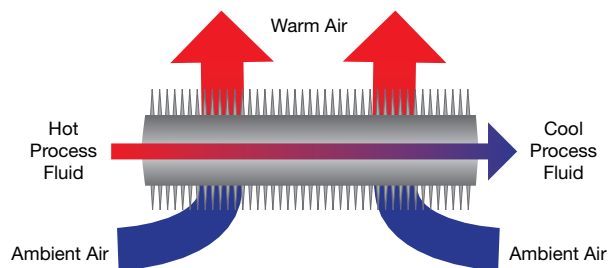

▲ **Figure 1.** In an air-cooled heat exchanger, hot process fluid flows through a finned tube. Ambient air passes over the finned tube, which cools the process fluid.

Back to Basics

belt or gear) to mechanically rotate the air-moving device

- a plenum between the bundle(s) and the air-moving device
- a support structure high enough to allow air to enter beneath the ACHE at a reasonable flowrate
- optional header and fan maintenance walkways with ladders to grade
- optional louvers for process outlet temperature control
- optional recirculation ducts and chambers for protection against freezing or solidification of high-pour-point fluids in cold weather
- optional variable-pitch fan hub or variable-frequency drive for temperature control and power savings.

Headers distribute fluid from the source piping to the finned tubes. For most applications, a plug box header design is used for the tube bundle (Figure 3, top). A cover plate header design can be used if the inside of header boxes must be accessed (Figure 3, bottom). Although it is the more expensive alternative, the cover plate design allows full access to the inside of the headers for inspection and cleaning. The cover plate design is usually limited, however, to a maximum design pressure of 350 psig.

A subset of the forced-draft design is the winterized unit (Figure 4). A forced-draft ACHE is outfitted with one or more methods (*e.g.*, air outlet louvers, fans equipped with variable frequency drives [VFDs], hot air recirculation systems) to control the temperature of the process fluid leaving the exchanger. This type of unit is typically found in colder

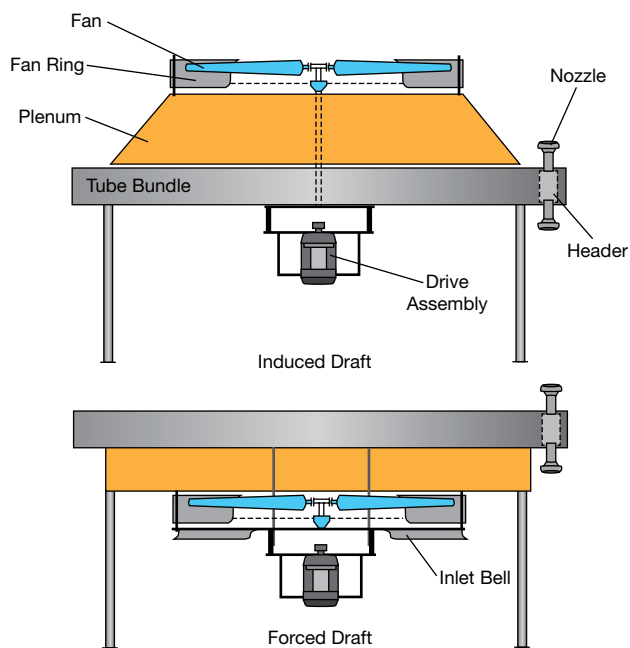

▲ **Figure 2.** An air-cooled heat exchanger typically has one or more tube bundles, a fan, a plenum between the bundles and the fan, and a support structure high enough to allow air to enter at a reasonable flowrate (2).

climates, but it is also used in hotter climates, such as the U.S. Gulf Coast, for process fluids with high viscosities and/or high pour points.

Routine maintenance

The reliability and thermal performance of any ACHE depends on how well its mechanical components are maintained. Figure 5 shows a typical ACHE mechanical drive layout. The components of ACHEs are fairly common; typically each bay has one, two, or three electric-motor-driven fans. Most have a speed reducer consisting of either a belt drive (*e.g.*, V-belt or cog belt) or right-angle gear drive.

A belt-drive system has four bearings that need to be lubricated — two motor bearings and two fan bearings for each fan. These are typically tubed to a common location somewhere on the drive assembly so they can be lubricated while the exchanger is running. Manufacturers usually recommend that you grease the bearings once a month if the coolers are in continuous operation. Right-angle gear drives should be lubricated according to the manufacturer's recommendations.

Check belt tension on a regular basis, usually every six weeks at a minimum for ACHEs that are in continuous service. Check belts for wear, and sprockets for tooth wear or cracking.

Inspect fans at least annually by following these procedures (4):

1. Visually inspect each blade and the hub, looking for cracking, rubbing, or excessive wear.

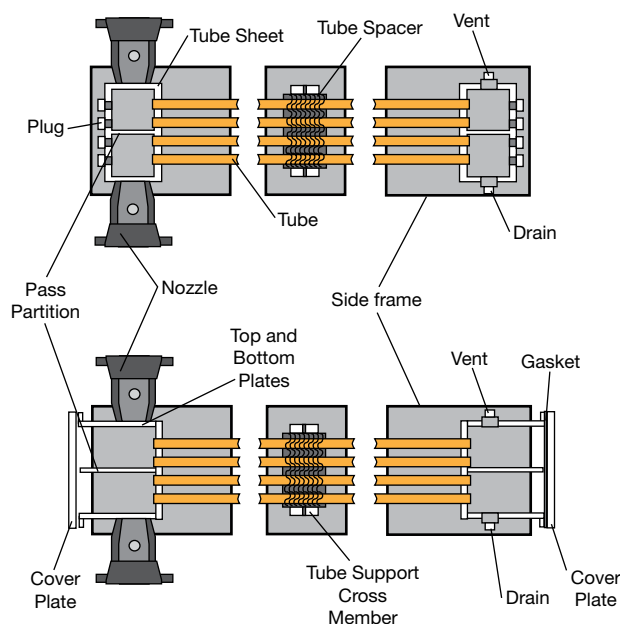

▲ **Figure 3.** Tube bundles may be constructed with plug headers (top) or cover plate headers (bottom).

2. Check all bolting hardware for proper torque, especially the blade-clamping bolts.
 3. Check blades for proper pitch as per the ACHE specification sheet. (Be sure to use the fan manufacturer's blade angle procedure, as this can vary from one manufacturer to another.)
 4. Check the blade tracking to be sure that all blades are riding in the same plane in the fan ring.
 5. Check blade tip clearances to be sure that they are all within recommended limits.
- Anti-rotation devices should be installed on fans to prevent belt damage when fans are restarted after being out of service. These also provide a safety measure for personnel performing maintenance.

Optimizing thermal performance

Before you can optimize your ACHE's performance, ask this fundamental question: What do you need the existing ACHE to do that it does not do now? Usually the answer to that question is to provide more cooling or to lower the process outlet temperature. Other goals may be to reduce power consumption or to improve process control. Whatever the answer, the approach is usually the same. For purposes of this discussion, we will assume that you need the ACHE to provide more cooling. Here are three steps to bring the exchanger to the desired condition:

Step 1 — Determine the original design performance of the ACHE. First, obtain a copy of the original manufacturer's specification sheet or datasheet for the unit(s). Typically, all ACHE original equipment manufacturers (OEMs) provide this document, as it is an overall description of the exchanger design. It contains information such as:

- basic process design data
- tubeside performance data
- airside performance data
- materials of construction information
- mechanical equipment information
- control information
- shipping information (e.g., size and weight).

Compare this document with the current process operating conditions. It is not unusual to find that the current



▲ **Figure 4.** A winterized forced-draft unit is outfitted with methods to control the process fluid temperature leaving the ACHE.

process conditions and associated ACHE duty requirements now exceed the as-built design by 5, 10, 20, or more percent. This gives you a target value — the amount of additional cooling you want or need versus what was originally purchased.

If the current duty requirement is equal to or less than the original design, then bringing the unit back to its original condition should resolve cooling issues. Step 2 gives suggestions for doing this.

If the current duty is significantly greater than the original design, there are some steps that can be taken to upgrade the ACHE. These are explored in Step 3.

Step 2 — Inspect the exchanger and make repairs to return it to its original condition. Most ACHEs, particularly in refineries and petrochemical plants, are located on a pipe rack at a high elevation. Thus, they typically get inspected only when there is a significant mechanical problem or during the summer months when ambient temperatures sometimes exceed the ACHE design air temperature and output is affected. Therefore, before you can initiate any improvements, you must perform a detailed visual inspection of the units. These are the major items to inspect (they are not in any particular order):

Tube Bundle

- Frame — Is it warped, distorted, or sagging?
- Tube supports and tube keepers — Are they warped, distorted, or sagging?
- Contoured fin supports or wiggle strips — Are they skewed or out of position?
- Air seals — Are the seals between units and under the headers missing or damaged? Can you feel air leakage?
- Headers — Are they warped or distorted? Are there leaks at the plugs or cover plate gaskets?

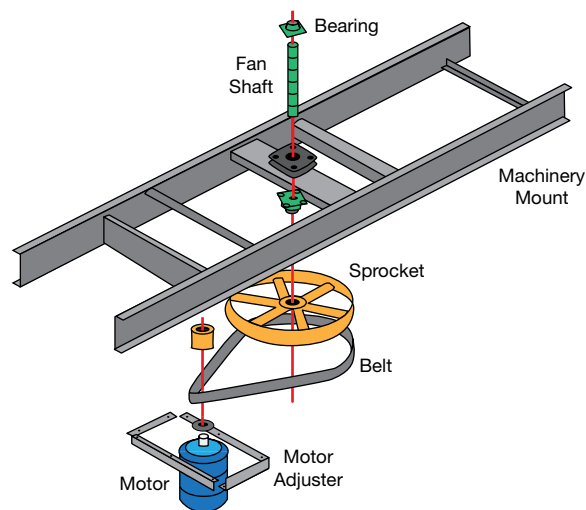

▲ **Figure 5.** A typical mechanical drive system for an ACHE fan consists of an electric motor with a speed reducer such as a belt drive.

Back to Basics

- Tubes — Are the tube bundles dirty (*e.g.*, from below can you see some daylight?) or fouled (Figure 6)? Are the tubes warped or distorted? Are the fins loose? Are the fins crushed (especially on the top rows)?

Fans

- Blade pitch — Do all the blades have the same pitch? Does the pitch match the datasheet?
- Blade tracking — Do the blades all track in the same plane?
- Tip clearance — Is there excessive clearance between the blade tips and the inside fan ring wall?
- Seal disc — If the fan has a seal disc, is it intact? Is it missing?
- Inlet bell — If the fan has an inlet bell, is it intact? Is it missing?
- Fan speed — Are the fans rotating at the speed specified on the datasheet?
- Vibration or pulsing — Are the fans vibrating (for example, because they are out of balance or operating near a resonate frequency)? Are they pulsing (*e.g.*, if they are in stall due to low speed or excessive pitch)?

Mechanical components

- Belts — Are they frayed or broken (Figure 7)? Are they tensioned properly?
- Sprockets — Are they cracked or worn?
- Alignment — Are the belts and sheaves properly aligned? If the fan has a cog belt drive, are the belts and sprockets meshing correctly?
- Motors — Does the motor current draw correspond to the design horsepower? If not, it may be an indication of improper pitch and/or dirty finned-tube bundle.

Controls

- Louvers — Do they fully open and close?
- Actuators — Are the louver actuators working properly? Do the louvers open and close when they should?
- Steam coil — Is the steam coil leaking or cracked?
- Variable-frequency drives — Are resonant frequencies blocked out?
- Auto-variable hub — Does the blade pitch vary with changes in supply air pressure? Do the blades feather out



▲ **Figure 6.** Finned tubes can become fouled. Make sure they are inspected for fouling during visual inspection of air-cooled heat exchangers.

to neutral or zero pitch when they are in operation? Is the supply air connected, operational, and set to the correct pressure?

Once this mechanical inspection is complete, steps should be taken as necessary to bring the ACHE back to the as-built condition. In some instances, simple bundle cleaning and fan adjustments, repairs, and/or modifications can bring the unit back to near-design performance.

It should be noted here that if the ACHE frames and supports are found to be warped or sagging, this is a strong indication of a potentially severe structural or thermal expansion problem. This should be addressed immediately before consideration of any bundle cleaning or mechanical upgrades.

Step 3 — Perform upgrades. If bringing the ACHE back to its original condition does not provide enough cooling duty, you still have several options at your disposal to improve and optimize your ACHE. The following sections describe typical steps that can be taken to optimize your ACHE, in order of increasing cost. Note that this is not an exhaustive list but covers those items common to all ACHEs.

Fans and mechanical components

In most applications, one of the quickest ways to get more cooling duty out of your ACHE is to increase airflow from the fans. Table 1 gives the expected increases in ACHE duty for a 10% increase in airflow. These numbers are not exact, but represent a good rule of thumb when increasing airflow from the fans. Increased airflow has the most effect



Examples of Pulley Misalignment

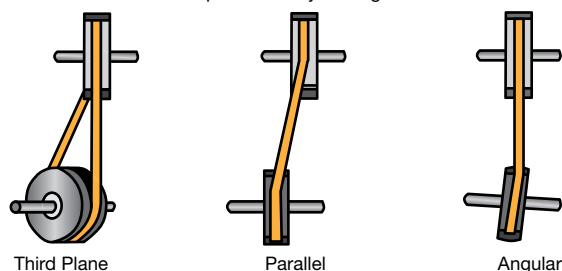

▲ **Figure 7.** Belt or pulley misalignment in the fan mechanical drive system can cause belts to fray and break.

on condenser duty, since the airside thermal resistance is the dominant factor in limiting heat transfer. Conversely, increased airflow has the least effect on viscous cooler duty because the tubeside thermal resistance dominates.

Therefore, depending on your service, increasing airflow via one of these methods may be a quick and nominally inexpensive way to reach your goal:

Increase the fan blade pitch. Increasing the fan blade pitch will increase airflow as long as the fan does not begin to stall and it has enough motor horsepower. If the fan is horsepower-limited, a motor upgrade will be required to achieve the needed airflow. Remember, for every 10% increase in airflow, there is a 21% increase in static pressure and a 33% increase in required horsepower.

Increase the fan speed. This will also increase airflow and prevent the fan from stalling, as long as the motor horsepower is high enough. If you are currently using V-belt drives, upgrading to cog belt drives will increase power transmission efficiencies as well as maintain design fan speeds. However, as the fan speed is increased, noise will increase as well, and cog belts emit slightly more noise near the drives (within 3 to 10 ft). If you have a gearbox, a new one with a different ratio will be necessary to increase speed.

Note that when you increase either fan pitch or speed, it is strongly recommended that the fan performance be checked against the fan manufacturer's rating software to ensure the existing fan will operate properly at the new setpoints.

Reset tip clearances. If not done as part of your mechanical assessment, correcting excessive tip clearance can, depending on the gap, significantly improve fan performance (by moving more air at the same horsepower) (5). Depending on the starting tip clearance, reducing the clearance can

ACHE Service	Thermal Duty Increase	
	Minimum	Maximum
Condensing	5%	7%
Liquid Cooling	3%	6%
Vapor Cooling	2%	5%
Viscous Cooling	0.5%	1%



▲ **Figure 8.** A tip seal retrofit can correct excessive tip clearance and improve fan performance.

increase airflow by 2–5% and reduce noise by 0.5 dBA. Some ACHE manufacturers allow for some adjustment in the fan rings or shrouds. If yours does not, tip seal kits are available to fill the excessive gaps to a preset distance (Figure 8). API-661 (1) recommends specific tip clearances as good design practice (Table 2).

Install inlet bells. Many ACHEs have entrances with sharp edges at the fan inlet. The addition of an inlet bell (usually made out of fiberglass or galvanized sheet steel) can increase total airflow by 2–3% and can reduce noise by as much as 1 dBA (Figure 9).

Install a fan seal disc. Some fan manufacturers supply a hub seal disc to prevent reverse flow at the center of the inboard section of the fan. This simple device is typically made of fiberglass or aluminum and normally covers 25–35% of the inner fan diameter (6). If measurements indicate a negative or downward airflow near the hub, a seal disc should be considered. The amount of airflow improvement will vary, but a 2–3% increase in airflow is not unusual.

Install high-efficiency fans. Some installations have low-efficiency straight-chord aluminum fan blades. Typically straight-chord blades have total efficiencies between 35% and 55%. Today, more modern fans (constructed of fiberglass and aluminum) are available that are more aerodynamic, with a tapered chord and an increasing pitch or twist from the blade tip to the hub. This tapered-twisted shape allows for a more uniform airflow off the fan blades, which produces significantly greater efficiency — normally 75% to 85% total efficiency. It is not uncommon to obtain 25% to 40% more airflow with high-efficiency fans at the same or slightly higher motor horsepower.

Fan Diameter	Radial Clearances	
	Minimum	Maximum
1 m (3 ft) to 3 m (9 ft)	6 mm (1/4 in.)	13 mm (1/2 in.)
3 m (9 ft) to 3.5 m (11 ft)	6 mm (1/4 in.)	16 mm (5/8 in.)
> 3.5 m (11 ft)	6 mm (1/4 in.)	19 mm (3/4 in.)



▲ **Figure 9.** An inlet bell can increase the total airflow in an air-cooled heat exchanger by 2–3%.

Back to Basics

Tube bundle

The heart of the ACHE is the tube bundle. A tube bundle is an assembly of tubes, headers, side frames, and tube supports. Typically, the airside tube surface has extended surface in the form of helical fins to compensate for the low heat-transfer rate of air at atmospheric conditions and low velocities (Figure 10). Because tubeside process pressures normally exceed 1 atm (15 psi), the optimal tube is usually round and can be of any metal suitable for the process fluid given its corrosivity, pressure, and temperature.

Fins can be formed from aluminum, copper, or steel, among other materials. The most prevalent fin material is aluminum because it has good thermal properties, it is lightweight, and it is easy to fabricate. Steel is typically used for high-temperature applications and copper for special severe-corrosion applications. There are three basic types of aluminum fins (Figure 11):

- *extruded* — the fins are extruded from the wall of an aluminum tube that is integrally bonded to the base tube
- *embedded* — a strip of aluminum is helically wrapped around the tube; the root is embedded into a precut groove and then mechanically locked to secure it
- *wrap-on (L-Base or L-Foot)* — a strip of aluminum that is footed at the root is helically wrapped on the tube.

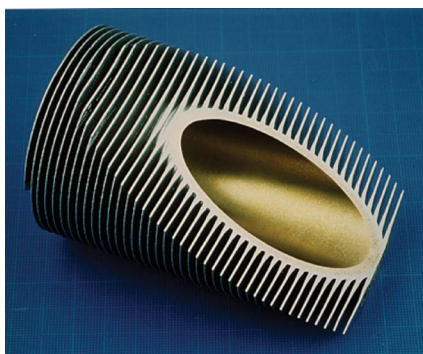

▲ **Figure 10.** Airside tube surfaces in an ACHE have fins to compensate for the low heat-transfer rate of air.

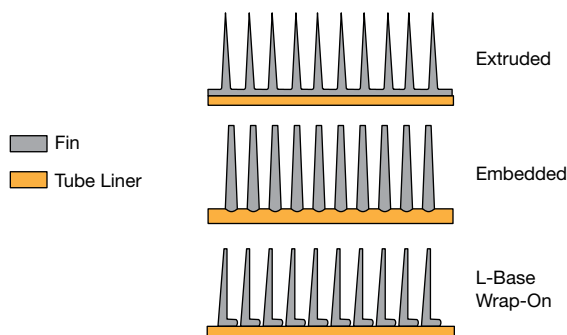

▲ **Figure 11.** The three basic types of aluminum fins are extruded, embedded, and wrap-on.

Serrations are sometimes cut into the fin tips or fin body to increase the airside heat-transfer rate. However, this improvement is accompanied by higher airside pressure drop and, depending on the physical location of the ACHE, by a greater propensity for fouling.

Clean the finned-tube bundle. One of the most effective ways to boost ACHE duty is to physically clean the tube bundle. Depending on the location of the exchanger, the top and bottom tube rows can become plugged with a myriad of organic and inorganic debris. This material does two things: it coats the fin surface and acts as an insulator, and it plugs the space between the fins, increasing airside static pressure and reducing airflow. Depending on the degree of fouling, duty increases of anywhere from 5% to as much as 50% (in extremely fouled bundles) can be achieved.

Methods for cleaning finned-tube bundles include high- or low-pressure water washes, foam cleansers, and dry media impingement. Dry media cleaning is typically the most effective and is least likely to damage the fins themselves (Figure 12). Dry cleaning also eliminates the need to dispose of the cleaning water and protect nearby components that could be damaged by the falling water.

Clean inside the tubes. Sometimes fouling is more severe inside the tubes. This is most common in process coolers handling viscous fluids or fluids that precipitate solids or waxes when the temperature falls below the minimum design point. Chemical flushes, as well as high-temperature and high-pressure steaming and pigging, are the most common methods of cleaning. Viscous-fluid coolers benefit more from cleaning the inside of the tubes than do condensers. As with airside cleaning, tubeside cleaning can improve ACHE duty anywhere from 5% to 50%.

Retube the bundle. If the condition of the finned tubes has significantly degraded due to overheating or excessive corrosion (Figure 13), retubing the bundle with an equivalent or higher-grade type of fin will be required.

Extruded fins typically have the highest ability to transfer heat, and their construction allows them to main-



▲ **Figure 12.** Dry cleaning is one of the most effective methods of cleaning the airside of tubes and is the least likely to damage the finned tubes.

tain that high level over many years. Embedded fins have heat-transfer coefficients comparable to those of extruded fins and are less expensive, but they degrade faster over time, especially in corrosive environments and when sprayed with water. Additionally, embedded-fin tubes require thicker-walled tubes (nominally one gauge heavier) to account for the mechanical fin groove. This will increase the tubeside pressure drop and may exceed existing process limits. Wrap-on fins are the least expensive, but also the most susceptible to damage caused by thermal upsets and airside corrosion.

Serrated fins normally provide a 15% to 33% higher airside heat-transfer rate than non-serrated fins. However, this comes at the expense of increased airside pressure drop and will sometimes require motor and drive upgrades to maintain current airflow rates. Overall, a 10% to 50% increase in ACHE duty can be achieved by retubing the bundle, depending on the level of finned tube deterioration.



▲ **Figure 13.** If the condition of tubes and fins is significantly degraded due to corrosion, the bundle will need to be retubed.

Table 3. Certain ACHE upgrades will afford greater improvements, but may cost more.		
Upgrade	Improvement	Cost
Adjust Blade Pitch	More airflow	Low
Increase Fan Speed	More airflow	Low
Limit Tip Clearance	2–5% More airflow, –0.5 dBA noise	Low
Install Inlet Bell	2–3% More airflow, –1 dBA noise	Low
Install Seal Disc	2–3% More airflow	Low
Align Belts and Drives	3–4% More drive efficiency	Medium
Install High-Efficiency Fans	25–40% More airflow	Medium
Clean Fins	5–50% More duty	Medium
Clean Tubes	5–50% More duty	Medium
Retube Bundle	10–50% More duty	High
Replace Bundle	10–50% More duty	High

Replace the bundle. Severe finned-tube corrosion is sometimes an indication that the headers and bundle frame may have reached the end of their useful life. Schedule is also a factor — given today’s compressed turnaround schedules, it is sometimes more expedient to replace the entire bundle with a new one. The new tube bundles can be fabricated in advance of the turnaround so that the existing bundles can be removed and the new bundles immediately installed. This also allows the user to add tube rows, modify tube pitch, or upgrade fin type to increase the amount of duty without increasing footprint. As with retubing, 10% to 50% increases in ACHE duty can be achieved.

Closing thoughts

You can improve reliability and optimize the performance of your ACHE by following these steps:

1. Perform routine maintenance.
2. Optimize performance.
 - a. Determine original design performance.
 - b. Repair back to original condition.
 - c. Perform upgrades.

The relative costs of these upgrades are summarized in Table 3. These steps can take several avenues depending on the condition of the ACHE and the performance improvement desired. Although changing one or two things will normally improve unit performance, a total system approach to optimization — not just simply a retubing, a bundle cleaning, or a fan retrofit by itself — usually provides the best overall value for your capital upgrade dollars. CEP

LITERATURE CITED

1. **American Petroleum Institute**, “Air-Cooled Heat Exchangers for General Refinery Service,” 7th Ed., Standard 661, API, Washington, DC (July 2013).
2. **Hudson Products Corp.**, “The Basics of Air-Cooled Heat Exchangers,” (Sept. 2000). [\[need author or link for this paper\]](#)
3. **Giammaruti, R.**, “Performance Improvement to Existing Air-Cooled Heat Exchangers,” Cooling Technology Institute (Feb. 2004).
4. **Hudson Products Corp.**, “Fin-Fan Maintenance,” (Jan. 2007). [\[need author or link for this paper\]](#)
5. **American Society of Mechanical Engineers**, “Performance Test Code 30 — Air Cooled Heat Exchangers,” PTC 30, ASME, New York, NY (1991).
6. **Monroe, R. C.**, “Minimizing Fan Energy Costs,” *Chemical Engineering*, p. 141 (May 27, 1985).

STEVE BOES, P.E., is the Director of Sales and Marketing for Hudson Products Corp. He holds a BS in mechanical engineering from the Ohio State Univ. and is a Licensed Professional Engineer in the state of Oklahoma. He has over 18 years of experience in the design and manufacture of air-cooled heat exchangers. He is a member of the American Society of Mechanical Engineers (ASME).