



Cooler By Design.®

Dual Blower Fan Air Disposal (FAD) Vaporizer

Operation and Maintenance Manual



Designed and Built by:

Chart Distribution and Storage Group

407 Seventh Street NW,

New Prague, MN 56071

(952) 758-4484

Contents

Important Safety Note	v
Important Note	v
Revision Log	v
System Overview	1
General Description	1
Equipment Specifications	1
Major Components	2
Danger, Warning and Caution Symbols	3
Service	4
Design Modification	4
Operator Qualifications	4
Manufacturer Liability Statement	4
About this Manual	4
Safety	5
General	5
Safety Summary	5
General First Aid	6
Asphyxiation	6
Skin	6
Eyes	6
Ingestion	6
General Oxygen Safety	7
Oxygen Enriched Atmospheres	7
General LN ₂ and LAR Safety	8
Properties and Hazards of LN ₂ and LAR	8
System Safety Components	9
Installation	10
Site Preparation	10
Site Protection	10
Installation Considerations	10
Receiving	10
Handling Instructions	10
Inspection	10
Receiving Checkpoints	11
Site Considerations	11
Mechanical Assembly	11
Electrical Assembly	14
Line Power	14
Signal Wires	15
Remote Connection	16
Formatting the USB drive	16

Creating the Configuration File	17
EXAMPLE – Connecting to a (Chart) LinkManager Account	17
Configuring the Secomea SiteManager	19
Setting up Remote Access Through GateManager	20
System Controls	23
Control Panel	23
HMI Screens	24
Home Screen	24
Settings Screen	26
Setup Screen	27
Alarms Screen	28
Operation	29
Before You Run the Vaporizer.	29
Vaporizer Operation.	29
To Run the Blower Motors Independent of the System Controls.	33
Maintenance and Adjustments	34
Blower Motor Controller Blink Codes.	34
Header Settings Screen Functions	34
To Log into Access Settings	34
To Manually Control the Fans and Valves.	36
To Change a Header Setting.	37
To Reset the Header Settings to the Factory Default Values	38
To Set or Change Factory Defaults	38
Appendix A – P&ID	A1
Appendix B – Component I/O Manuals	B1
Appendix C – Control Panel Electrical Drawings	C1
Appendix D – Recommended Spare Parts	D7
Appendix E – PLC IP Configuration	E1
192.168.1.1	E1
255.255.255.0.	E1



Important Safety Note

Consult and follow the owner/operator's company policies for working in a cryogenic liquid or gaseous environment.

Any and all Operators, Maintenance Personnel or anyone else involved with using or working on these units must be fully aware of and fully trained to deal with the hazards of cryogenic liquids and gases. If you are not so aware and trained, DO NOT use or work on this equipment.

Please refer to the specific cautions listed in the **Safety** section of this manual.



Important Note

Please make sure to read this entire manual before working on this equipment.

Revision Log

Revision Level	Date	Description
A	10/27/2021	Initial publication
B	07/13/2023	Content Changes
C	05/13/2024	Updated Software & Photos
D	03/03/2025	Added Remote Connection Instructions, Updated Appendices & Photos

System Overview

General Description

The Chart® Dual Blower Fan Air Disposal (FAD) Vaporizer is designed to vaporize and dispose of cryogenic liquid and gas into the atmosphere. The two Air Blowers direct air into baffles in the bottom of the aluminum Vaporizer Duct which direct the airflow upward toward the top of the Vaporizer Duct. When cryogenic liquid or gas is introduced into the Vaporizer Duct, the liquid is vaporized and the vapor is discharged through the top. The unit has a maximum cryogen capacity of 60,000 pounds per hour.

Cryogen Distribution Rings, connected to individual Spools, introduce the cryogenic liquid/gas into the Vaporizer Duct. The Cryogen Distribution Rings can be programmed for argon, nitrogen, or oxygen.

Thermocouples are installed on the tip of the baffles and in the drip edge at the bottom of the baffles. The thermocouples detect any liquid that might get past the blowers and fall to the bottom of the Vaporizer Duct. The thermocouples are a safety measure used as a fail-safe intended to notify the Operator of abnormal Vaporizer function. The thermocouples should not drop below ambient temperature if the Vaporizer is below maximum flow. The frame cross-members have pathways to drain off any liquid that may collect in the bottom of the unit.

The Human-machine Interface (HMI) on the Control Cabinet displays the screens from which the Operator runs the unit and views the status of the machine components. The HMI screens can also be accessed via the unit's remote connectivity capability and the customer's network configuration. An Ethernet connection is provided at the bottom of the Control Cabinet.

Equipment Specifications

Dimensions	Overall Length: 262 inches [665.5 cm]	
	Overall Width: 94 - 1/2 inches [240 cm]	
	Overall Height: 243-11/16 inches [619 cm]	
	Vaporizer Duct Outside Diameter with Flange: 56-1/4 inches [142.9 cm]	
	Vaporizer Duct Outside Diameter: 50 - 1/4 inches [127.6 cm]	
	Estimated Shipping Weights	Shipping Weight: 9200 pounds [4,173 kg]
Dry Weight: 9085 pounds [4,121 kg]		
Design Specifications	Design Pressure: 150 psig (10.3 bar)	
	Test Pressure: None (Drilled Manifold)	
	Design Temperature: -320° to 150°F [-195.6° to 66°C]	
Sound Pressure Level	94 dB at 3ft from unit	
Electrical Requirements	Blower Motors: 480 VAC, three-phase, 60hp	
	Line Power Requirements: 200-amp service (two Blower Motors)	
	Power for Valve Actuators: 120 VAC	
	Control Power: 24 VDC	

Major Components

- The Control Cabinet houses the electrical components and controls including the **Main Electrical Disconnect**, **HMI**, **EMERGENCY STOP** switch and **Blower Override** key switches.

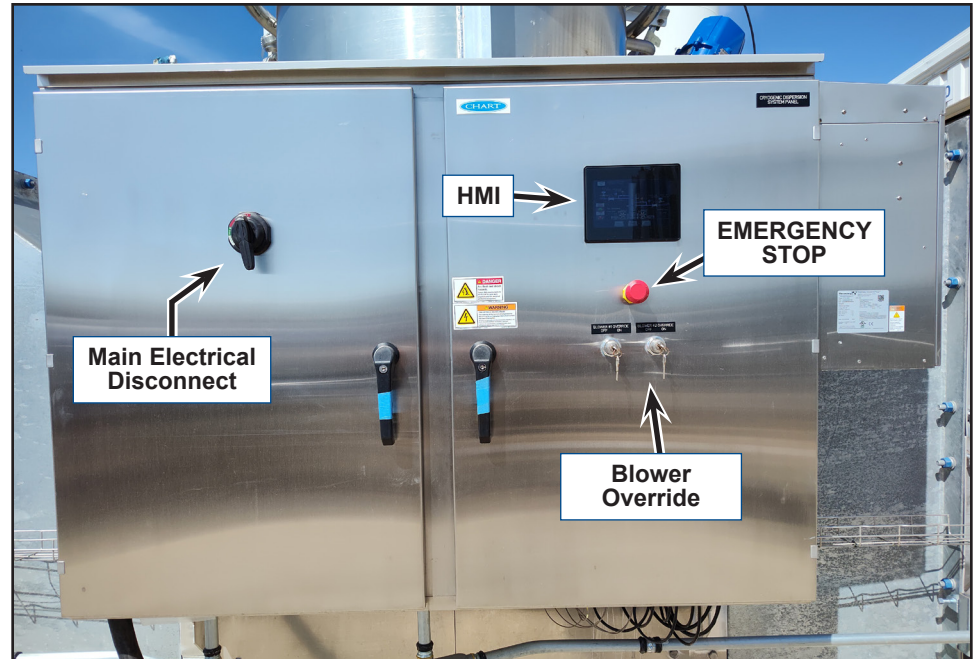

- The two fans are powered by 60 HP, 108 amp **Electric Motors**. Baffles at the bottom of the **Vaporizer Duct** direct the airflow from the **Fans** upward through the top of the **Vaporizer Duct**.

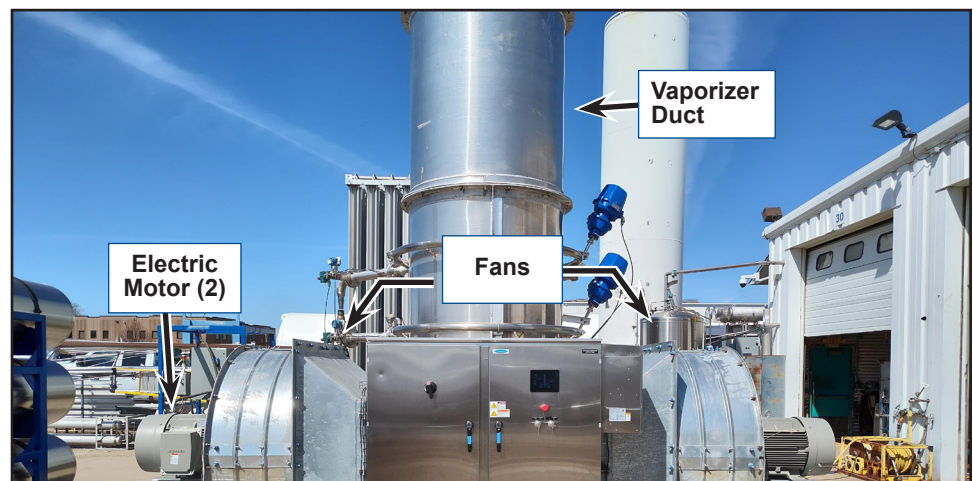

- The **Cryogen Distribution Rings** introduce the cryogenic liquid/gas into the Vaporizer Duct.
 - Each Cryogen Distribution Ring can be programmed for use of a specified cryogen.
 - Each Cryogen Distribution Ring contains 6 Nozzles to evenly disperse the cryogens into the Vaporizer Duct
- **Electric Actuators** control the **Valves** which operate as follows:
 - When gas is detected in the **Spool**, the corresponding **Valve** will open to clear the line of gas quickly.
 - When liquid is detected in the **Spool**, the **Valve** will close to direct the liquid to the corresponding **Cryogen Distribution Ring**.

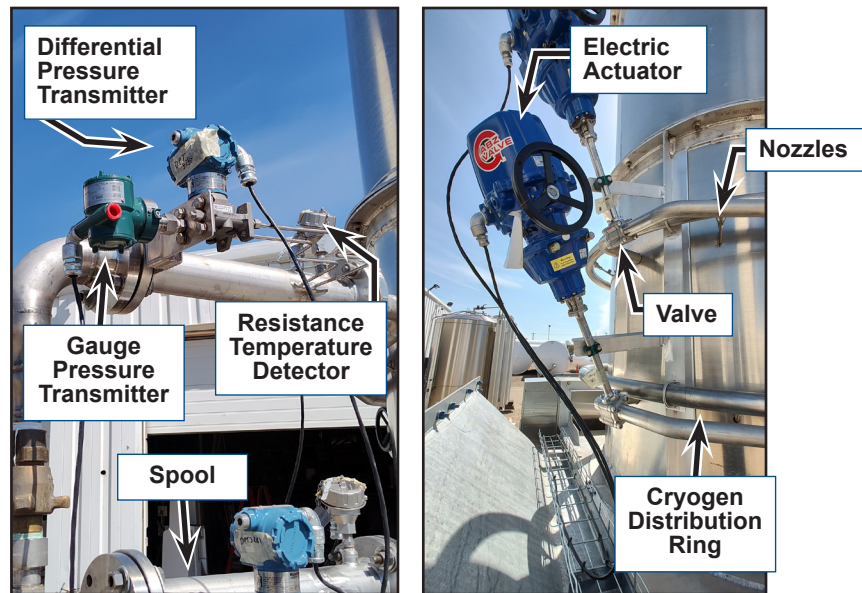

- The **Spools** have 3" ANSI Class 150 stainless steel flanges to connect with the customer's supply piping.
- Flow metering elements are installed internally in the **Spools** which provide inputs to the **Pressure Transmitters**. The system software allows the **Pressure Transmitters** to act as flow meters. The flow rates are automatically calibrated for the material phase (liquid or gas) passing through the **Spools**.
- **Resistance Temperature Detectors** (RTDs) monitor the temperature of the material flowing through the **Spools** and provide inputs to the control system.

Danger, Warning and Caution Symbols

This manual uses the symbols below to signal potentially dangerous conditions. Read this information carefully and take the necessary steps to protect Personnel and property.



Danger! Is used to warn of immediate hazards that will cause severe personal injury or death.



Warning! Is used to call attention to a situation that could cause severe personal injury.



Caution! Is used to call attention to a situation that could cause minor personal injury, or damage to the equipment or other property.

Service

The Chart® Dual Blower Fan Air Disposal Vaporizer has been designed for years of safe and dependable operation. In the event service is required, contact Chart.

Design Modification

- DO NOT use this equipment in a manner inconsistent with the instructions outlined in this manual.
- DO NOT alter the equipment design or perform any service inconsistent with the instructions outlined in this manual without the prior written approval of Chart Inc.
- ALWAYS use replacement parts authorized by Chart Inc. when replacing parts and components.

Operator Qualifications

Chart® equipment is designed for safe and simple operation. Operators are expected to be knowledgeable regarding the nature of the cryogenic liquids and gases with which they are working, as well as all applicable safety requirements. This manual contains several sections dealing with installation and maintenance procedures. To fully understand these procedures, we recommend that Operators and Maintenance Personnel first become familiar with the unit controls and indicators.

Manufacturer Liability Statement

The manufacturer believes the information presented in this manual to be accurate and up to date, and assumes no liability concerning use of information contained herein by any party. The information contained herein is not a recommendation to violate federal, provincial, state, or municipal laws or regulations.

About this Manual



This manual contains information regarding the safe operation of the Dual Blower Fan Air Disposal (FAD) Vaporizers. It should be read and understood thoroughly by anyone who operates this equipment. This manual is intended to provide the cryogenic service employee with information necessary to install and operate the FAD Vaporizers.

Safety

General

All Operators should have a full and complete understanding of the contents of this manual before operating the equipment described. This manual is intended to describe the operation of the equipment and not intended to supersede any site-specific standards.

As with any cryogenic system, it should be observed that any non-insulated piping can get extremely cold and should not be touched by exposed skin. If the system requires maintenance, it should be shut down and allowed to warm up.



Warning! *The sound pressure level at the Control Cabinet during operation has been measured at 94 dB. Always make sure to use approved hearing protection when operating or working around this equipment.*



Warning! *Operating the unit during extreme wind conditions may damage the systems fans. Do NOT operate in winds excess of 60 mph.*



Warning! *Operating the unit during heavy rain conditions may cause ice dams and “snow out” conditions. Monitor the vaporizer duct during rain conditions.*

Safety Summary

Strict compliance with approved safety and handling practices is necessary when using a cryogenic system. We recommend that all our customers re-emphasize safety and safe handling practices to all their employees and customers.

While every possible safety feature has been designed into the unit and safe operations are anticipated, it is essential that the user of cryogenic equipment carefully read and fully understand all **Danger**, **Warning** and **Caution** notes listed in this **Safety** manual section and throughout this manual.

External valves, fittings and piping can become extremely cold and can cause painful burns to personnel unless they are adequately protected. Personnel must wear protective gloves and eye protection whenever removing parts or loosening fittings. Failure to do so can result in personal injury due to the extreme cold. Protect your eyes and cover skin whenever the possibility of contact with liquid, cold pipes and equipment, or cold gas exists. Safety goggles or a face shield should be worn if liquid ejection or splashing could occur, or if cold gas could be emitted forcefully from the equipment. Clean, insulated gloves that can be removed easily, and long sleeves are recommended for arm protection. Cuff-less trousers should be worn over the shoes to shed spilled liquid.



Warning! *Accidental contact of liquid gases with skin or eyes can cause a freezing injury similar to a burn.*



Warning! NEVER use components (valves, gauges, fittings, etc.) or piping as steps or footholds. Always use appropriate equipment to access components for maintenance or repair.

General First Aid

Asphyxiation

LN₂ and LAR are asphyxiators capable of displacing air and creating an oxygen-deficient atmosphere. If someone is exposed to an LN₂ or LAR induced oxygen-deficient atmosphere:

- Remove the person to an area where there is fresh air.
- Give artificial respiration if the person is not breathing.
- Administer oxygen to any person having difficulty breathing.
- Seek immediate medical attention.

Skin

Contact of skin with cryogenic gasses or liquids can cause freeze burns and frostbite. If skin is exposed to cryogenic gas or liquid:

- Remove all contaminated clothing.
- Flush the contaminated area with cool or lukewarm water. **Do Not Use Hot Water.**
- Seek immediate medical attention if blistering, freezing or frostbite occurs.

Eyes

Contact of eyes with cryogenic gas or liquid can cause freeze burns, frostbite and permanent eye damage. If there is a cryogenic gas or liquid incurred eye injury:

- Soak eyes with cool or lukewarm water. **Do Not Use Hot Water.**
- Open eyelids to allow the gas or liquid to evaporate.
- Protect eyes with a clean cloth or handkerchief if eyes are sensitive to light.
- Do not apply ointment or any other medication to the eyes unless directed to do so by authorized medical personnel.
- Seek immediate medical attention.

Ingestion

Although ingestion is highly unlikely, cryogenic gas or liquid can cause freeze burns or frostbite to exposed mucous membranes. If cryogenic gas or liquid is ingested:

- Do not induce vomiting. This could allow the gas or liquid to be inhaled into the lungs, creating additional injuries.

- Rinse the mouth with water.
- Administer one or two glasses of water or milk. Never administer liquids to an unconscious person.
- Seek immediate medical attention.

General Oxygen Safety

Oxygen, Refrigerated Liquid	
DOT ID Number	UN 1073
Hazard Class	2.2
Label	Oxygen, Refrigerated Liquid



Danger! *In oxygen-enriched atmospheres flammable items burn vigorously and could explode.*



Warning! *Do not permit smoking or open flame in any area where oxygen is stored, handled or used. Failure to comply with this warning can result in serious personal injury.*

Excess accumulation of oxygen creates an oxygen-enriched atmosphere (defined by the Compressed Gas Association as an oxygen concentration above 23%). Certain items considered noncombustible in air may burn rapidly in such an environment. Keep all organic materials and other flammable substances away from possible contact with oxygen; particularly oil, grease, kerosene, cloth, wood, paint, tar, coal, and dust and dirt that may contain oil or grease.



Danger! *If clothing should be splashed with liquid oxygen it will become highly flammable and easily ignited while concentrated oxygen remains. Such clothing must be aired out immediately, removing the clothing if possible, and should not be considered safe for at least 30 minutes.*



Warning! *When replacing components that are to be exposed to oxygen, use only replacement parts that are compatible with liquid oxygen and have been cleaned for oxygen use.*

Oxygen Enriched Atmospheres

An oxygen-enriched atmosphere occurs whenever the normal oxygen content of air is allowed to rise above 23%. While oxygen is nonflammable, ignition of combustible materials can occur more readily in an oxygen-rich atmosphere than in air, and combustion proceeds at a faster rate although no more heat is released.

It is important to locate an oxygen system in a well-ventilated area since oxygen-rich atmospheres can collect temporarily in confined areas during the functioning of a safety relief device, or from system leakage.

Oxygen system components, including but not limited to, containers, valves, valve seats, lubricants,

fittings, gaskets and interconnecting equipment, including hoses, must have adequate compatibility with oxygen under the conditions of temperature and pressure to which the components may be exposed in the containment and use of oxygen. Easily-ignitable materials should be avoided unless they are parts of equipment or systems that are approved, listed or proven suitable by tests or past experience.

Compatibility involves both combustibility and ease of ignition. Materials that burn in air may burn violently in pure oxygen at normal pressure, and explosively in pressurized oxygen. In addition, many materials that do not burn in air may do so in pure oxygen, particularly when under pressure. Metals for containers and piping must be carefully selected, depending on service conditions. The various steels are acceptable for many applications, but some service conditions may call for other materials (usually copper or its alloy) because of their greater resistance to ignition and lower rate of combustion.

Similarly, materials that can be ignited in air have lower ignition energies in oxygen. Many such materials may be ignited by friction at a valve seat or stem packing, or by adiabatic compression produced when oxygen at high pressure is rapidly introduced into a system initially at low pressure.

General LN₂ and LAR Safety

Nitrogen, Refrigerated Liquid	
DOT ID Number	UN 1977
Hazard Class	2.2
Label	Nitrogen, Refrigerated Liquid

Argon, Refrigerated Liquid	
DOT ID Number	UN 1951
Hazard Class	2.2
UN Shipping Name	Argon, Refrigerated Liquid

Properties and Hazards of LN₂ and LAR

Although LN₂ and LAR are non-toxic, they can asphyxiate those working in confined spaces where there has been a release. Nitrogen and argon gas cannot be detected by the human senses since they are colorless, odorless and tasteless. Without adequate ventilation, nitrogen and argon will displace oxygen, creating an oxygen-deficient atmosphere incapable of supporting human life. The normal oxygen content of air is approximately 21%. Depletion of oxygen content in air by displacement is a potential hazard. All personnel must exercise caution when working in confined spaces and areas where there is a risk of a nitrogen or argon release.

Refer to the following table for symptoms associated with percent (%) values of oxygen deficiency.

% (Percent) Oxygen Content	Symptoms
16-21	No signs or symptoms
14-16	Increase in rate and depth of breathing

12-14	Deep respiration, quickened pulse, loss of coordination
10-12	Irregular breathing, poor judgment, blue lips
8-10	Nausea, loss of consciousness, ashen face
6-8	Loss of consciousness, death (if not promptly moved to safety)
4-6	Coma, convulsions, respiration ceases, death

As oxygen content falls below 12%, individuals may become mentally incapable of diagnosing the situation. The onset of symptoms such as sleepiness, fatigue, weariness, loss of coordination, errors in judgment and confusion may be masked by a state of “euphoria,” leaving victims with a false sense of security. Unconsciousness can be immediate with no warning as the oxygen content falls below 10%. Either rapid or gradual depleting of oxygen can lead to the onset of the above symptoms.



Warning! *The symptoms listed above may occur much more quickly to persons with coronary, pulmonary, or circulatory problems. Persons with such problems must exercise extreme caution when working in confined spaces or areas where there is a potential for an oxygen-deficient atmosphere to occur.*

System Safety Components

- Motor controller fault indicator/shutdown – the **Motor Icon** on the blower will change state to red and the fan blade indicator will display FLT (fault) to indicate a fault in the Allen-Bradley® motor controller.
 1. Check the front of the unit to get the definitions of the LED fault codes.
 2. Press the **PUSH TO RESET** button to reset the fault
- Any safety or functionality concerns will appear on the alarms screen as well.

The screenshot displays the control interface for the Dispersion System_R007. The top section shows a process diagram with various sensors and actuators. A red 'Motor Icon (2)' is highlighted, indicating a fault. The interface includes a 'System On' status, a 'System Enabled' indicator, and an 'Estop' button. The bottom section shows an 'Alarms' screen with a table for alarm details and buttons for 'Check/Uncheck All', 'Ack', 'Alarms', and 'Home'.

Select	Name	State	Time	Description

Installation

Site Preparation

Site preparation considerations include selecting the correct foundation. However, before the foundation is laid it may be necessary to clear the site of all organic material and topsoil. Concrete pads are the most common foundations on which cryogenic equipment is installed. They provide a highly-stable, permanent location for the unit, as well as any other on-site support equipment that may be required. The construction of a firm base or foundation for the concrete pad is also important. A bed consisting of gravel or crushed stone may be required on which the foundation will rest.

Consultation with a local qualified engineer is suggested to recommend a pad design that meets local and state requirements for soil and climatic conditions, as well as seismic load requirements.

A local qualified engineer should design a mounting bolt hole pattern for the system, and should size the bolts to attach the system to the pad.

Site Protection

In many situations cryogenic equipment is vulnerable to damage. This may be due to tampering by unauthorized personnel, other equipment moving in the area, or a combination of these. Depending on the exposure, protection should be provided by either a fence or pylons.

Installation Considerations

Installation of the Dual Blower Fan Air Disposal Vaporizer should be supervised by personnel familiar with its construction and intended use.

Following installation, all piping and connection points should be tested at maximum operating pressure to check for leaks.

Receiving

Handling Instructions

Installing the equipment on-site requires a lift crane.



Note: If the pad is not completed when the equipment arrives, arrangements should be made to have the unit taken from the truck and stored in a protected area.

Inspection

A receiving inspection is one of the most important operations in the life of the equipment, and should be done thoroughly and conscientiously. Report any indications of damage immediately to the freight company and Chart.

Receiving Checkpoints

1. Check the braces, skids, wooden chocks and other supports shipped with the equipment. Damage or deformation would indicate the possibility of mishandling during shipment.
2. Examine the welded joints, Distribution Rings and Nozzles for cracks or breaks.
3. Check all fasteners for any that might have loosened during shipment. Tighten as required.

Site Considerations

If the equipment is to be installed at the user's site, consider the following prior to installation.

- Prime considerations in choosing a site for the equipment are the location's soil stability, accessibility for servicing, proximity to the vapor/liquid dispensing point, and clearance for the vent stack to properly dispel the vaporized liquid without overhead limitations or damage to surrounding structures or power lines.
- Firm soil conditions are desirable to protect against settling of the equipment and possible equipment damage. The foundation site must also be located to ensure that drainage is away from the foundation.
- The site selected should ensure that the equipment will not be beneath or exposed by the failure of electric power lines, flammable or combustible liquid lines, or flammable gas lines.

Mechanical Assembly

1. Connect the crane to the **Lifting Lugs** on the top of the **Vaporizer Duct**. The use of a spreader bar is recommended.

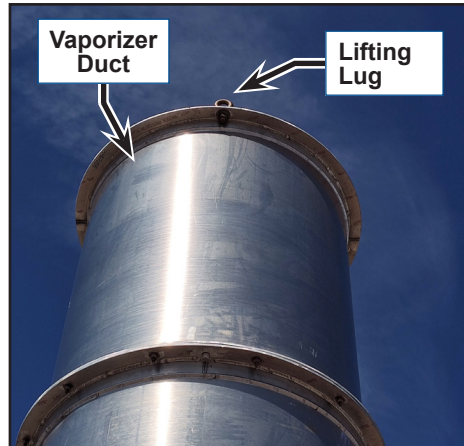

Warning! Do not begin assembly without completing Site Preparations

2. Lift and position the **Upper Section** of the **Vaporizer Duct** over the **Lower Section** of the **Vaporizer Duct** as shown.

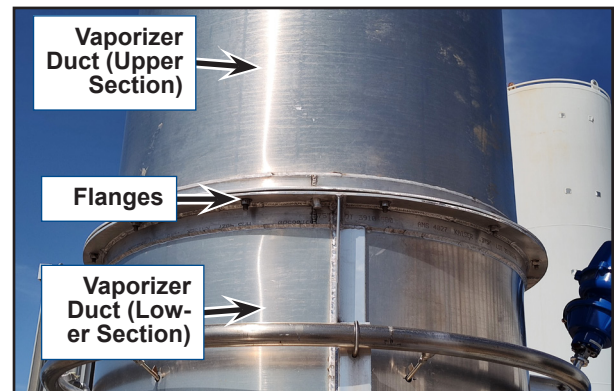

3. Align the **Witness Marks** on the **Upper and Lower Flanges** so the **Pin** in the **Upper Flange** aligns with the hole in the **Lower Flange**.
4. Fasten the Upper Section of the Vaporizer Duct to the Lower Section of the Vaporizer Duct.

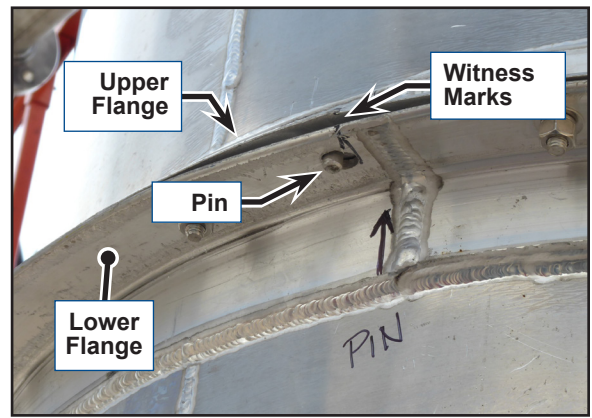

5. Fasten the **Spools**, with attached Resistance Temperature Detector (**RTD**) and **Pressure Transmitters**, to the **Flange** on the corresponding **Distribution Ring**. Spray flanges with isopropyl alcohol prior to fastening to assure a clean mating. Assure flow direction on spool points towards the vaporizer duct and not towards the supply. Note that the Spools are labeled L101, L201 and L301 per the P&ID (shown in [Appendix A](#).)

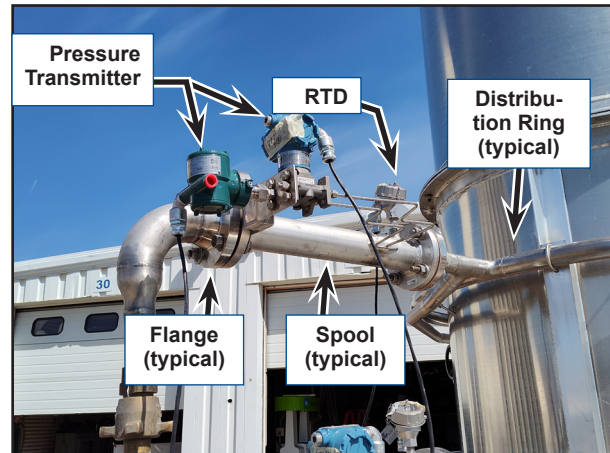
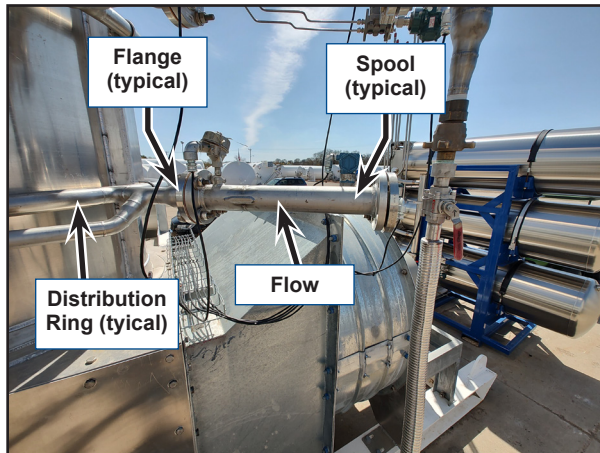

6. Fasten the **Valve Actuators** onto the corresponding **Valves Stems**. When installing the **Valve Actuators**, align the black **Witness Mark** on the valve stem with the **Valve Actuator** as shown.

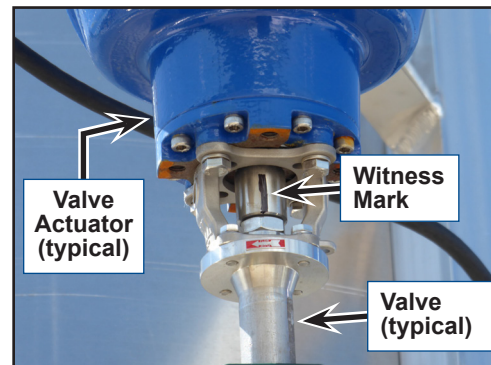
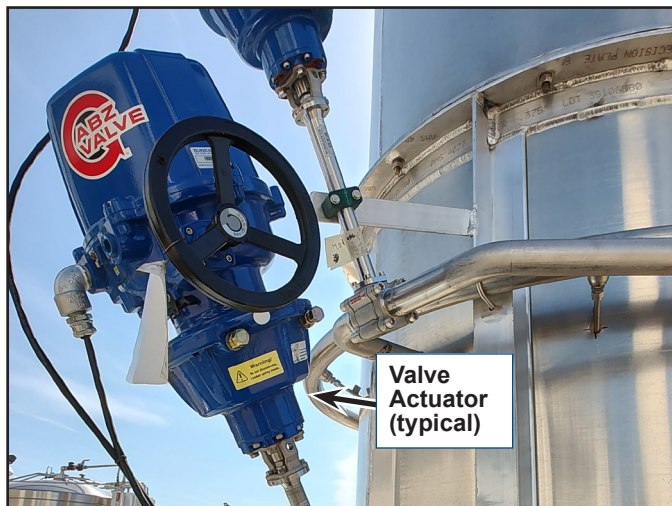

7. Fasten the **Valve Actuators** to the corresponding **Support Brackets** on the **Vaporizer Duct** using four M6X1 bolts.

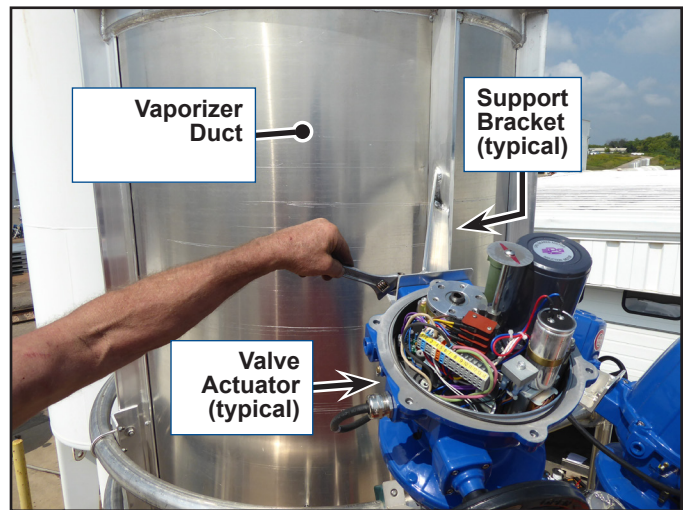

8. Install the vapor/liquid **Supply Piping** to the **Flange** on the corresponding **Spool**. Once again spray flanges with isopropyl alcohol.

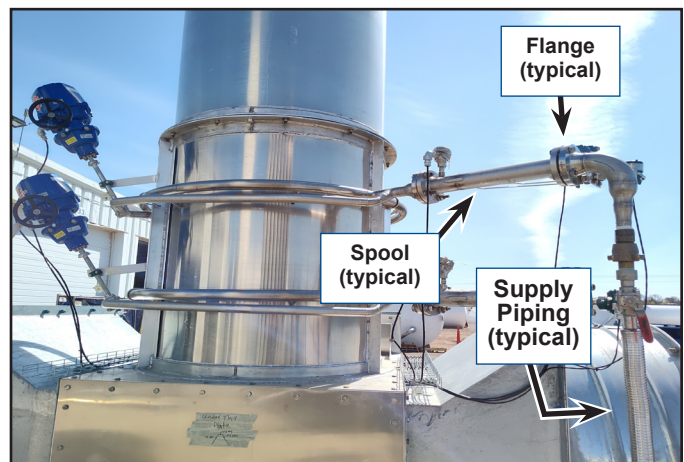

Electrical Assembly

Line Power



Danger! Check to make sure there is no power to the Line Power Wires before you connect the Wires to the Circuit Breaker in the Control Panel. Failure to observe this safety precaution can result in serious injury or death.

1. Remove the plug covering the **Line Power Access Port**.
2. Route the **480 VAC Line Power Cable** up through the **Line Power Access Port**.
3. Connect the **Line Power Wires** to the **Circuit Breaker** in the Control Panel according to the Electrical Diagram in the Control Panel Drawings. (Refer to [Appendix C – Control Panel Electrical Drawings](#)).
4. Connect the **Ground Wire** to the **Ground Lug** in the Control Panel.

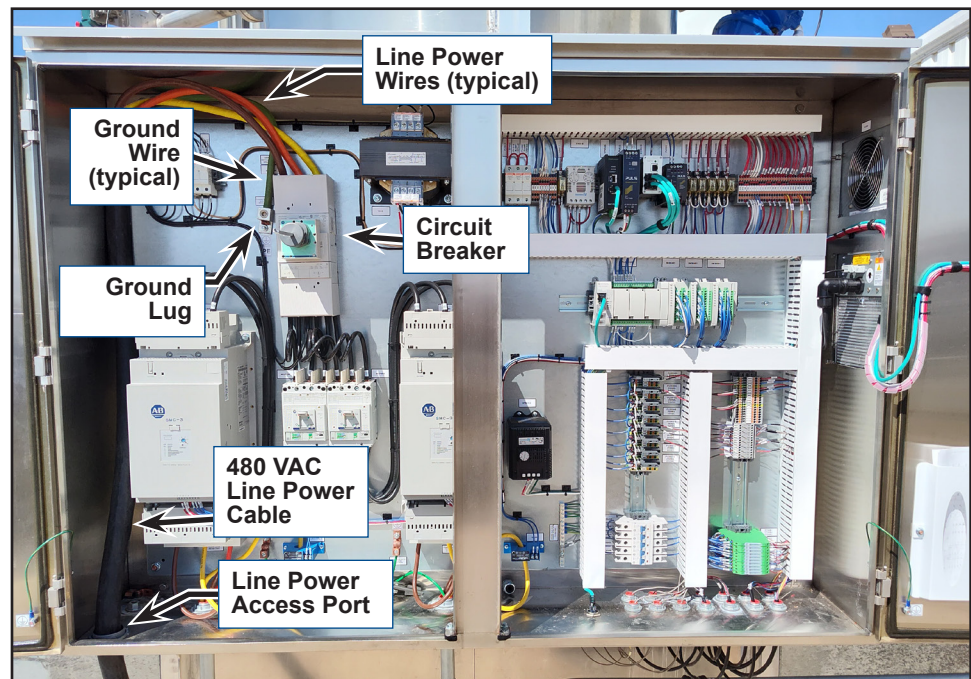

Signal Wires

Connect all sensor cables on the spool (RTD and two pressure transmitters) and actuator with the matching tagged/colored cables from the wire racks. (Also refer to Appendix C – Control Panel Electrical Drawings for the wire connection locations.)

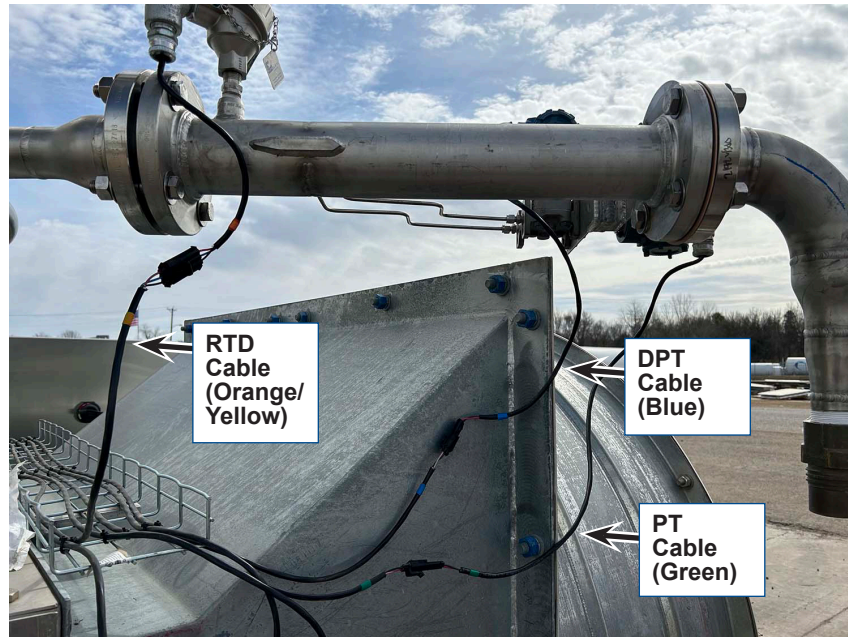

Note: Refer to Appendix E – PLC IP Configuration for the PLC IP Address, Tag Descriptions, Modbus Addresses, etc.

Remote Connection

The FAD is equipped with the ability to remotely monitor and control its functions through a Secomea SiteManager which works in tandem with LinkManager and GateManager. Although SiteManager has its own IP address and does not interface with the data or information shared on your ethernet network, the Secomea must first be configured to work with your LinkManager account. This section is used to help understand how the remote connection is established with Secomea SiteManager. The procedure will involve a configuration of the SiteManager unit which is installed in the control panel of the FAD system.

Formatting the USB drive

The first step in configuring the Secomea SiteManager will be to make sure the USB drive is in the correct format. This is essential otherwise the Secomea SiteManager will not download the configuration file. To do this, right click the USB drive in the file explorer and change the format to FAT32.



Note: Changing this format will erase anything you previously had stored on the USB.

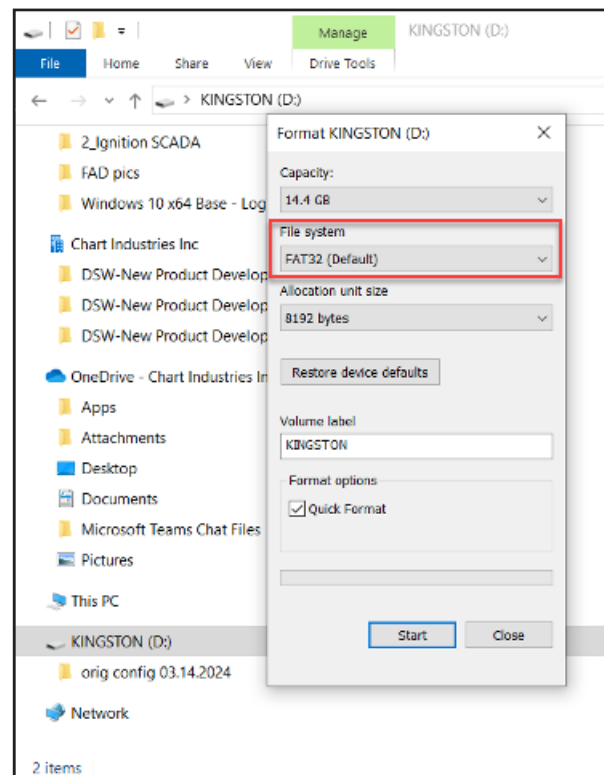
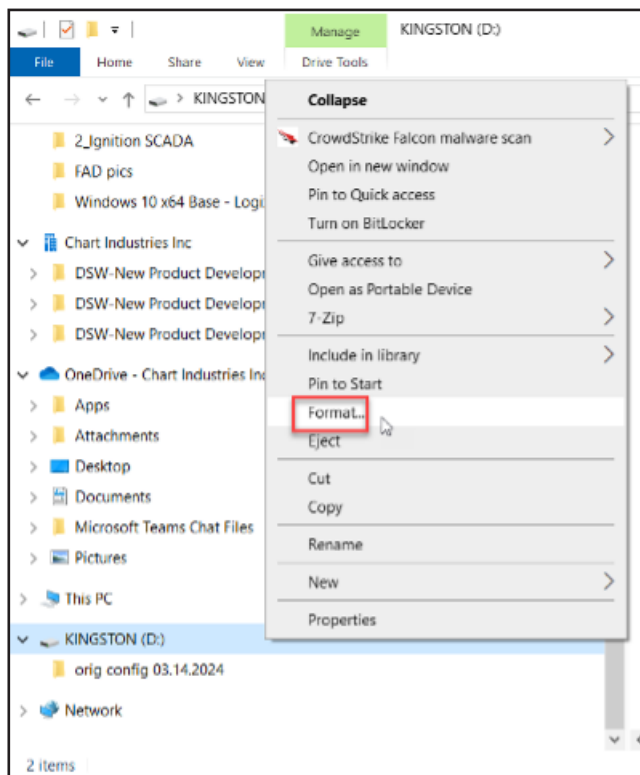

Creating the Configuration File

The next step is to create the configuration file SITEMANAGER.CFG. The link below shows the same information shown in this document but without the Chart example: <https://kb.secomea.com/docs/configure-a-sitemanager-with-an-usb-stick>



Note: Customer should be sold a LinkManager Mobile license

EXAMPLE – Connecting to a (Chart) LinkManager Account

This example uses a Chart device to demonstrate how to connect to a LinkManager account. Go to your GateManager online account:

- For this Chart internal example, the domain is named gm21.secomea.com
 - Go to your tree on the left of the screen where you will want the connection domain
- Click “Create USB Configuration”
- Popup appears with editable fields applicable to the SiteManager
- Name the SiteManager in the “Appliance Name” field
 - This name will show up in the tree view if configured properly.
- Create a password in the “Admin Password” field.
 - This is the password that it will ask when you remotely connect

The screenshot shows the GateManager web interface. On the left is a tree view with 'Chart Industries' and 'Chart Products'. The main area displays 'Domain Overview' for 'Chart Products'. A red box highlights the 'Create USB Configuration' button, with a red arrow pointing to it and the text 'click this'. Below this, a 'Create USB Configuration' dialog box is open. It contains the following fields and options:

- GateManager Address: gm21.secomea.com
- Domain Token: chartproducts
- Appliance Name: (empty)
- Read Proxy: SHOW
- UPLINK Ports: SHOW
- UPLINK2 Mobile: SHOW
- UPLINK2 WiFi: SHOW
- UPLINK2 Port: SHOW
- Admin Password: (empty)
- Enable debug log:
- Disable USB Config:
- Buttons: Create, Cancel

Red arrows point to the 'Appliance Name' and 'Admin Password' fields, with the text 'edit fields here' next to them.



The SiteManager is in the control panel and acts as a bridge between the GateManager and FAD system.

- Click “Show” on the UPLINK Port
 - This is the port that connects the SiteManager to the internet
- Click “Mode” dropdown and select “Use DHCP”

- Click “Show” on the Dev1 Port
 - Local devices connect to the Secomea SiteManager through this port
 - Assign the IP address and Subnet mask of the SiteManager
- Click “Mode” dropdown and select “Use Static Configuration”
 - If multiple FAD systems on site, need unique IP for each SiteManager

Create USB Configuration

Create a configuration file suitable for initializing an appliance via a USB flash stick.

Fill in some of the fields below, and then click on Create to download the configuration to your PC. You should save this file on a FAT32 formatted USB flash stick in a file named SITEMANAGER.CFG.

GateManager Address: gm21.secomea.com

Domain Token: chart-products

Appliance Name:

Web Proxy: Show

UPLINK Port: Show 192.168.1.250 255.255.255.0

UPLINK2 Mobile: Show

UPLINK2 WiFi: Show

DEV1 Port: Hide

Mode: Use Static configuration

IP Address / Subnet mask:

Admin Password:

Enable debug log:

Disable USB Config:

Create Cancel



Note: IP address can be identical to this example as the system components' IP are assigned when assembled.

PLC: 192.168.1.1

HMI: 192.168.1.2

Once the configuration has been setup, click “Create” at the bottom and save the file “SITEMANAGER.CFG” to your USB base directory.

Configuring the Secomea SiteManager

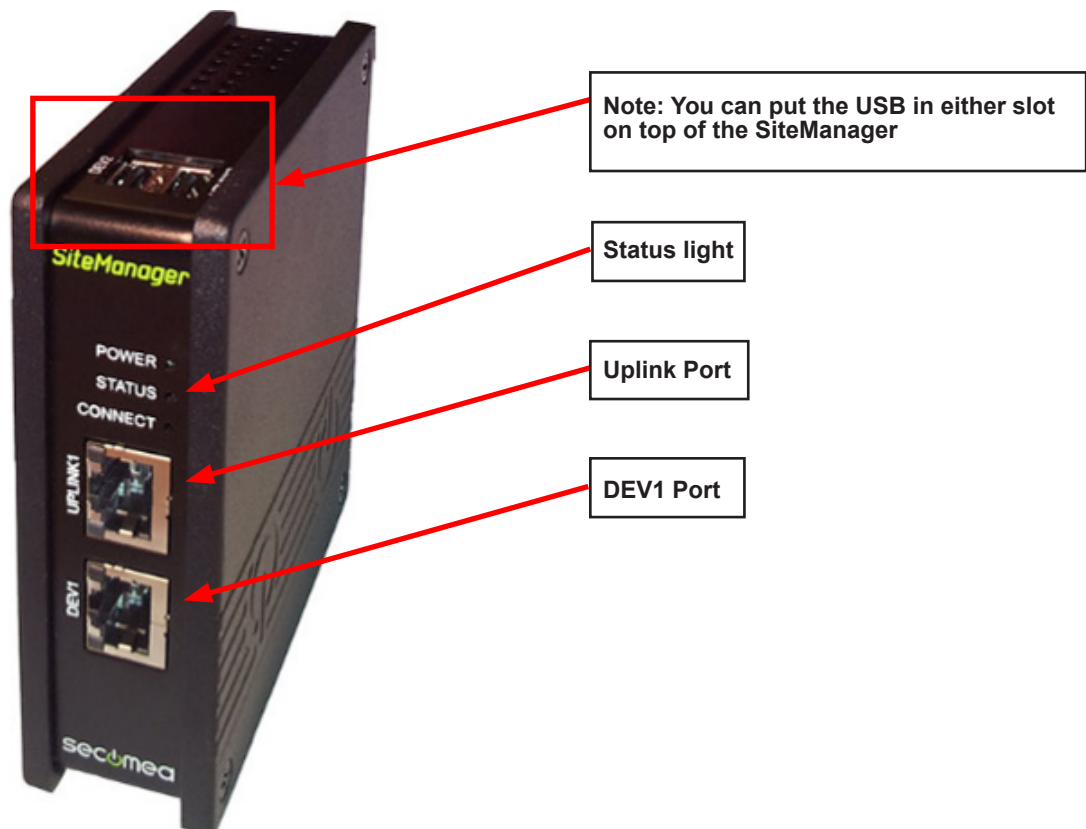

1. With unit powered on and connected to the internet via the UPLINK port, wait for the status light (front of unit) to be steady red.
2. Insert the USB into the top of the Secomea SiteManager. Either USB port will work.
3. Lights will flash, wait for the status light to turn green (about 30 seconds)
4. Once the light has turned green, that means the configuration is finished and the connection is established to the GateManager
 - USB may be removed
 - Confirm configuration via connecting to the SitManager’s Dev1 port
 - Open browser and go to `https://192.168.1.250` (IP address of SiteManager from config earlier)
 - If prompted for username and password, then it is configured

Setting up Remote Access Through GateManager

The remote access will be done through the GateManager website which must be accessed through a web browser. Chart internal example -> gm21.secomea.com.

The link below contains the same information in the following section.

<https://kb.secomea.com/docs/sitmanager-agent-setup>

5. Log in to GateManager
 - Secomea SiteManager should be visible under the GateManager domain tree

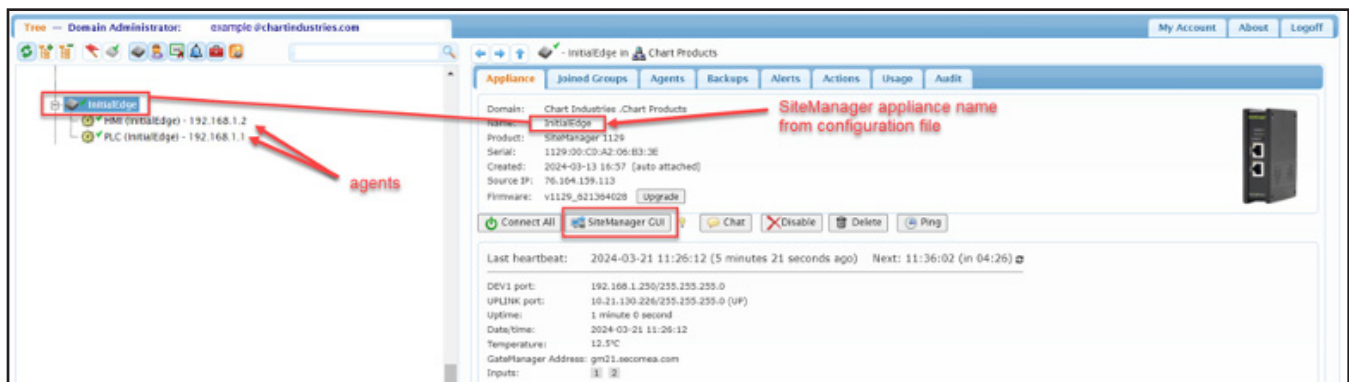

1. From the “Setup” front page view of the SiteManager GUI, click on “GateManager”:

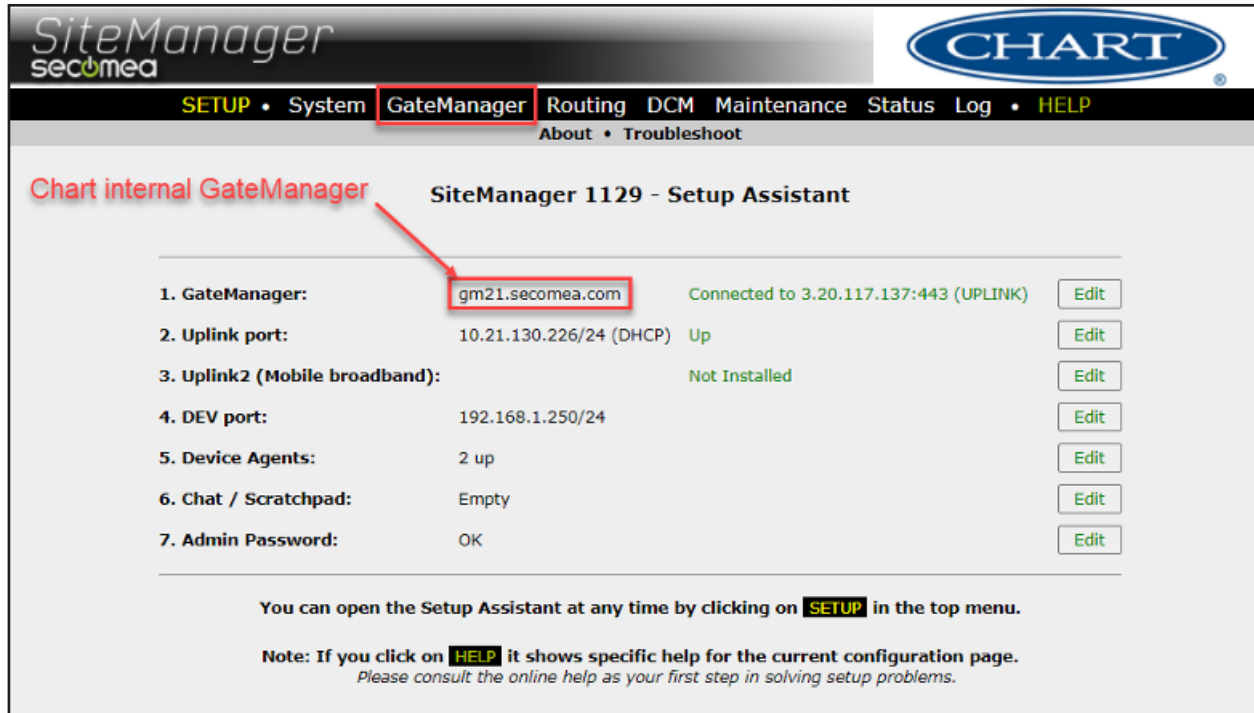

The screenshot shows the SiteManager GUI with the 'GateManager' menu item highlighted in the top navigation bar. The main content area is titled 'Chart internal GateManager' and 'SiteManager 1129 - Setup Assistant'. It displays a list of configuration items, each with an 'Edit' button:

Item	Value	Status	Action
1. GateManager:	gm21.secomea.com	Connected to 3.20.117.137:443 (UPLINK)	Edit
2. Uplink port:	10.21.130.226/24 (DHCP)	Up	Edit
3. Uplink2 (Mobile broadband):		Not Installed	Edit
4. DEV port:	192.168.1.250/24		Edit
5. Device Agents:	2 up		Edit
6. Chat / Scratchpad:	Empty		Edit
7. Admin Password:	OK		Edit

Below the table, there is a note: "You can open the Setup Assistant at any time by clicking on **SETUP** in the top menu." and another note: "Note: If you click on **HELP** it shows specific help for the current configuration page. Please consult the online help as your first step in solving setup problems."

2. Click on “Agents”:

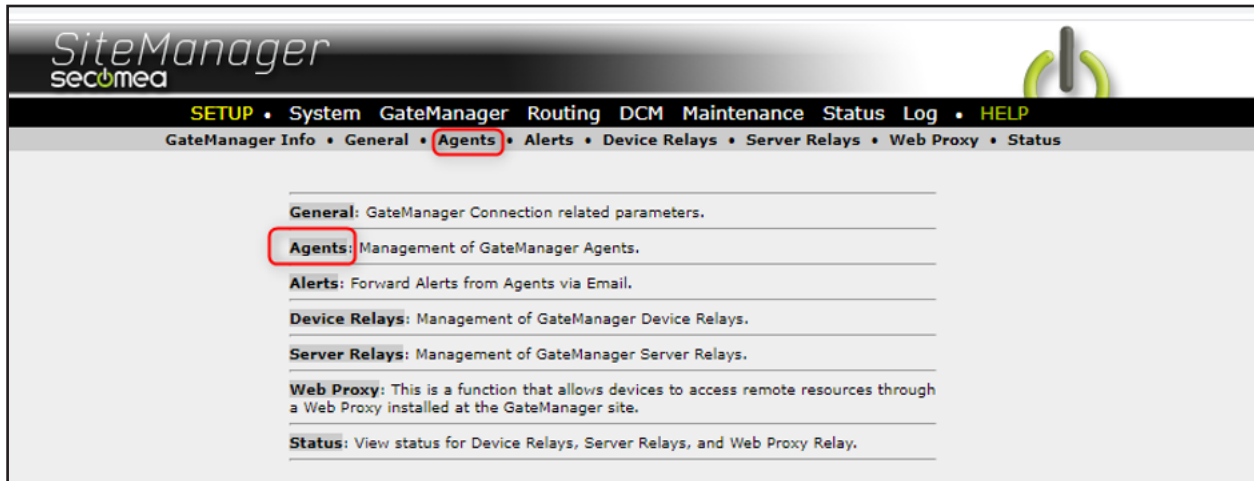

The screenshot shows the SiteManager GUI with the 'Agents' menu item highlighted in the top navigation bar. The main content area is titled 'GateManager Info' and 'Agents'. It displays a list of configuration items, each with a description:

Item	Description
General:	GateManager Connection related parameters.
Agents:	Management of GateManager Agents.
Alerts:	Forward Alerts from Agents via Email.
Device Relays:	Management of GateManager Device Relays.
Server Relays:	Management of GateManager Server Relays.
Web Proxy:	This is a function that allows devices to access remote resources through a Web Proxy installed at the GateManager site.
Status:	View status for Device Relays, Server Relays, and Web Proxy Relay.

3. Under GateManager Agents click on “New”:



The screenshot shows the SiteManager GUI with the 'Agents' menu item highlighted in the top navigation bar. The main content area is titled 'GateManager Agents'. It displays the text "Using 0 of 100 agents" and three buttons: "Refresh", "New", and "Search". The "New" button is highlighted with a red box.

4. Enter the information about your device:
 - Device Name – open text field
 - Device Type – from dropdown
 - Enter Device IP & Parameters
 - HMI: 192.168.1.2
 - PLC: 192.168.1.1

5. Click on “Save” for your new Agent:

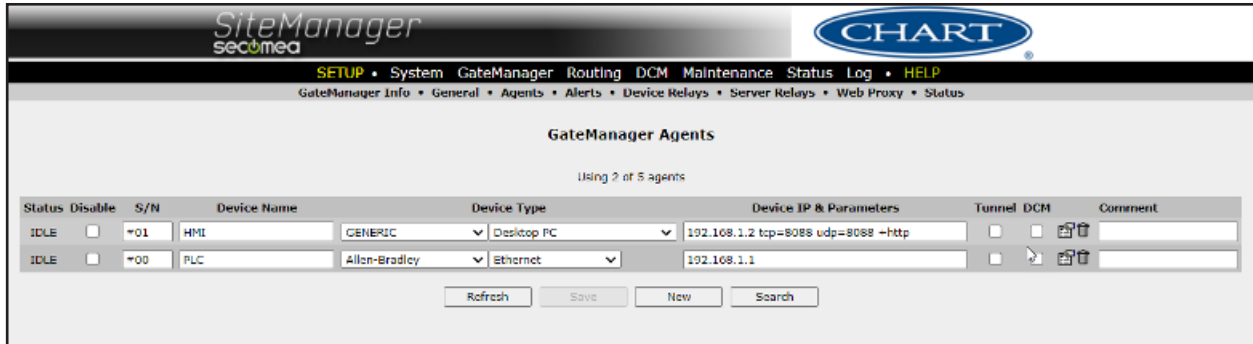

6. Check that your Agent is available in your domain tree view:

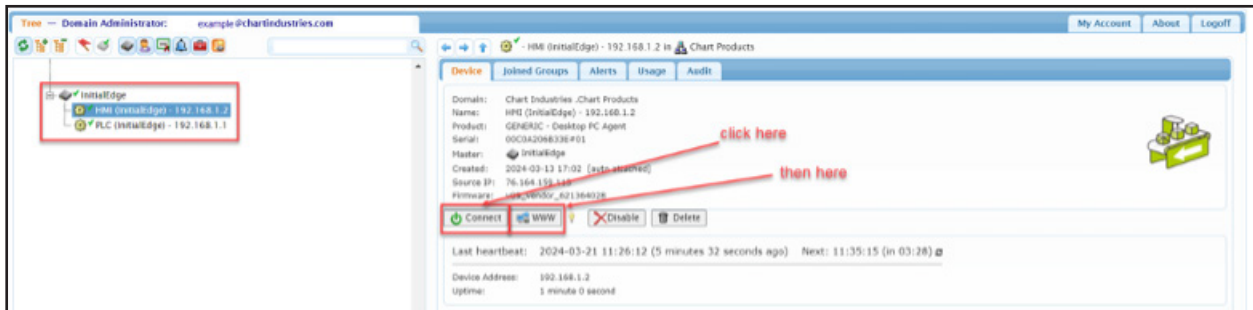

7. Once agents are set up, you can view/connect to the device in your link tree. Then you can click the “WWW” button to bring up a webpage view of the HMI. Once there, you will be prompted for a username and password.

username: defmaint

password: 3000

8. After logging in, your webpage will be a fully functional HMI as if you were at the control panel and you can control the FAD from there.

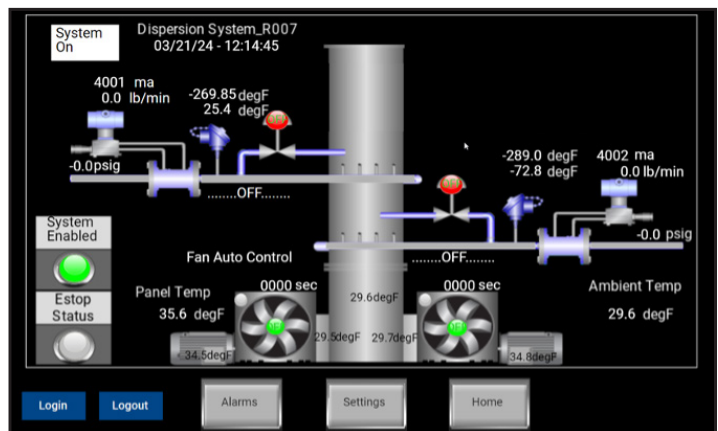

System Controls

Control Panel

The controls on the front of the Control Panel function as follows:

- **Blower Override** – key switches; when rotated clockwise will run the adjacent blower motor independent of the system/HMI status.
- **Main Electrical Disconnect** – controls the AC line power to the Control Panel.
- **HMI** – (Human/Machine Interface) touch-screen controller; displays the screens that allow the Operator to run the Vaporizer, view the status of the machine components and operating parameters, and change the system settings.
- **EMERGENCY STOP** – maintained palm switch; will shut down the power to the blower motor soft starters when pressed but will not stop the flow to the Vaporizer. To disengage the **EMERGENCY STOP**, rotate the switch clockwise.
- **Allen-Bradley Soft Starters (2)** – temporarily reduce the load and torque in the Air Blower drives, and reduce the electric current surge of the motors during startup.
 - The front of the unit shows the LED fault codes.
 - Pressing the **PUSH TO RESET** button resets the fault.

Also refer to the manufacturer's technical documentation in [Appendix B](#).



Note: To open a Control Panel door:

1. Rotate and hold the key in the full clockwise position.
2. Lift up on the handle trigger, then rotate the handle clockwise.

Also note that the left-hand door (with the Electrical Disconnect) must be opened before you can open the right-hand door.

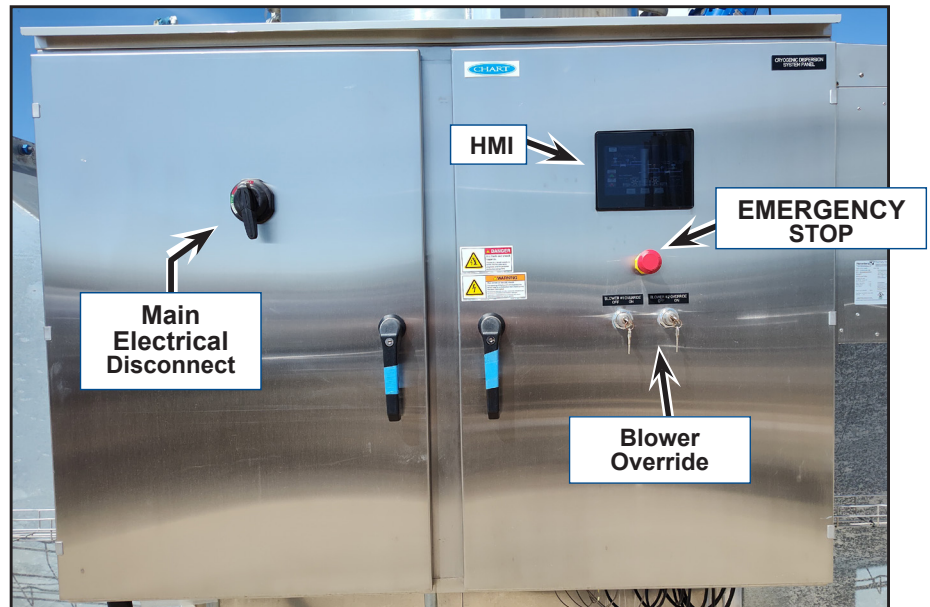

HMI Screens

Home Screen

The Home Screen is the screen from which the Operator runs the Vaporizer. The home screen displays the current date, time, program revision level, the status of the system components, and the process parameter values.

Pressing () displays the Home Screen.

The fields and buttons on the Home Screen function as follows:

- SYSTEM OFF/ON** button – switches the Vaporizer on and off. If the system is off the unit will not detect liquid or prompt the fans to turn on.
- PT (Pressure Transmitter) Icons (1-3)**, the fields above the icons display the corresponding transmitter current output in milliamps, and the gas/liquid flow rate in pounds per minute. Note that the flow rate will change based on whether it senses liquid or gas.
- Bypass Valve Icons ON/OFF (1-3)** – display the corresponding bypass valve state; green is ON (open), and red is OFF (closed).
- RTD (Resistance Temperature Detector) Icons (1-3)** – the top field above the icons displays the temperature threshold from gas to liquid. The bottom field displays the gas/liquid temperature in the corresponding spool in degrees F.
- Software Revision** field – displays the current system software revision.
- Phase Indicator Fields (1-3)** – display the state of the material in the corresponding Spool. The possible phases are OFF, INITIAL GAS, LIQUID and END OF LIQUID.
- Countdown Timer** field – displays the time the blowers will continue to run after the phase indicator displays OFF.
- Fan Blower Hub Icons (2) & Motor Icons (2)** – the Hub and Motor Icons indicate the following:
 - A green Hub Icon displaying ON indicates the fan is spinning.
 - A green Hub Icon and green Motor Icon indicate that the blower motor is up to speed.
 - A green Motor Icon only indicates that the blower motor was switched on using the Blower Override key switch.

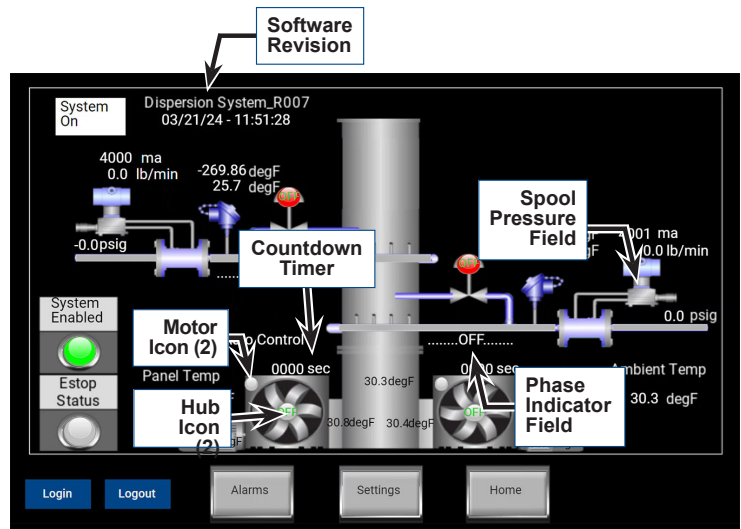
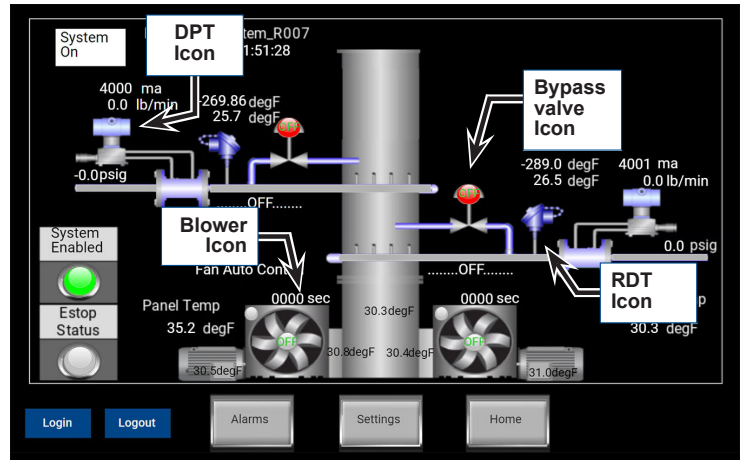

- A red **Motor Icon** indicate a blower motor fault. (Refer to the *Blower Motor Controller Blink Codes in Maintenance and Adjustments*)
- A white **Hub Icon & Motor Icon** indicates that the blower motor is off.
- **Spool Pressure Fields (1-3)** – display the gas/liquid pressure in the corresponding Spool.
 - Will display **System Enabled** with the Fan Local Control and **SYSTEM ON** button active, or with the Fan Remote Control enabled with the system having received a remote “heartbeat” Ethernet signal.
 - Will display **System Disabled** with the Fan Local Control and the **SYSTEM OFF** button active, or with the Fan Remote Control disabled with the system not having received a remote “heartbeat” Ethernet signal.

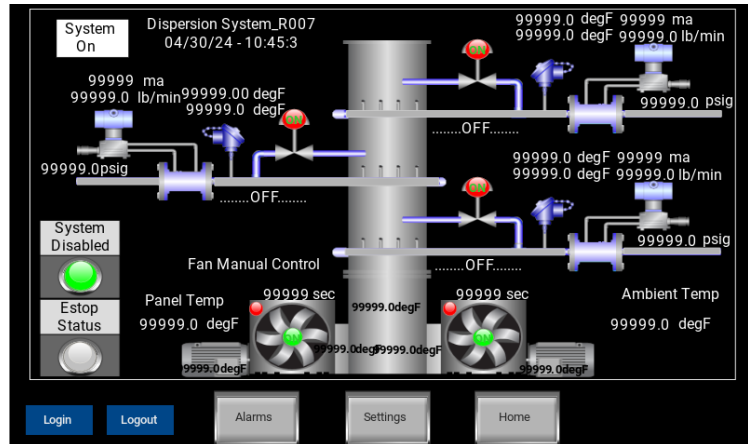

- **ESTOP STATUS ACTIVE** indicator – displays the state of the **EMERGENCY STOP** push button on the Control Panel. When the estop is engaged the indicator will display red, otherwise it will remain white.
- **Panel Temp** field – displays the temperature inside the Control Panel in degrees F.
- **Ambient Temp** field – displays the ambient temperature in degrees F. The **Ambient Temperature Thermocouple** is mounted on the right-hand blower grill.



Note: The Temperature fields on the Home Screen are inputs from the corresponding thermocouples.

- **Motor Temperature Fields (2)**– display the corresponding blower motor temperature in degrees F.
- **Baffle Bottom Temperature Fields (3)** – display the temperature at the bottom of the corresponding baffles in degrees F.

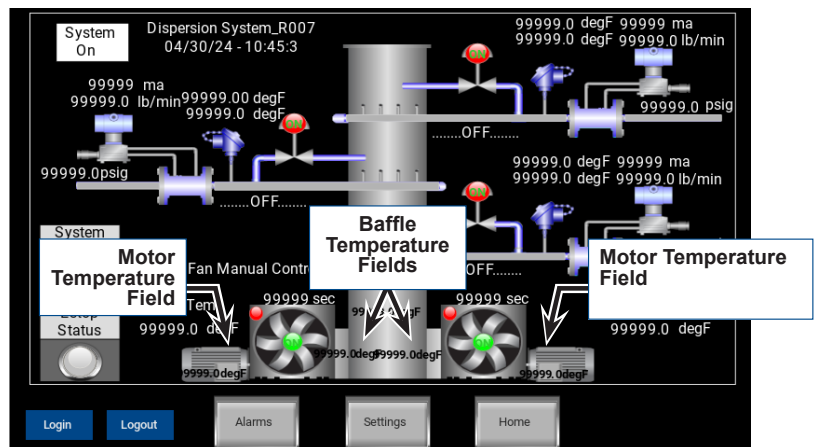

- **Alarms** Icon – displays the Alarms Screen; will flash when an alarm is active.
- **Login** Icon – displays the **SECURITY MANAGER** pop-up from which the Operator can enter the user name and password to access the Settings Screen.
- **Settings** Icon - available once logged in, navigates to the settings screen.

-  Icon - logs the user out, removing access to the settings button/screen.

Settings Screen

The Settings screen allows an Operator with the appropriate credentials to view and change the Header Settings, toggle between the Auto and Manual modes, turn the fans on and off, open and close the bypass valves, and reset the Header Settings to the factory default values.



Note: On units equipped with fewer than the maximum three headers, fewer setting displays will be shown on the Header Settings Screen.

The screenshot shows the Settings Screen with two columns of settings for Header 1 and Header 2. Below the settings are control buttons for Auto Control, Fan 1, Fan 2, Valve 1, and Valve 2. At the bottom, there are buttons for Alarms, Settings, and Home, along with a Factory Reset button. The status bar at the bottom shows CustomerReq: OFF, SCADA_Heartbeat: 4896, Fan2Delay: 10 sec, and TurningFanOffset_1: 60 sec.

Header 1 Settings		Header 2 Settings	
FlowLiqSpan_1	2290 lb/min	FlowLiqSpan_2	1942 lb/min
FlowGasSpan_1	290 lb/min	FlowGasSpan_2	203 lb/min
PressureSpan_1	150 psig	PressureSpan_2	150 psig
PressureZero_1	0.0 psig	PressureZero_2	0.0 psig
TempToLiqOffset_1	30 degF	TempToLiqOffset_2	30 degF
WarmHeaderThreshold_1	-240 degF	WarmHeaderThreshold_2	-240 degF
GasFlowThreshold_1	20 lb/min	GasFlowThreshold_2	20 lb/min

Control Buttons: Auto Control, Fan 1 Man Off, Fan 2 Man Off, Valve 1 Man Off, Valve 2 Man Off, Setup, Factory Reset

Status Bar: CustomerReq: OFF, SCADA_Heartbeat: 4896, Fan2Delay: 10 sec, TurningFanOffset_1: 60 sec

Navigation: Alarms, Settings, Home

The fields and buttons on the Settings Screen function as follows:

- **Header 1/2/3 Settings fields:**
 - **FlowLiqSpan_1/2/3: xxxlb/min** field – displays the liquid flow rate at which the transmitter outputs a 20mA signal.
 - **FlowGasSpan_1/2/3: xxxlb/min** field – displays the gas flow rate at which the transmitter outputs a 20mA signal.
 - **PressureSpan_1/2/3: xxxpsig** field – displays the pressure at which the pressure transducer outputs a 20mA signal.
 - **PressureZero_1/2/3: x.xpsig** field – offset value that allows you to zero the pressure transducer. For example, with no pressure in the Header, the transducer pressure field on the Main screen reads 5 psi. You can then enter 5 psig in the **PressureZero_1/2/3: x.xpsig** field to change the displayed pressure value on the Main screen to zero.
 - **TempToLiqOffset_1/2/3: xxdegF** field – displays the temperature offset that is added to the gas-to-liquid target temperature. The gas-to-liquid target temperature is predicted based on the current header line pressure and is used to trigger the system from gas phase to liquid phase.
 - **WarmHeaderThreshold_1/2/3: -xxxdegF** field – displays the temperature above which the system will begin to switch the blowers off. The blowers will continue to run for the time displayed in the **TurningFanOffset_1:** field.
 - **GasFlowThreshold_1/2/3: xxlb/min** field – displays the gas flow rate at which the corresponding bypass valve will open and the blower motors will start.

- **Auto/Manual Enabled** button – Allows the user to toggle the manual override of the valves and fans.
- **Fan 1/2 RUN/OFF** buttons - switch the corresponding blower fan on and off, if manual mode is enabled.
- **Valve 1/2/3 OPEN/CLOSED** buttons – open and close the corresponding bypass valve, if manual mode is enabled.
- **Factory Reset** button – resets the Header Settings to the factory default values.
- **TurningFanOffset_1: xxsec** field – displays the time during which the blowers will continue to run after the flow to the spool(s) stops.
- **Fan2Delay: xxsec** field - displays the time delay between fan 1 starting up and fan 2 starting up. The default value is 10 seconds to prevent excess torque and current draw on the system at the same time.
- **Setup button** - (password protected) used during initial commissioning to assign number of headers and cryogen types to each header (this assigns default values for each header). If you believe the defaults were set incorrectly or would like to change cryogen types contact Chart

Pressing a number value field on the Header Settings screen displays a keypad onto which you can enter a new value. (The **FlowLiqSpan_1/2/3: xxxlb/min** field is shown here as an example.)

Pressing the  (enter) button will enter the new value onto the screen.

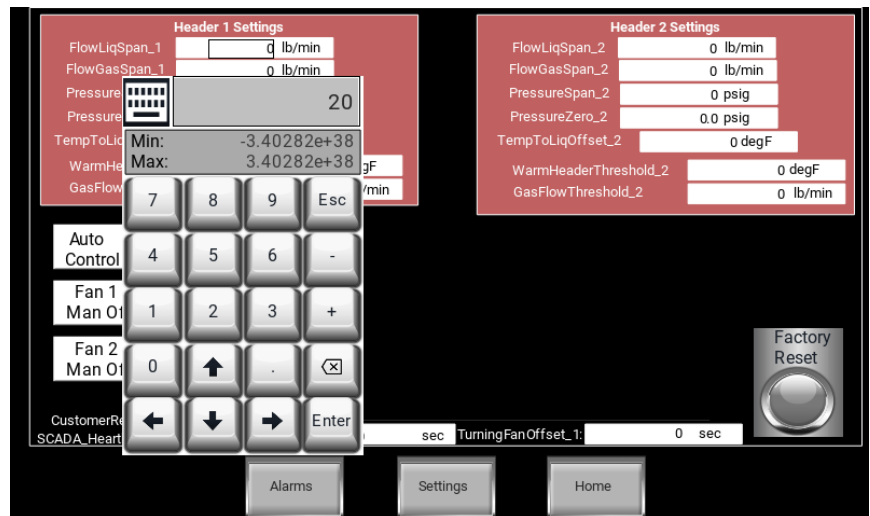

Setup Screen

The Setup screen allows Chart personnel with the appropriate credentials to view and change the number of headers and cryogen type assigned to each.

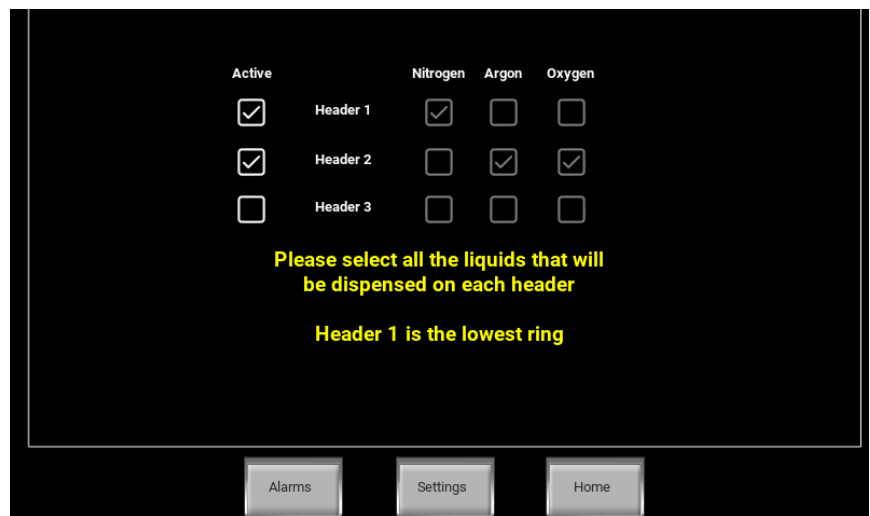

Alarms Screen

The Alarms screen shows all active alarms.

The buttons on the Alarms screen function as follows:

- **Back** button – selects the previous alarm event field.
- **Forward** button – highlights the alarm event field and displays the **Accept** button.
- **Check/Uncheck All** button - Allows the user to select all alarms to acknowledge at one time.
- **Ack(nowledge)** button - clears the alarm. Note that if the alarm condition has not been cleared, the alarm message will reappear.
- **History** button - shows alarm history
- **Refresh** button - refreshes alarm history

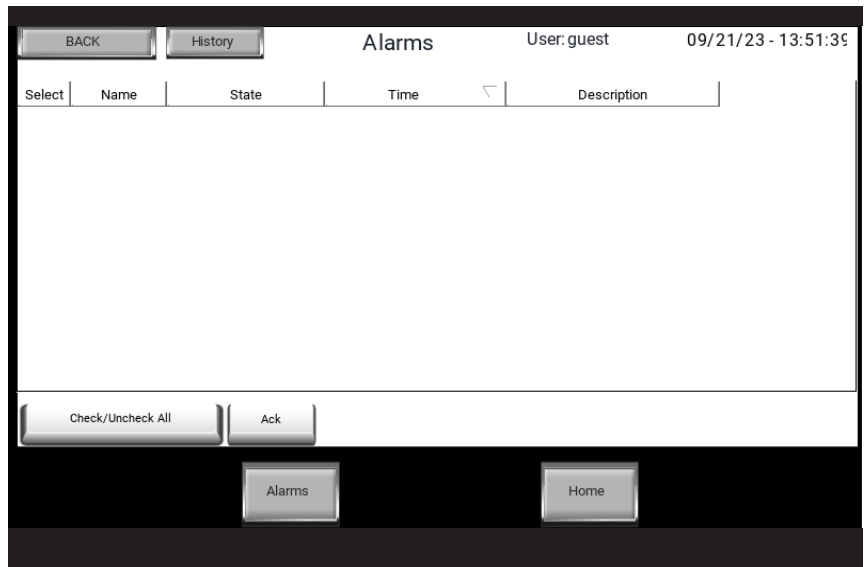

Operation

Before You Run the Vaporizer

1. Make sure the **EMERGENCY STOP** switch is disengaged. To disengage the switch, rotate the switch clockwise.
2. Rotate the **Main Electrical Disconnect** counterclockwise to its **ON** position.



Vaporizer Operation

The HMI will display the Home Screen when the machine power is switched on.

1. Press the **SYSTEM OFF** button.

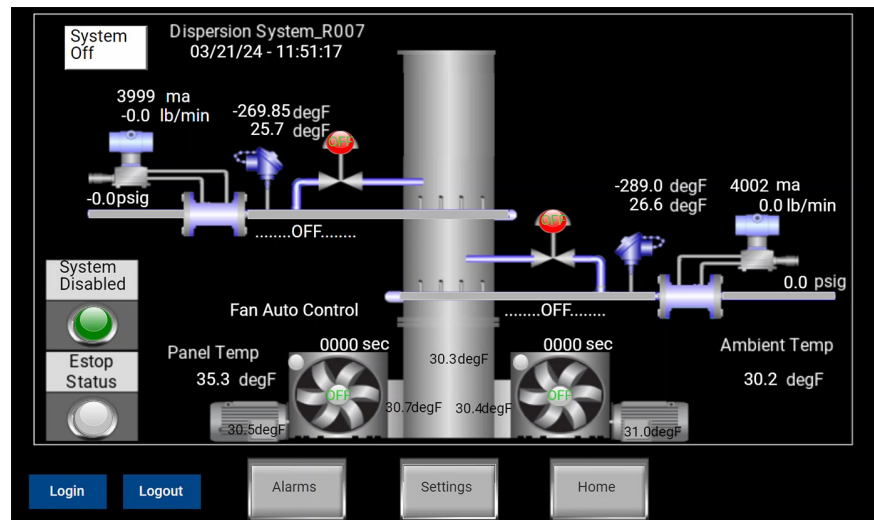

The Home Screen will display **SYSTEM ON**.

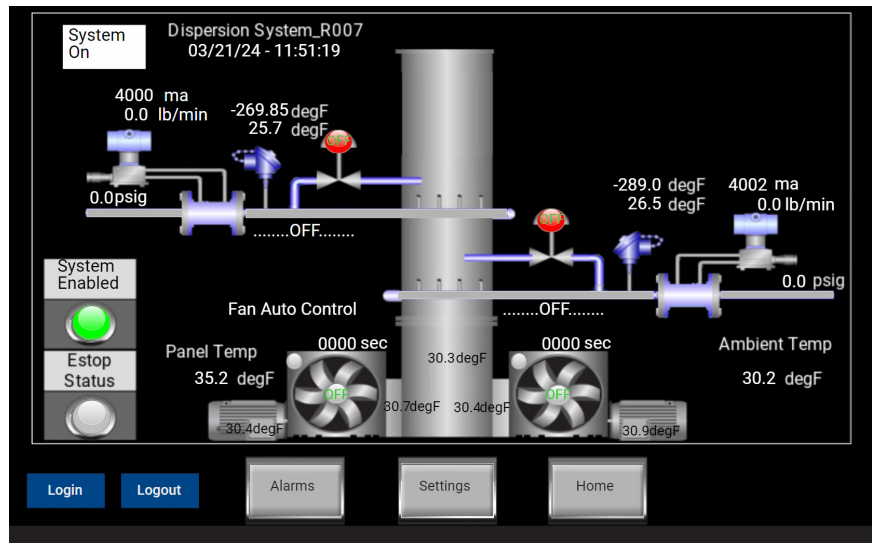

2. Once gas is introduced to the spool and the flow rate in the spool reaches the gasflowthreshold (typically 20 lb/min):

- a. The bypass valve on the spool feeding gas to the Vaporizer will remain open and the bypass valve icon will be green and display **ON**.
- b. The blower motors will start, the blower hub icons will change state to green and display **ON**, and the motor icons will change state to green. Note that the blower motor for fan 1 will start first, then the blower motor for fan 2 will start after a short delay.

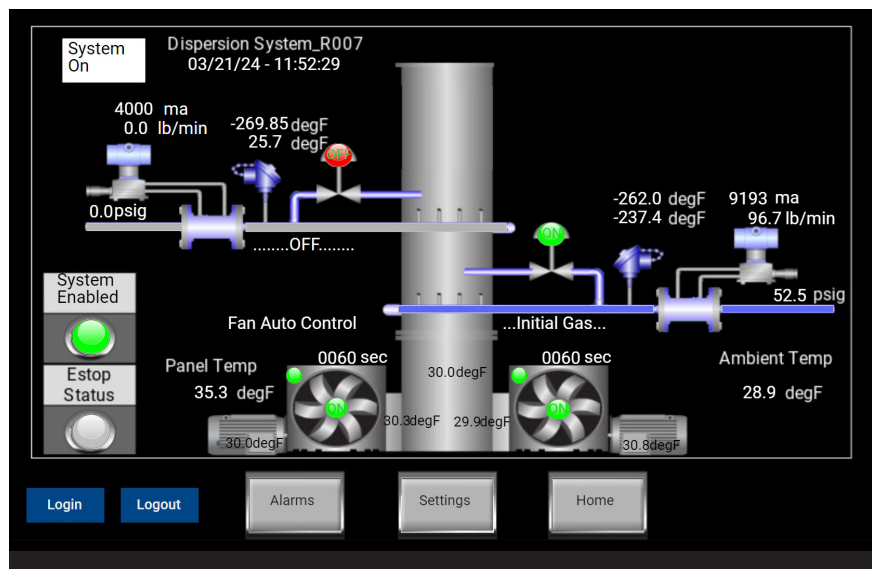

- c. The phase indicator field will display **Initial Gas**.
- d. The spool color will change state to blue to indicate gas flow.

3. Once the temperature at the **RTD** (Resistance Temperature Detector) drops to the gas-to-liquid temperature threshold:

- a. The bypass valve on the spool will close.
- b. The bypass valve icon will change state to red and display **OFF**.
- c. The phase indicator field will display **Liquid**.
- d. The spool color will change state to cyan to indicate liquid flow.
- e. The DPT field will show the liquid flow rate and corresponding current input.

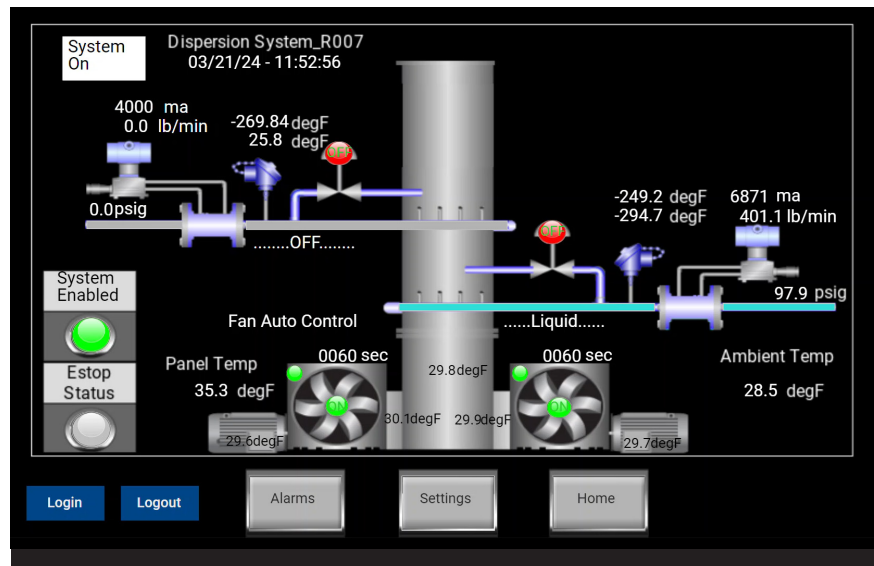

4. When the temperature in the spool rises by the TempToLiqOffset (typically 30 degrees) warmer than the gas-to-liquid threshold, the phase indicator field will display **End Of Liquid**.

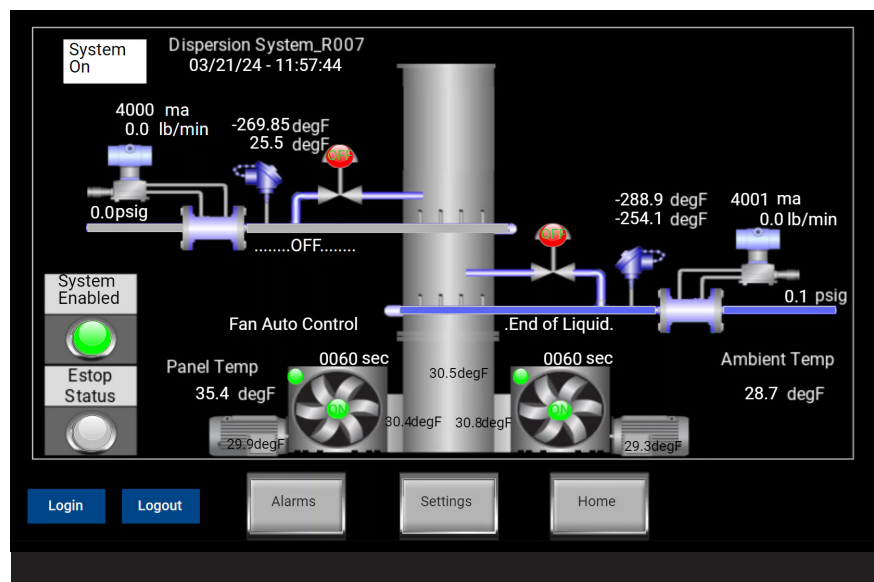

5. When the flow rate in all of the spools is less than the GasFlowThreshold setpoints (factory settings of 20 lbs/min), the headers are warmer than the WarmHeaderThreshold setpoints, and the pressures in the headers are below the PressureTrigSet setpoints, the blowers will begin to shut down by switching on the countdown timer.

The blowers will continue to run for the time displayed in the TurningFanOffSet_1: field on the Header Settings screen (typically 60 seconds).

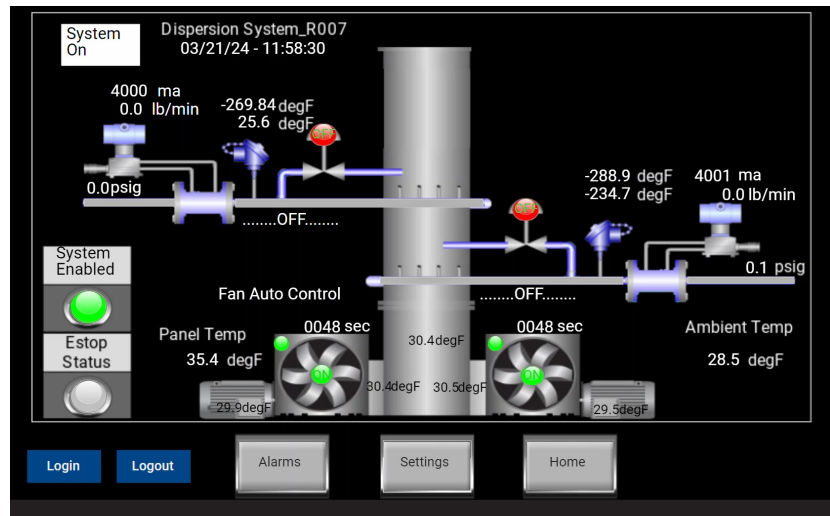

- If the flow rate in any of the spools rises above the GasFlowThreshold setpoint within the time displayed in the TurningFanOffSet_1: field, regardless of the temperature, the countdown timer switches off and the blowers will switch on.
- If the flow rate in any of the spools fails to rise above the GasFlowThreshold setpoint within the time displayed in the TurningFanOffSet_1: field, regardless of the temperature, the blowers will switch off.

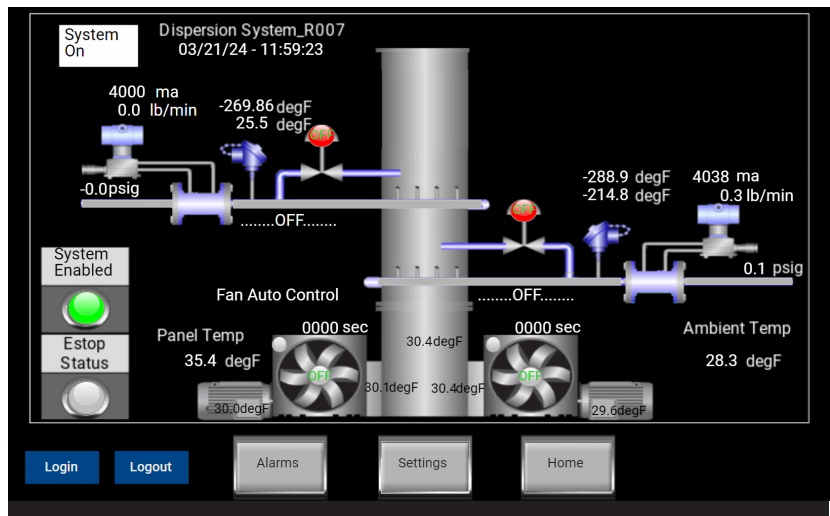

To Run the Blower Motors Independent of the System Controls

1. Rotate the **Blower Override** key switch clockwise to run the corresponding blower motor.
2. To shut off the blower motor, rotate the **Blower Override** key switch counterclockwise.



Note Switching both on simultaneously can result in excess current draw triggering an alarm and excess torque to the unit. Best practice is to wait 10 seconds between switches.



Maintenance and Adjustments



Danger! Follow your company’s safety procedures to lock-out/tag-out the electrical power to the system before performing any maintenance or repairs. Failure to follow this safety precaution can result in severe personal injury or death.

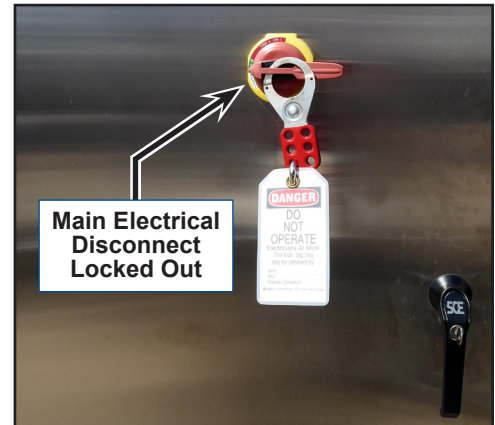

Blower Motor Controller Blink Codes

Refer to the front of the controller to see the definitions of the LED fault codes.

LED	STATUS
ON	RUN / ON
1	OVLDT
2	TEMP
3	PHASE REVERSAL
4	PHASE LOSS/ OPEN LOAD
5	PHASE IMBALANCE
6	SHORTED SCR
7	TEST

Header Settings Screen Functions



Note: The functions available on the Header Settings screen require that the Operator be logged in at the Maintenance access level.

To Log into Access Settings

1. With the **SYSTEM ON**, press the  icon.

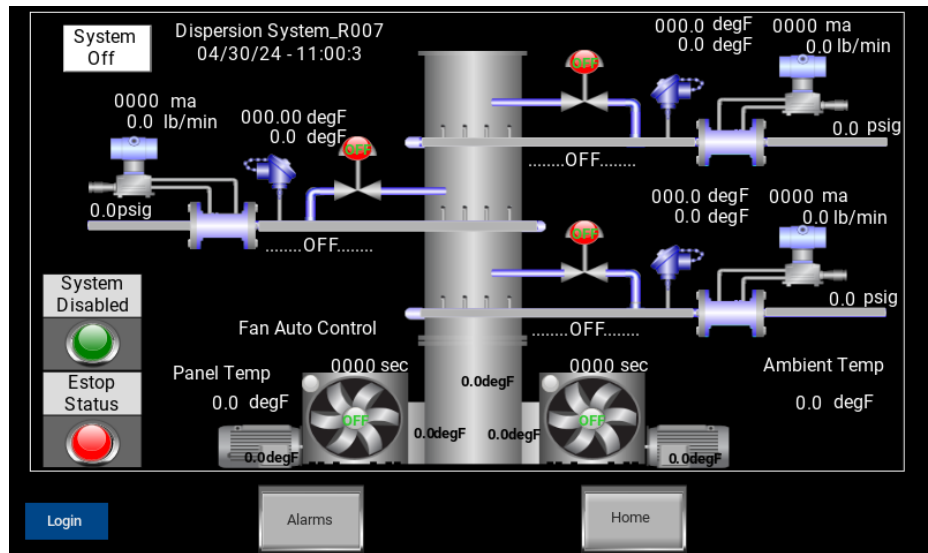

2. Tap username field to bring up keyboard. Type in username (defmaint). Tap Enter.

A screenshot of a login interface. It features two input fields: 'username' and 'password'. Below the 'password' field is a checkbox labeled 'Show password'. At the bottom are two buttons: 'Back' and 'Sign In'.

3. Tap password field to bring up keyboard. Type in password (3000). Tap Enter.

Once entered you may tap the checkbox to display the password.

4. Tap sign in to complete the sign in process. The home screen will now display the settings button and log out button. Tap the settings button to access the settings page.



Note that if the Operator enters the incorrect username or password, the screen will display "Error: the username or password you entered is incorrect".

A screenshot of the login screen after an incorrect attempt. The 'User nam' field contains 'defmaint' and the 'Passwo' field has a single dot. A red error message is displayed at the bottom: "Error : The username or password you entered is incorrect". The 'Back' and 'Sign In' buttons are still present.

To Manually Control the Fans and Valves

1. Press the **Auto Control** button. The button will now display manual control. This now allows manual control of the fans and valves.

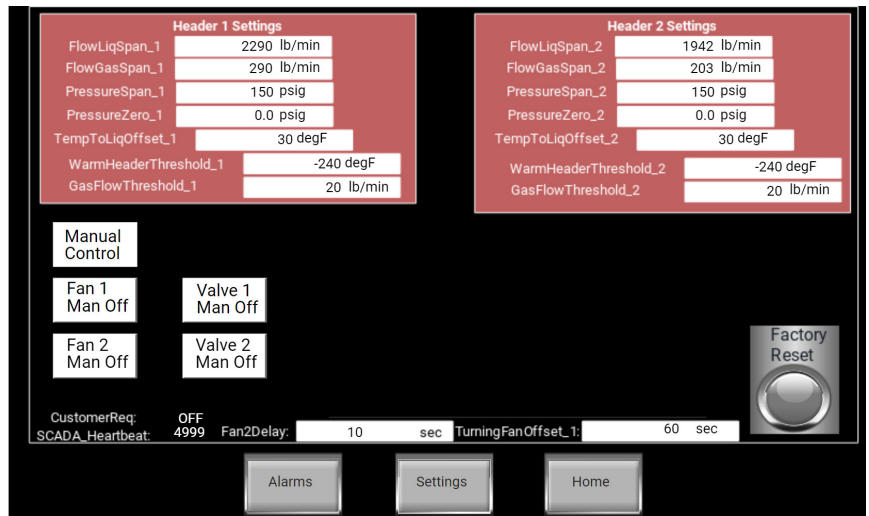
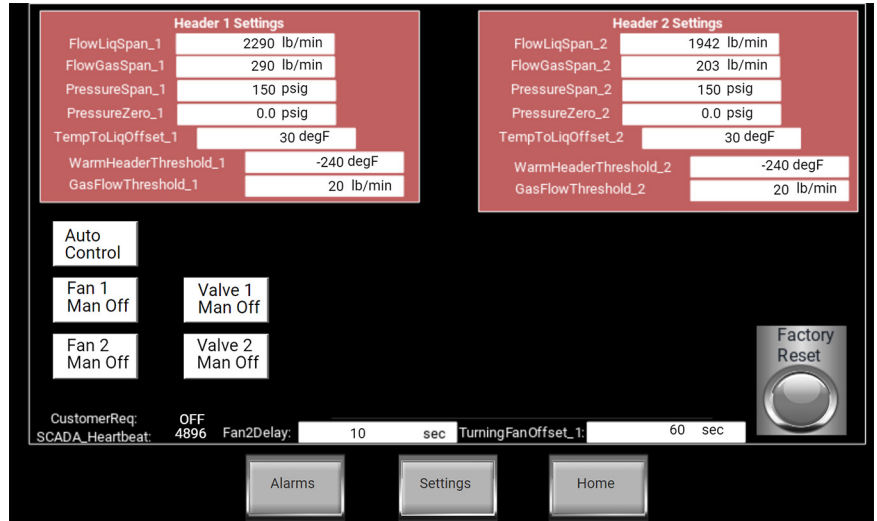

- Tap on the corresponding button you want to control, Fan/Valve Man Off/On 1/2/3, the fan will toggle on/off or the valve will toggle open/closed.

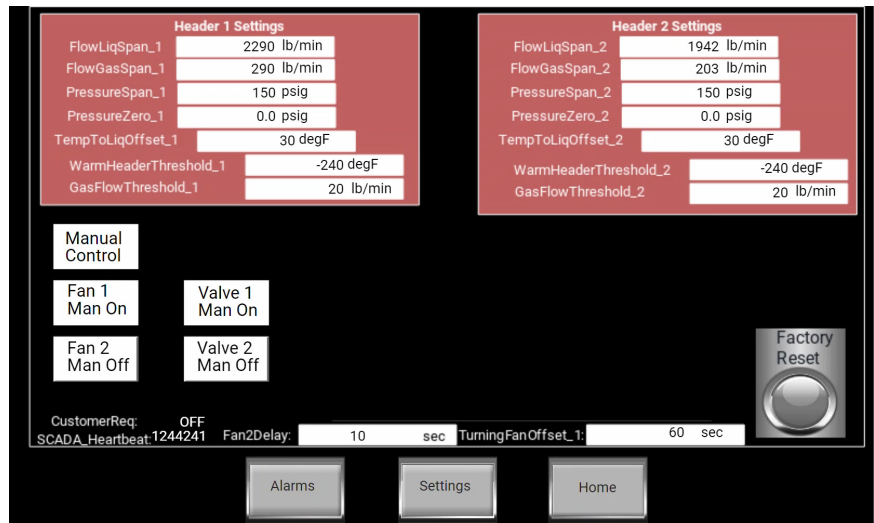

To Change a Header Setting

- Press the number field adjacent to the setting you want to change. (The **FlowLiqSpan_1: 5800lb/min** field is shown here as an example.)

The screen will display the corresponding keypad.
- Enter the new value on the keypad.
- Tap Enter.

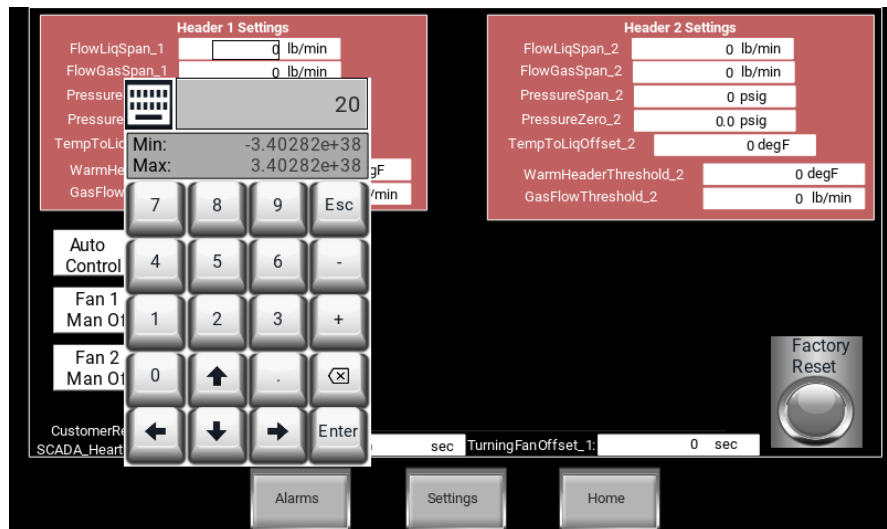

To Reset the Header Settings to the Factory Default Values

1. Press the **Factory Reset** button.
- Each header will reset all parameters based off the cryogen(s) assigned to it. To change default assignments contact Chart.

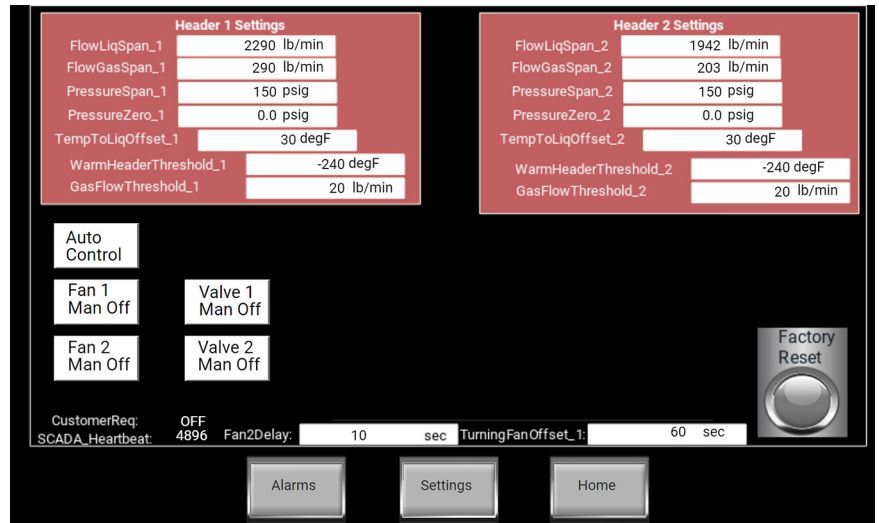

To Set or Change factory Defaults

1. Press the Setup button on the Settings screen.
2. Log in accordingly.



Note: this is a Chart specific password. Contact Chart if the assigned cryogens to each header need to be changed (this determines default values).

3. To activate a header press the corresponding check box in the active column, a check mark should appear if correctly selected.



Note: refer to Appendix A for P&ID and header numbering, the lowest header is header 1.

4. To select the cryogen(s) that will flow through each header, press the corresponding check box(es) (multiple can be selected), check mark(s) should appear if correctly selected.



Note: If a header is not activated, the cryogen options won't be available to select.

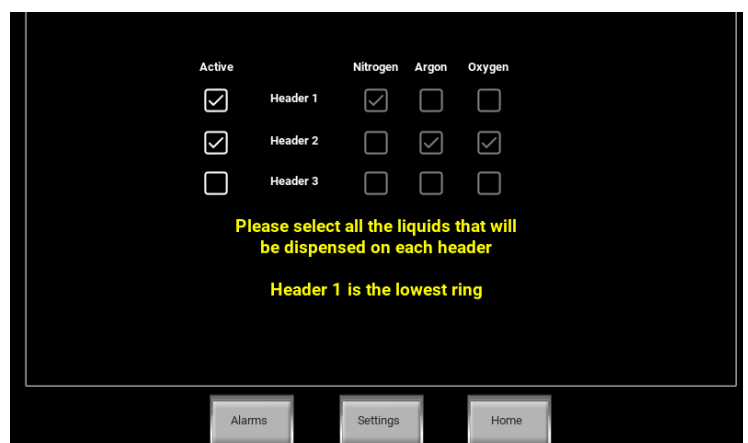
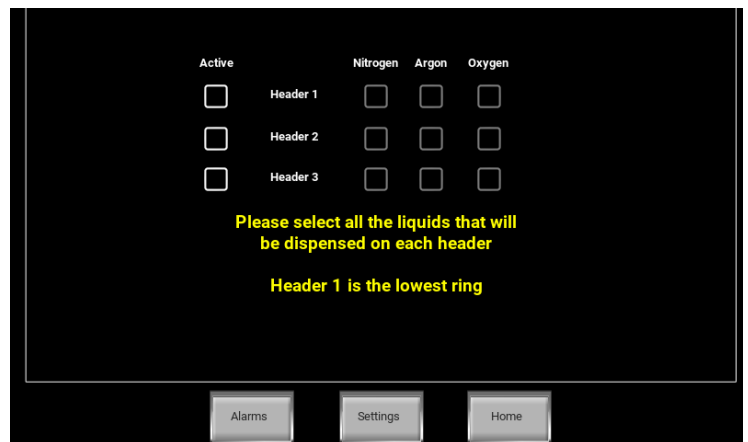

To Enable Remote Connectivity

1. Press the **Local Mode Enabled** button.



Note: That when the **Remote Mode Enabled** button is displayed, the **SYSTEM OFF/ON** button will be hidden and the **System Enabled/Disabled** indicator on the Home screen will function as follows:

- The indicator will display **System Enabled** when the system has received a remote “heartbeat” Ethernet signal.

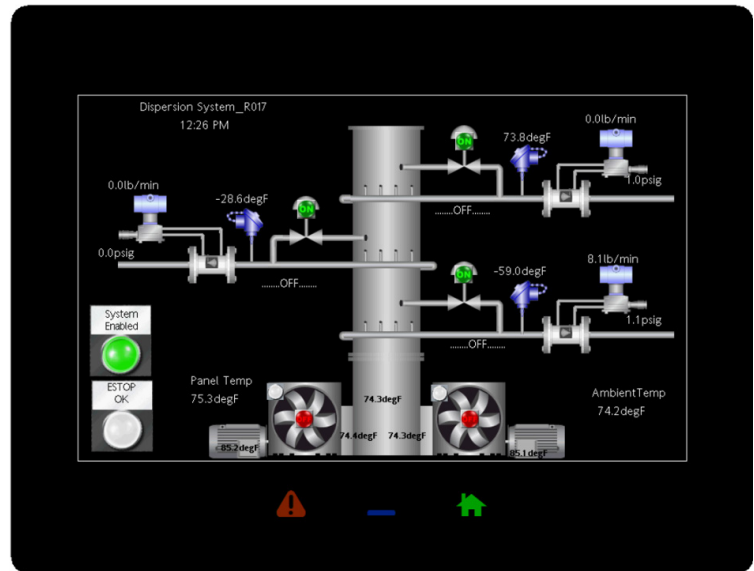

- The indicator will display **System Disabled** when the system has not received a remote “heartbeat” Ethernet signal.

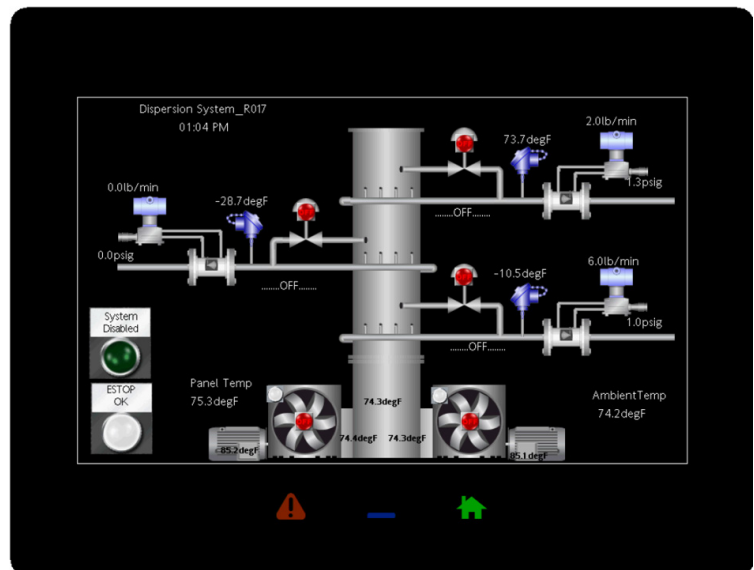

Note: Refer to [Appendix E – PLC IP Configuration](#) for the PLC IP Address, Tag Descriptions, Modbus Addresses, etc.

Appendix A – P&ID

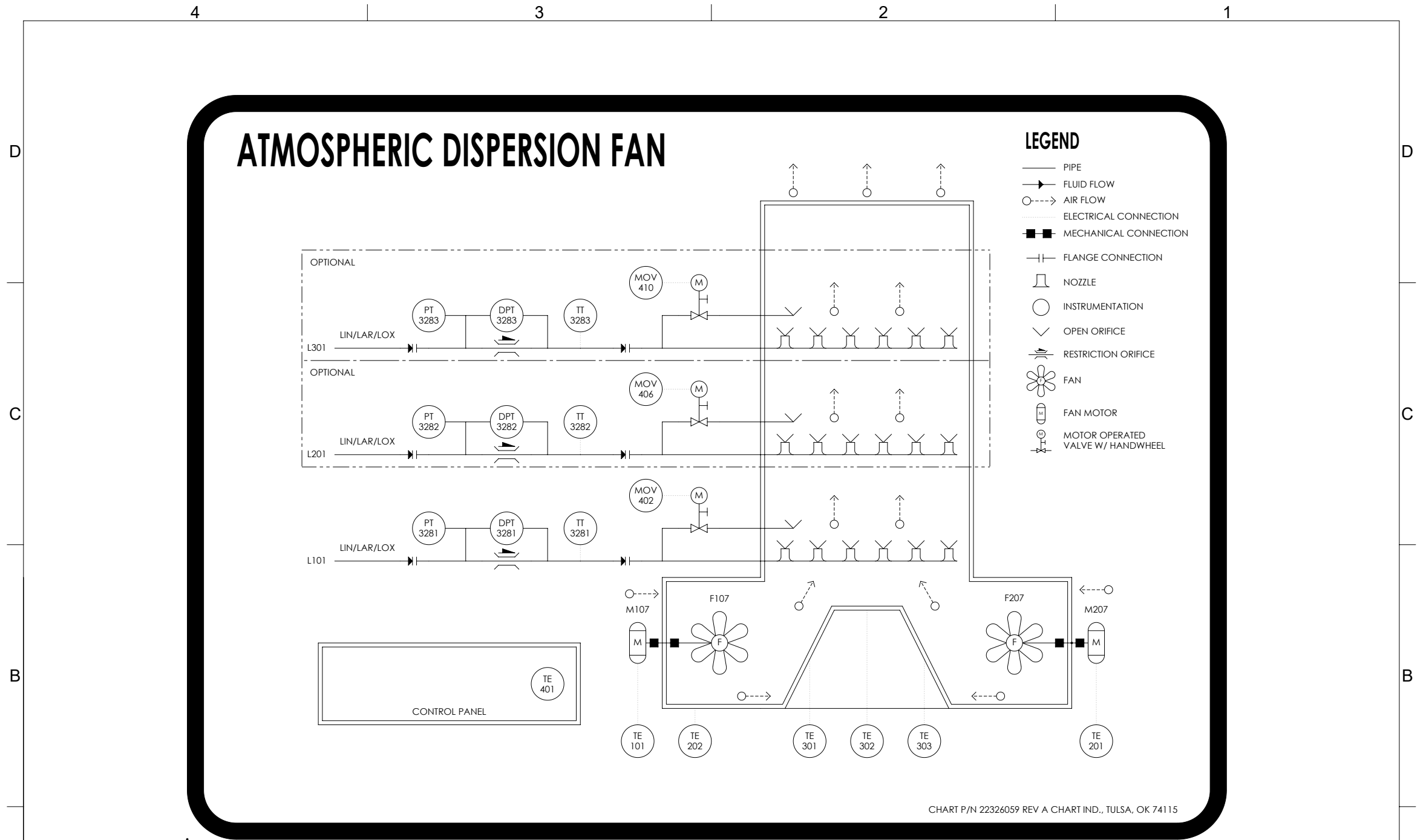





CHART INC.	DRAWN BY	AR	2/5/2025	THIRD ANGLE PROJECTION 	UNLESS SPECIFIED DIMENSIONS ARE INCHES, ANGLES ARE DEGREES, WEIGHT IS LBS. TOLERANCES: FRACTIONS: ± 1/8 ANGLES: ± 1 2 DECIMALS: ± .03 3 DECIMALS: ± .015 WEIGHT: ± 10%	TITLE		
	CHECKED BY	EF	2/11/2025			P&ID ATM DISPERSION FAN 3 RING ADS60000LB/HRTWIN 480V		
THE MATERIAL AND INFORMATION, INCLUDING THE PRINCIPLES OF DESIGN CONTAINED IN THIS PRINT, IS THE EXCLUSIVE PROPERTY OF CHART INC., AND IS CONFIDENTIAL AND PROPRIETARY INFORMATION. THIS INFORMATION MAY NOT BE REPRODUCED, COPIED, OR LOANED IN PART OR IN WHOLE, NOR IS THE INFORMATION TO BE RELATED TO ANY PARTY WITHOUT CHART'S WRITTEN CONSENT.	PROJ ENG	LT	2/11/2025	NOTE REFERENCE 	PART NUMBER			
	MATERIAL REQUIRED				22326059			
					SIZE	DRAWING NUMBER	REVISION	
				SCALE	ESTIMATED WEIGHT	SHEET		
				1:1	C-22326059-A	A		
						1 OF 2		

4		3		2		1	
TAG DEFINITION		CHART #	VENDOR #				
DPT3281	TRANSMITTER, DIFFERENTIAL PRESSURE	22226450	YOKOGAWA #EJX110A-JHS5G-717NN/V1U1/D3/K6				
DPT3282	TRANSMITTER, DIFFERENTIAL PRESSURE	22226450	YOKOGAWA #EJX110A-JHS5G-717NN/V1U1/D3/K6				
DPT3283	TRANSMITTER, DIFFERENTIAL PRESSURE	22226450	YOKOGAWA #EJX110A-JHS5G-717NN/V1U1/D3/K6				
F107	AXIAL FAN BLADE ASM	22327426	HUDSON #CP3000K-5K-9				
F207	AXIAL FAN BLADE ASM	22327426	HUDSON #CP3000K-5K-9				
M107	FAN MOTOR	22327427	SIEMENS #1LE23214AD212AA3				
M207	FAN MOTOR	22327427	SIEMENS #1LE23214AD212AA3				
MOV402	MOTOR OPERATED VALVE	22209271	HABONIM #15FC47W666MAAG/BW-BS ABZ #5350029200 NOAH #SR05				
MOV406	MOTOR OPERATED VALVE	22209271	HABONIM #15FC47W666MAAG/BW-BS ABZ #5350029200 NOAH #SR05				
MOV410	MOTOR OPERATED VALVE	22209271	HABONIM #15FC47W666MAAG/BW-BS ABZ #5350029200 NOAH #SR05				
PT3281	TRANSMITTER, GAUGE PRESSURE	22226451	YOKOGAWA #EJX530A-JBS4N-017NN/V1U1/D3/K6				
PT3282	TRANSMITTER, GAUGE PRESSURE	22226451	YOKOGAWA #EJX530A-JBS4N-017NN/V1U1/D3/K6				
PT3283	TRANSMITTER, GAUGE PRESSURE	22226451	YOKOGAWA #EJX530A-JBS4N-017NN/V1U1/D3/K6				
TE101	THERMOCOUPLE	22226446	PYROMATION #TRB1U-F3B360-2				
TE201	THERMOCOUPLE	22226446	PYROMATION #TRB1U-F3B360-2				
TE202	THERMOCOUPLE	22226446	PYROMATION #TRB1U-F3B360-2				
TE301	THERMOCOUPLE	22226446	PYROMATION #TRB1U-F3B360-2				
TE302	THERMOCOUPLE	22226446	PYROMATION #TRB1U-F3B360-2				
TE303	THERMOCOUPLE	22226446	PYROMATION #TRB1U-F3B360-2				
TE304	THERMOCOUPLE	22226446	PYROMATION #TRB1U-F3B360-2				
TT3281	RTD, RESISTANCE TEMPERATURE DETECTOR	20870323	BURNS #200A10B14S035				
TT3282	RTD, RESISTANCE TEMPERATURE DETECTOR	20870323	BURNS #200A10B14S035				
TT3283	RTD, RESISTANCE TEMPERATURE DETECTOR	20870323	BURNS #200A10B14S035				

 <p>THE MATERIAL AND INFORMATION, INCLUDING THE PRINCIPLES OF DESIGN CONTAINED IN THIS PRINT, IS THE EXCLUSIVE PROPERTY OF CHART INC., AND IS CONFIDENTIAL AND PROPRIETARY INFORMATION. THIS INFORMATION MAY NOT BE REPRODUCED, COPIED, OR LOANED IN PART OR IN WHOLE, NOR IS THE INFORMATION TO BE RELATED TO ANY PARTY WITHOUT CHART'S WRITTEN CONSENT.</p>	DRAWN BY AR 2/5/2025	CHECKED BY EF 2/11/2025	PROJ ENG LT 2/11/2025	THIRD ANGLE PROJECTION  NOTE REFERENCE 	UNLESS SPECIFIED DIMENSIONS ARE INCHES, ANGLES ARE DEGREES, WEIGHT IS LBS. TOLERANCES: FRACTIONS: ± 1/8 ANGLES: ± 1 2 DECIMALS: ± .03 3 DECIMALS: ± .015 WEIGHT: ± 10%	TITLE P&ID ATM DISPERSION FAN 3 RING ADS60000LB/HRTWIN 480V
	MATERIAL REQUIRED					PART NUMBER 22326059
	SIZE C	DRAWING NUMBER C-22326059-A	REVISION A	ESTIMATED WEIGHT	SHEET 2 OF 2	SCALE 1:1

Appendix B – Component I/O Manuals

HUDSON
Products Corporation

Tuf-Lite III[®] Fans
3000K Series Hub

INSTALLATION MANUAL



Adjustable Pitch Fan Assembly 5' thru 15' Diameter

Hudson Tuf-Lite III[®] fan blades

Hudson Tuf-Lite III[®] (White) fan blades are of single piece fiberglass reinforced plastic (FRP) construction optimized for performance, reliability, noise, and cost effectiveness. Tuf-Lite III[®] fan blades are constructed of light weight, corrosion resistant, fiberglass reinforced vinyl-ester resin, with materials, thickness, and processes determined from finite element analysis modeling. Tuf-Edge[®] leading edge erosion and UV protection is a standard with this blade.

The individually balanced blades can be replaced independently - matched sets are not required.

This is a new manual showing the latest Hudson fan line. This fan line includes 5 ft - 15 ft diameter and blade counts from 4 - 15 inclusive. For the original Series 3000 fans in the 6 ft - 14 ft diameter range having 4 - 9 blades, the hubs are identical to the original 3000H family, which means that the K blades can be used to replace the H blades in those fans - if all blades are changed at one time. For those new fans outside this core family, different hub and seal disc sizes are utilized, as shown in the Parts List on Page 7 of 9. This same list shows the original fans highlighted.

RECOMMENDED TOOLS

- Long T-Handle Allen Wrench Set (3/16" to 3/8")
- Medium Size Flat Head Screw Driver
- Brass Ball Peen Hammer
- Flat Bastard File
- 240 Grit Sand Paper
- Anti-Seize Lubricant
- WD-40
- 12" Crescent Wrench
- Shop Towels
- Exact-A-Pitch® Digital Protractor (P/N 62375)
- 25 ft. Measuring Tape
- Pencil or Marker
- Open/Box End Wrench Set (1/2" – 1-1/2")
- Socket Set for 1/2" Drive (1/2" – 1-1/2")
- Torque Wrench(s) Rated for 0-200 ft-lb

INSTALLATION PROCEDURES

ASSEMBLY WITH BUSHING

Clean all mating surfaces between hub, bushing and shaft. All grease and lubricant should be removed, leaving the mating surfaces dry.

If there is no shoulder on shaft to prevent bushing from sliding down shaft, slide spacer/sleeve (not provided) on shaft before bushing. Slide bushing and key onto shaft until flush with end of shaft. The shaft size determines the bushing type (Q2 or R2). Lock bushing on shaft by tightening the set screw in flange with an Allen Wrench. (Note: Q2 bushings have no set screws.) Line up key and set hub on bushing. Engage the three (3) cap screws in flange of bushing into hub spool, using a torque wrench with a socket, and tighten evenly. Use the following table to determine the proper tools and torque values. Cap screw(s) for retainer plate are not required for bushing application.

Bushing Size	Allen Wrench Size	Cap Screw Size	Socket Size	Torque (ft-lb) Dry
Q2	-	3/8"	9/16"	29
R2	3/16"	3/8"	9/16"	29

ASSEMBLY WITH STRAIGHT SHAFT (NO BUSHING)

Clean all mating surfaces between the hub and the shaft. If there is no shoulder on shaft to prevent hub from sliding down shaft, slide spacer/sleeve (not provided) on shaft before hub. Install key in shaft. Line up key and keyway and set hub on shaft. Tighten set screw(s) in hub.

ASSEMBLY WITH TAPERED SHAFT (NO BUSHING REQUIRED)

Clean all mating surfaces between the hub and shaft. Align keyways and install hub. Install retainer plate and cap screw(s) with lock washer(s). Shaft size determines what size cap screw is necessary. Using a torque wrench with a socket, evenly tighten cap screw to recommended standard per table below.

Cap Screw Size	Socket Size	Torque Value (ft-lb)	
		Lubricated	Dry
5/8" NC	15/16"	80	90
3/4" NC	1-1/8"	100	110
1" NC	1-1/2"	150	160

NOTE: Retaining arrangement varies with gear shaft design.

SEAL DISC HARDWARE INSTALLATION

*Seal disc mounting hardware must be installed BEFORE installing blades and blade clamps, due to limited working space.

For 6' to 10' Dia. Fan Assemblies:

Install seal disc spacer as shown in Figure 1 and 2. Install 3/8" bolts on the top hub plate with the threaded portion pointing upwards. Place spacer on bolt, then flat washer, lock washer, and then tighten 3/8" NC nut to recommended standard of 15 ft-lb (lubricated) or 20 ft-lb (dry).

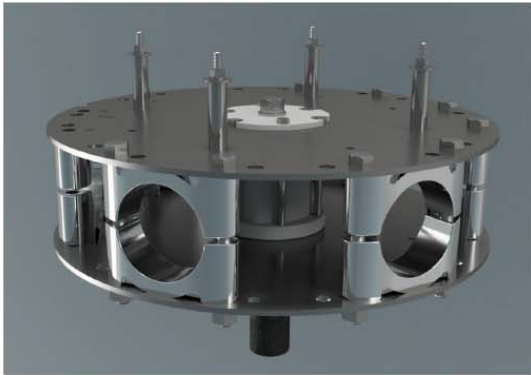

Figure 1

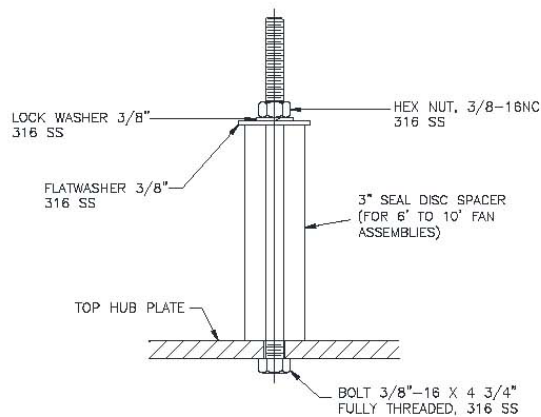

Figure 2

BLADE INSTALLATION

To prevent installation problems, work on one blade at a time. Remove blade clamp bolts, nuts, lock washers, and blade clamp halves from hub. Discard the plastic shipping spacers between the upper and lower blade clamp halves. Assemble blade clamp halves over groove in blade neck, and install into hub (See Figure 3). The thick leading edge will be to your left and thin trailing edge will be to your right as you stand at end of blade.



Figure 3

Install clamp bolts through hub plates and blade clamp, putting bolt heads on top, lock washers and nuts on bottom (See Figure 4). Tighten lightly.

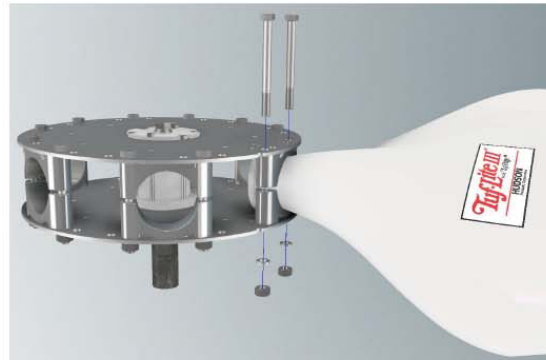

Figure 4

SET PITCH AND TRACK

Use Hudson's EXACT-A-PITCH® digital protractor (See Figure 5) or a bubble protractor to set blade pitch. Mount protractor on a flat bar as a base and place it approximately 1" from tip of blade. Note pitch on protractor. Rotate fan 360°, noting high and low pitch readings. Locate place where pitch reading is at mid-point between high and low readings, and set pitch at that point.



Figure 5

Rotate blade in clamp until digital protractor shows specified pitch angle to within $\pm 0.2^\circ$. Fan pitch angle is shown on fan specification sheet for design duty. After desired pitch angle is set, raise and lower end of fan blade and find midpoint of blade travel. Hold blade at the mid-point. Pull blade outward so that the blade neck flange rests against the back of the blade clamps. Push blade to the right to remove all slack.

Use torque wrench to tighten clamp bolts to 65 ft-lb (lubricated) or 80 ft-lb (dry). Re-check pitch setting. Blade must be set within $\pm 0.2^\circ$ of desired pitch angle. Tighten clamp bolts evenly. **DO NOT OVER-TORQUE CLAMP BOLTS.**

When bolts are tightened, hold a pencil against top end of blade and mark the level onto a fixed object, such as a pole or the fan ring.

Install remaining blades at same place as first blade, following the instructions above. After tightening bolts, mark top end of each blade in the same place first blade was marked. If marks differ by more than 1/2", adjust blade.

CHECK TRACK

After fan is installed in fan stack cylinder ring, outline the top side of each blade onto fan stack cylinder ring with a marker (See Figure 6). The difference between levels of highest and lowest outlines should not be more than 1/2". Correct blade track by loosening clamp bolts and adjusting blade to match track of other blades. Re-tighten bolts and re-check track and pitch angle setting. Re-tighten blade clamp bolts to recommended standard of 65 ft-lb (lubricated) or 80 ft-lb (dry) torque.

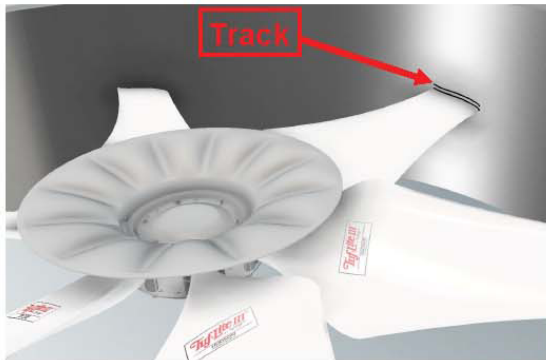

Figure 6

CHECK SWEEP

Measure the distance from trailing edge at blade tip of one blade to trailing edge at blade tip of the adjacent blade (See Figure 7). This distance should be within 1/2" of each other for all successive blades. Correct blade sweep by loosening clamp bolts and adjusting blade to match sweeping of other blades. Re-tighten bolts and re-check sweep and pitch angle setting. Re-tighten blade clamp bolts to recommended standard of 65 ft-lb (lubricated) or 80 ft-lb (dry) torque.



Figure 7

SEAL DISC INSTALLATION

Install 4, 5 or 6 seal disc bolts supplied to mount seal disc to hub, per bolt pattern on seal disc as shown in Figure 8.

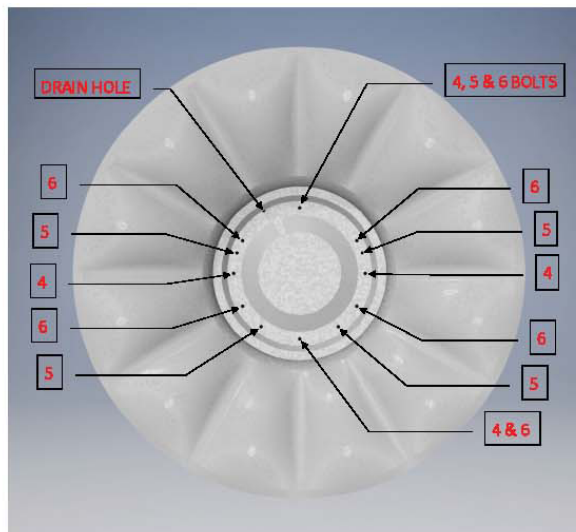

Figure 8

For 4 to 9 Blades

Fasten seal disc to top of hub with four (4) 3/8" cap screws, as shown in Figures 9. See Figure 10 for 5' fans, Figure 11 for 6' to 10' fans, and Figure 12 for 11' to 12' fans. Tighten to recommended standard of 15 ft-lb (lubricated) or 20 ft-lb (dry).



Figure 9

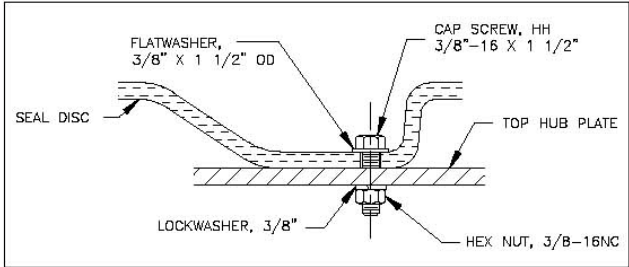

Figure 12: For 11' to 15' Dia. Fan Assemblies

For 10 to 15 Blades:

Install 3/8" NC bolts at six (6) places on top hub plate (See Figure 13 & 14). Threaded portion of bolts must be pointing up to mount seal disc. Install lock washer, nut, and flat washer on each bolt. Tighten 3/8" NC nuts to 15 ft-lb (lubricated) and 20 ft-lb (dry).

Locate the six (6) mounting holes in seal disc and install over the six (6) bolts pointing up on upper hub plate. If difficulty is encountered, loosen bolts on seal flanges until seal disc can be mounted, then re-tighten to 15 ft-lb (lubricated) or 20 ft-lb (dry).

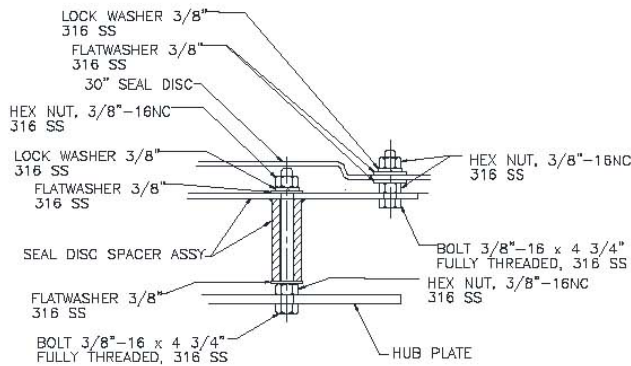

Figure 10: For 5' Dia. Fan Assemblies

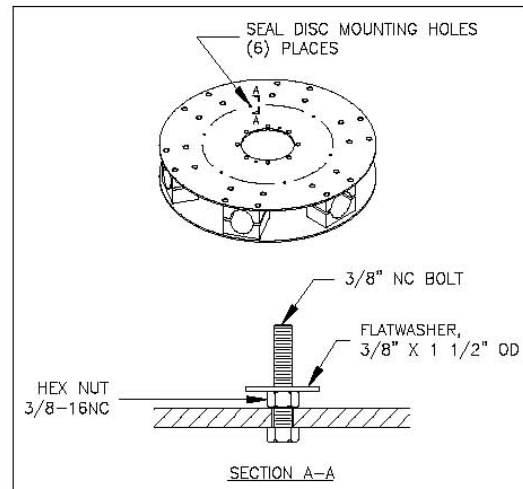

Figure 13

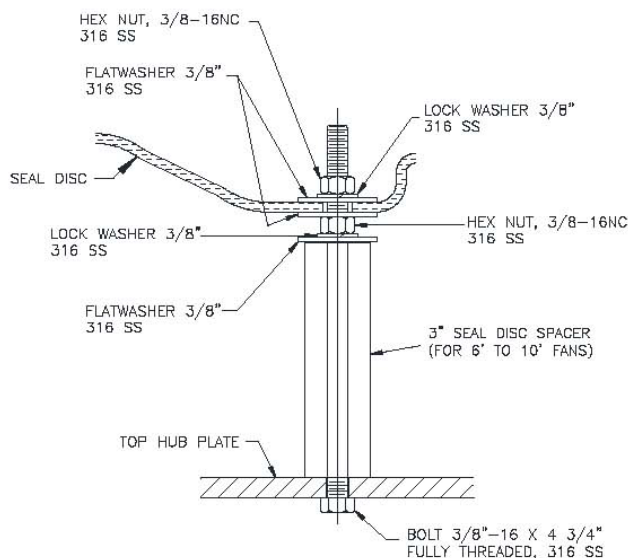

Figure 11: For 6' to 10' Dia. Fan Assemblies

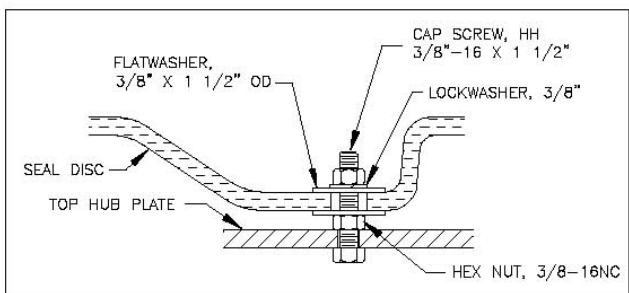

Figure 14

NOTE: The purpose of the seal disc is to prevent hot air from recirculating back down through the hub, increasing efficiency.

CHECKING TIP CLEARANCE

Rotate fan in position inside fan ring or fan stack to check tip clearance (See Figure 15). The recommended tip clearance is shown in the table below. Check for spots where fan blade clearance is not within the recommended tolerance.

Fan Diameter	Minimum	Maximum
5' through 9'	1/4"	1/2"
>9' through 11'	1/4"	5/8"
>11' through 14'	1/4"	3/4"

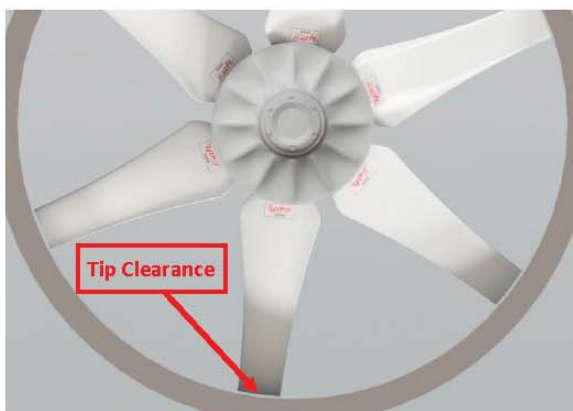

Figure 15

If necessary, adjust fan ring or fan stack by shimming to obtain proper clearance. For heat exchangers, spacers may be added at the fan ring joints to increase clearance (See Figure 16). Use a chisel to maintain the correct gap until the bolts on the ring are re-tightened.



Figure 16

If a small adjustment is needed, tighten or loosen nut on fan strut in section requiring adjustment (See Figure 17).



Figure 17

OPERATING INSTRUCTIONS

Start fan and check rotation. Viewed from top (discharge), fan blades should rotate clockwise.

Hudson recommends to re-verify the blade clamp torque after the initial 10-15 minutes of cold operation (i.e., the fan doesn't need to be exposed to the working temperature of the process). This will ensure that the blades are settled within the clamps after the centrifugal forces have acted.

Check motor power consumption to be sure fan is pulling desired load. **CAUTION:** If positive pitch is set in summer to use all available motor amps (nameplate rating), motor could be overloaded in winter. Design pitch angles usually do not use all of the available motor horsepower. This ensures that the motors will not be overloaded at low winter temperatures.

For the fans that have remained idle (such as a shutdown or turn-around), it is highly recommended to re-verify the torque on the blade clamps before putting it back into operation.

For heat exchanger applications, we recommend using Hudson bearings part number: 50081 (top bearing) and 50082 (bottom bearing).



Figure 18

OPERATIONAL LIMITS

Temperature: -100F to 220F Continuous,
250F Intermittent

Wind speed: 75 mph, shutdown fan if forecast is higher

Parts List
HUDSON PRODUCTS CORPORATION
Adjustable Pitch Fan Assembly 5' Thru 15' Diameter
Series 3000K HUB

ITEM	DESCRIPTION	TYPE	PART NO.	NO. OF BLADES											
				4	5	6	7	8	9	10	11	12	13	14	15
	1" Diameter Thru 2.62" Diameter Shaft	Q-2	5K Hub Assy. No. Part No.	3104HM7 79200	3105HM7 79202	3106HM7 79204	3107H H3710	3108H H3810	3109H H3910						
			6K-10K Hub Assy. No. Part No.	3104H H3410	3105H H3510	3106H H3610	3107H H3710	3108H H3810	3109H H3910						
			11K-14K Hub Assy. No. Part No.	3104H H3410	3105H H3510	3106H H3610	3107H H3710	3108H H3810	3109H H3910	3110H 79210	3111H 79212	3112H 79214	3113H 79216	3114H 79218	3115H 79220
			15K Hub Assy. No. Part No.	3104HP12 79222	3105HP12 79224	3106HP12 79226	3107HP12 79228	3108HP12 79230	3109HP12 79232	3110HP12 79234	3111HP12 79236	3112HP12 79238	3113HP12 79240	3114HP12 79242	3115HP12 79244
	2.68" Diameter Thru 3.62" Diameter Shaft	R-2	5K Hub Assy. No. Part No.	3204HM7 79201	3205HM7 79203	3206HM7 79205	3207H H3720	3208H H3820	3209H H3920						
			6K-10K Hub Assy. No. Part No.	3204H H3420	3205H H3520	3206H H3620	3207H H3720	3208H H3820	3209H H3920						
			11K-14K Hub Assy. No. Part No.	3204H H3420	3205H H3520	3206H H3620	3207H H3720	3208H H3820	3209H H3920	3210H 79211	3211H 79213	3212H 79215	3213H 79217	3214H 79219	3215H 79221
			15K Hub Assy. No. Part No.	3204HP12 79223	3205HP12 79225	3206HP12 79227	3207HP12 79229	3208HP12 79231	3209HP12 79233	3210HP12 79235	3211HP12 79237	3212HP12 79239	3213HP12 79241	3214HP12 79243	3215HP12 79245
1	Hub Plate (2 Per Hub)	Q-2	5K Part No.	C3394	C3395	C3396	61707	C3216	C3399						
		R-2		C3294	C3295	C3296	61717	C3215	C3299						
		Q-2	6K-10K Part No.	C3216	61705	C3216	61707	C3216	C3399						
		R-2		C3215	61715	C3215	61717	C3215	C3299						
		Q-2	11K-14K Part No.	C3216	61705	C3216	61707	C3216	C3399	C3410	C3411	C3412	C3413	C3414	C3415
		R-2		C3215	61715	C3215	61717	C3215	C3299	C3400	C3401	C3402	C3403	C3404	C3405
		Q-2	15K Part No.	C3578	C3580	C3582	C3584	C3578	C3579	C3580	C3581	C3582	C3583	C3584	C3585
		R-2		C3568	C3570	C3572	C3574	C3568	C3569	C3570	C3571	C3572	C3573	C3574	C3575
ITEM	DESCRIPTION	TYPE	PART NO	QUANTITY PER ASSEMBLY											
2	Hub Spool	Q-2	85101	1	1	1	1	1	1	1	1	1	1	1	
		R-2	85102												
3	Bushing	Q-2	Specify Bore	1	1	1	1	1	1	1	1	1	1	1	
		R-2													
4	Blade Clamp Half, Un-painted Aluminum (Standard)		65003	8	10	12	14	16	18	20	22	24	26	28	30
			65003S												
			65016												
			C3006												
5	Blade Clamp Bolt 5/8"-11 x 7" with Nut (Mech. Galv.)		70701	8	10	12	14	16	18	20	22	24	26	28	30
6	5/8" Lock washer (Mech. Galv.)		73730	8	10	12	14	16	18	20	22	24	26	28	30
7	Stop Plate Sub-Assembly	Q-2	65007	1	1	1	1	1	1	1	1	1	1	1	
		R-2	65008												
8	Stop Plate Bolt 3/4"-10 x 4 1/2" (Zinc Plated)		72427	1	1	1	1	1	1	1	1	1	1	1	
9	3/4" Lock washer (Mech. Galv.)		73738	1	1	1	1	1	1	1	1	1	1	1	
10	3/4" Flat Washer (Mech. Galv.)		73640	1	1	1	1	1	1	1	1	1	1	1	
11	Hub Spool Bolt 3/8"-16 x 7" with Nut (Mech. Galv.)		70700	6	6	6	6	6	6	6	6	6	6	6	
12	3/8" Lock washer (Mech. Galv.)		73723	6	6	6	6	6	6	6	6	6	6	6	
13	Seal Disc Bolt 3/8"-16 X 1 1/2" (316 SS)		60274	4	4	4	4	4	4	6	6	6	6	6	
14	3/8" Flat Washer (316 SS)		73623	4	4	4	4	4	4	12	12	12	12	12	
15	3/8" Lock washer (316 SS)		73722	4	4	4	4	4	4	6	6	6	6	6	
16	3/8" Hex Nut (316 SS)		72050	4	4	4	4	4	4	12	12	12	12	12	
17	30" Dia. Seal Disc w/ Spacer Assy Mounting (5K w/4-8 blades)		81100	1	1	1									
	38" Dia. Seal Disc w/ 3" Spacer (6K w/ 7-9 blades, 6K-10K w/ 4-9 blades)		81105	1	1	1	1	1	1						
	50" Dia. Seal Disc (11K-14K with 4-9 blades)		D3439	1	1	1	1	1	1						
	63" Dia. Seal Disc (11K-14K with 10-12 blades)		81114							1	1	1			
84" Dia. Seal Disc (11K-14K with 13-15 blades and 15K with 4-15 blades)		81115										1	1	1	
18	Tuf-Lite III® Fan Blade (White)		Varies	4	5	6	7	8	9	10	11	12	13	14	15

Highlighting shows original 3000H fans where the new K blades can replace the H blades. Appropriate Seal Disc per above table is recommended. K blades and H blades are interchangeable for this original hub group (if all blades changed at one time).

HUDSON PRODUCTS CORPORATION
Adjustable Pitch Fan Assembly 5' Thru 15' Diameter
Series 3000K HUB

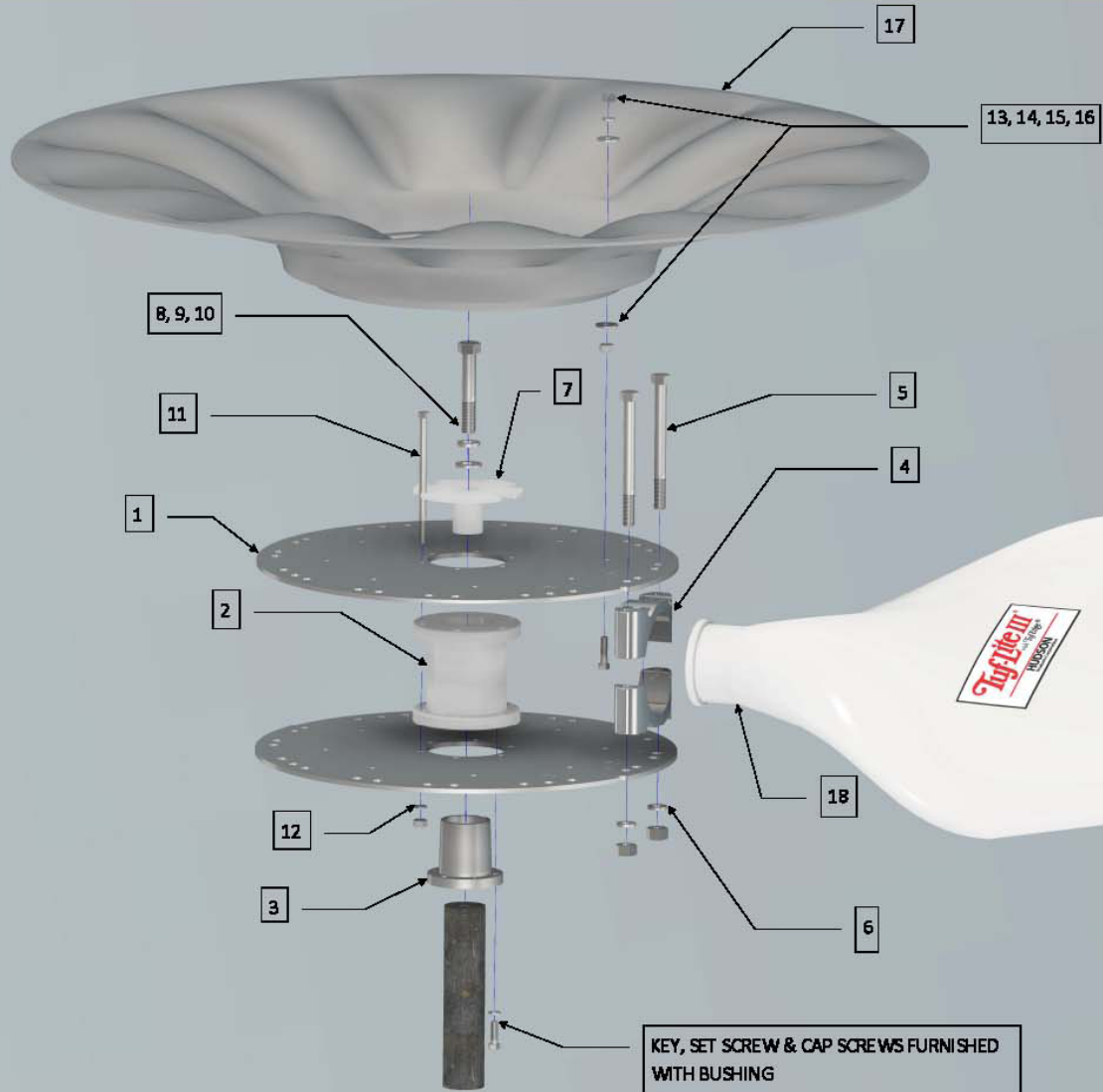

STANDARD MATERIALS & FINISHES

Blades: Fiberglass reinforced vinyl ester
Hub Spool: Ductile Iron, Zinc Rich Coating
Plates: Steel, Galvanized
Bushing: Malleable Iron
Seal Disc: Fiberglass Reinforced Polyester

Blade Clamps:
 Un-painted Aluminum (Standard)
 Epoxy Coated Aluminum (Option 1)
 Epoxy Coated Ductile Iron (Option 2)
 Machined Stainless Steel (Option 3)
Fasteners:
 Steel, Mech. Galvanized & 316 SS Opt.
 Complete Fan with 316 SS (Option 1)
 Complete Fan with K500 Monel (Option 2)

WHEN ORDERING, SPECIFY FAN DIAMETER, TYPE & NUMBER OF BLADES & SHAFT DIAMETER

EXAMPLE: APT — 14K — 6 2 7/8" BORE

Fan Model Fan Diameter & Blade Type Number Shaft Diameter
 Adjustable Pitch (Specify "K" for TuF-Lite III® Blades) of Blades

HUDSON

Products Corporation

99660 Grunwald Rd.
Beasley, Texas 77417-8600
Phone: 281-396-8100
Fax: 281-396-8388
1-800-634-9160 (24 Hours)
[Email: TufLiteorders@hudsonproducts.com](mailto:TufLiteorders@hudsonproducts.com)
<http://www.hudsonproducts.com>

Hudson, Auto-Variable, Combin-Aire, Exact-A-Pitch, Fin-Fan, Heatflo, Hy-Fin, Split-Flo, Sob Aire, Stac-Flo, Steamflo, Thermflo, Tuf-Edge, Tuf-Lite, Tuf-Lite II, and Tuf-Lite III are registered trademarks of Hudson Products Corporation.

©2012 Hudson Products Corp. All Rights Reserved.

User's Manual for eX700 Series Touchscreen Products



eX700 Series

Operating Instructions





Copyright © 2018-2022 Exor International S.p.A. – Verona, Italy
Subject to change without notice

The information contained in this document is provided for informational purposes only. While efforts were made to verify the accuracy of the information contained in this documentation, it is provided "as is" without warranty of any kind.

Third-party brands and names are the property of their respective owners.
www.exorint.com

Software available in these products is based on OpenSource. Visit oss.exorint.net for more details.

MANUGENEX7xx - Version 2.13
© 2018-2022 EXOR International S.p.A. - Subject to change without notice



Table of Contents

Introduction	4
Safety Guide	5
1 Product Overview	6
2 Standards and Approvals	7
3 Technical Specifications	9
4 Technical Data	11
4.1 Dimensions	14
4.2 Installation Environment	16
4.3 Safety instruction	17
4.4 Installation Procedure	17
5 Connections	18
5.1 Serial Port	20
5.2 Ethernet Port	20
5.3 Optional plugin module	21
5.4 Optional plugin module identification	22
5.5 Optional plugin module installation procedure	23
6 Power Supply, Grounding and Shielding	26
7 Battery	27
8 Special Instruction for Use	28
9 Getting Started	28
10 Unpacking and Packing Instructions	29



Introduction

The operational guidelines described below is information which relates to the device, installation, transportation, storage, assembly, use and maintenance.

This Operating Instruction describes the main features of the Exor operator panels. The Manual refers to the following models:

- eX705 Operator interface with TFT color 5" widescreen display multitouch projected capacitive touchscreen
- eX707 Operator interface with TFT color 7" widescreen display multitouch projected capacitive touchscreen
- eX710 Operator interface with TFT color 10.1" widescreen display multitouch projected capacitive touchscreen
- eX712 Operator interface with TFT color 12.3" widescreen display multitouch projected capacitive touchscreen
- eX715 Operator interface with TFT color 15.6" widescreen display multitouch projected capacitive touchscreen
- eX721 Operator interface with TFT color 21.5" widescreen display multitouch projected capacitive touchscreen

- eX707G Operator interface with high-brightness TFT color 7" widescreen display multitouch projected capacitive touchscreen
- eX710G Operator interface with high-brightness TFT color 10.1" widescreen display multitouch projected capacitive touchscreen



Safety Guide

The manual contains safety standards that must be respected for the personal safety and to avoid damage. Indications of attention are divided into three levels of severity:

DANGER: indicates a failure to observe safety rules and such failure may cause death or serious injuries.



DANGER

ATTENTION: indicates a failure to observe safety rules and that deficiency may cause damage.

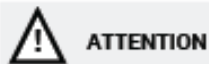

ATTENTION

CAUTION: indicates a failure to observe safety rules and that deficiency may cause defects to the equipment or inconsistencies.



CAUTION



1 Product Overview

eX Series 700 HMI products combine state-of-the-art connectivity features and top performance in a great design. Products have been designed as IoT edge devices with the combination of a powerful controller with networking capability (up to 3 Ethernet networks) and outstanding communication options including client/server OPC UA. They are the ideal choice for all demanding IoT edge applications in factory, marine and building automation.

The glass projected capacitive touchscreen and the brilliant displays with size up to 21.5" and resolution up to 1920x1080 guarantee great optical performance; with the support of multitouch gesture programming they can create the most natural human interfaces.

eX700G Series combine high-performance sunlight-readable display with state-of-the-art connectivity features and top performance in a great design maintaining as a design commitment the fact that the product is likely to be used in environments where the safety of operators is at risk. The glass projected capacitive touchscreen and the display are bonded to guarantee the highest optical performance and resistance in such environments.

- eX Series 700 products have been designed to run the JMobile software for powerful HMI applications.
- Gateway function with OPC UA Server and Client.
- Secure connectivity with JMcloud and full network separation.
- Powerful browser with industry standard Web engines.
- Optional CODESYS V3 PLC runtime with choice of major I/O protocols.
- Optional plug-in modules for fieldbus systems, I/O and controllers.



2 Standards and Approvals

The products have been designed for use in an industrial environment in compliance with the 2014/30/EU EMC Directive.

The products have been designed in compliance with:

EN 61000-6-4 CISPR 22 Class A
 CISPR 16-2-3

EN 61000-6-2 EN 61000-4-2
 EN 61000-4-3
 EN 61000-4-4
 EN 61000-4-5
 EN 61000-4-6
 EN 61000-4-8
 EN 61000-4-11
 EN 61000-4-29

 EN60945

IECEX
IEC 60079-0
IEC 60079-7
IEC 60079-31

IECEX: IECEX ULD 17.0019X
Ex ec IIC T5...T4 Gc -20°C≤Tamb≤+60°C or 0°C≤Tamb≤+50°C
Ex tc IIIC T95°C Dc

ATEX
EN 60079-0
EN 60079-7+A1
CENELEC 60079-31

DEMKO 17 ATEX 1871X
 II 3G Ex ec IIC T5...T4 Gc -20°C≤Tamb≤+60°C or 0°C≤Tamb≤+50°C
II 3D Ex tc IIIC T95°C Dc

The installation of these devices into the residential, commercial and light-industrial environments is allowed only in the case that special measures are taken in order to ensure conformity to EN 61000-6-3.

The products are in compliance with the Restrictions on Certain Hazardous Substances (RoHS) Directive 2011/65/EU

In compliance with the above regulations the products are CE marked.

Products described in this manual may have other approvals and certificates.
Please refer to product datasheets available at www.exorint.com



2 Standards and Approvals

Product Identification

The product may be identified through a plate attached to the rear cover. You will have to know the type of unit you are using for correct usage of the information contained in the guide. An example of this plate is shown in the figure below:

Note: the eX707 label is used as an example for eX700 Series



product model name	eX707
product part number	EX707U5P1
year/week of production	1816
serial number	AA00011FT000000561AA
version id of the product	120408A04002000
manufacturer address	Exor International S.p.A. Via Monte Fiorino 9 IT-37057 San Giovanni Lupatoto (VR)
ATEX Marking	DEMKO 17 ATEX 1871X  II 3G Ex ec IIC T5...T4 Gc 0°C ≤ Tamb ≤ +50°C or -20°C ≤ Tamb ≤ +60°C II 3D Ex tc IIIC T95°C Dc
IECEX Marking	IECEX: IECEX ULD 17.0019X Ex ec IIC T5...T4 Gc 0°C ≤ Tamb ≤ +50°C or -20°C ≤ Tamb ≤ +60°C Ex tc IIIC T95°C Dc



3 Technical Specifications

Touchscreen technology	Projected capacitive	
Back-up battery	3V 50mAh Lithium, rechargeable, not user-replaceable, model VL2330.	
Fuse	Automatic	
Serial Port	RS-232, RS-485, RS-422 software configurable	
Flash	4GB for eX705, eX707, eX710, eX707G, eX710G, 8GB for eX712, eX715, eX721	
RAM	512MB for eX705, 1GB for eX707, eX710, eX707G, eX710G, 2GB for eX712, eX715, eX721	
Hardware clock	Clock/Calendar with back-up battery	
Accuracy RTC (at 25°C)	<100ppm	
<i>Environmental conditions</i>		
Operating temperature (surrounding air temperature)	-20 ÷ +60°C (vertical installation) Plug-in modules and USB devices may limit max temperature to +50°C	EN 60068-2-14
Storage temperature	-20 ÷ +70°C	EN 60068-2-1 EN 60068-2-2 EN 60068-2-14
Operating and storage humidity	5 ÷ 85 % RH not-condensing	EN 60068-2-30
Vibrations	5 ÷ 9 Hz, 7 mm _{pp} 9 ÷ 150 Hz, 1 g	EN 60068-2-6
Shock	± 50 g, 11 ms, 3 pulses per axis	EN 60068-2-27
Protection class	Front panel IP66, Rear IP20	EN 60529
<i>Electromagnetic Compatibility (EMC)</i>		
Radiated disturbance test	Class A	CISPR 22 CISPR 16-2-3
Electrostatic discharge immunity test	8 kV (air electrostatic discharge) 4 kV (contact electrostatic discharge)	EN 61000-4-2
Radiated, radio-frequency, electromagnetic field immunity test	80 MHz ÷ 1 GHz, 10V/m 1,4 GHz ÷ 2 GHz, 3 V/m 2 GHz ÷ 2.7 GHz, 1 V/m	EN 61000-4-3
Burst immunity test	± 1 KV dc power port ± 1 KV signal line	EN 61000-4-4
Surge immunity test	± 0,5 KV dc power port (line to earth) ± 0,5 KV dc power port (line to line) ± 1 KV signal line (line to earth)	EN 61000-4-5
Immunity to conducted disturbances induced by radiofrequency field	0.15 ÷ 80 MHz, 10V	EN 61000-4-6
Power frequency magnetic field immunity test	Enclosure, 50/60Hz, 30A/m	EN 61000-4-8



3 Technical Specifications

Voltage dips, short interruptions and voltage variations immunity test

Port: AC mains; Level:	
100% duration:	1 cycle and 250 cycles (50Hz); 1 cycle and 300 cycles (60Hz);
40% duration:	10 cycles (50Hz); 12 cycles (60Hz);
70% duration:	25 cycles (50Hz); 30 cycles (60Hz);
Phase: 0°-180°	

Test executed on the 230Vac side of the Exor International S.p.A. Power Supply EN 61000-4-11

Port: DC mains; Level:	
0% duration:	10ms 20 spaces by 1s

Test executed on the 24Vdc of the EUT EN 61000-4-29

Durability information

Backlight service life (LED type)

40000 Hrs. or more
(Time of continuous operation until the brightness of the backlight reaches 50% of the rated value when the surrounding air temperature is 25°C) - see Note 1

Note 1: Extended use in environments where the surrounding air temperature is 40°C or higher may degrade backlight quality/reliability/durability.

Surface resistance

Chemical resistance of the front glass for an exposure time of 24 hours without visible changes:

- Betadine (10% Povidone Solution)
- Cola
- Electrode Gel/Paste
- Hydrogen Peroxide (3% Solution)
- NaCl (0.9% Solution)
- Coffee
- Dextrose (5% Glucose Solution)
- Hydrogen chloride (0.5% Solution PH=1)
- Isopropyl Alcohol
- Sodium Hypochlorit
- Ethyl Alcohol (70%-90%)
- Quaternary ammonium compound



4 Technical Data

Model	eX705	eX707	eX710
Display / Backlight	TFT Color / LED	TFT Color / LED	TFT Color / LED
Colors	64K	16M	16M
Resolution	800X480	800X480	1280X800
Diagonal (inches)	5" widescreen	7" widescreen	10.1" widescreen
Dimming	yes	yes	yes
Flash	4GB	4GB	4GB
SD card slot	yes	yes	yes
RAM	512MB	1GB	1GB
Serial Port	RS-232,RS-485, RS-422 software configurable	RS-232,RS-485, RS-422 software configurable	RS-232,RS-485, RS-422 software configurable
Ethernet port	2 10/100Mb	2 10/100Mb, 1 10/100/1000Mb	2 10/100Mb, 1 10/100/1000Mb
USB port	1 Host interface version 2.0 max. 500mA	2 Host interface version 2.0 max. 500mA	2 Host interface version 2.0 max. 500mA
Expansion slot	1 Optional Plugin	2 Optional Plugin	2 Optional Plugin
Battery	rechargeable	rechargeable	rechargeable
Real Time Clock	yes	yes	yes
Voltage	24Vdc (*)	24Vdc (*)	24Vdc (*)
Current rating (at 24VDC)	0.6A	0.7A	1.00A
Weight	1 Kg	1.3 Kg	1.7 Kg

(*) 10-32Vdc

For applications requiring compliance with EN 61131-2 and specifically in reference to 10 ms voltage dips (according to EN 61000-4-29), the lower power supply voltage limit is 20,4Vdc.



4 Technical Data

Model	eX712	eX715	eX721
Display / Backlight	TFT Color / LED	TFT Color / LED	TFT Color / LED
Colors	16M	16M	16M
Resolution	1920x720	1366X768	1920X1080
Diagonal (inches)	12,3" widescreen	15.6" widescreen	21.5" widescreen
Dimming	yes	yes	yes
Flash	8GB	8GB	8GB
SD card slot	yes	yes	yes
RAM	2GB	2GB	2GB
Serial Port	RS-232, RS-485, RS-422 software configurable	RS-232,RS-485, RS-422 software configurable	RS-232,RS-485, RS-422 software configurable
Ethernet port	2 10/100Mb, 1 10/100/1000Mb	2 10/100Mb, 1 10/100/1000Mb	2 10/100Mb, 1 10/100/1000Mb
USB port	2 Host interface version 2.0 max. 500mA	2 Host interface version 2.0 max. 500mA	2 Host interface version 2.0 max. 500mA
Expansion slot	2 Optional Plugin	2 Optional Plugin	2 Optional Plugin
Battery	rechargeable	rechargeable	rechargeable
Real Time Clock	yes	yes	yes
Voltage	24Vdc (*)	24Vdc (*)	24Vdc (*)
Current rating (at 24VDC)	1.10A	1.20A	1.70A
Weight	1.8 Kg	4.1 Kg	6.1 Kg

(*) 10-32Vdc

For applications requiring compliance with EN 61131-2 and specifically in reference to 10 ms voltage dips (according to EN 61000-4-29), the lower power supply voltage limit is 20,4Vdc.



4 Technical Data

Model	eX707G	eX710G
Display / Backlight	High-brightness TFT Color with optical bonding/ LED	High-brightness TFT Color with optical bonding/ LED
Colors	16M	16M
Resolution	800X480	1280X800
Diagonal (inches)	7" widescreen	10.1" widescreen
Dimming	yes	yes
Flash	4GB	4GB
SD card slot	yes	yes
RAM	1GB	1GB
Serial Port	RS-232,RS-485, RS-422 software configurable	RS-232,RS-485, RS-422 software configurable
Ethernet port	2 10/100Mb, 1 10/100/1000Mb	2 10/100Mb, 1 10/100/1000Mb
USB port	2 Host interface version 2.0 max. 500mA	2 Host interface version 2.0 max. 500mA
Expansion slot	2 Optional Plugin	2 Optional Plugin
Battery	rechargeable	rechargeable
Real Time Clock	yes	yes
Voltage	24Vdc (*)	24Vdc (*)
Current rating (at 24VDC)	0.7A	1.00A
Weight	1.3 Kg	1.7 Kg

(*) 10-32Vdc

For applications requiring compliance with EN 61131-2 and specifically in reference to 10 ms voltage dips (according to EN 61000-4-29), the lower power supply voltage limit is 20,4Vdc.



4 Technical Data

4.1 Dimensions

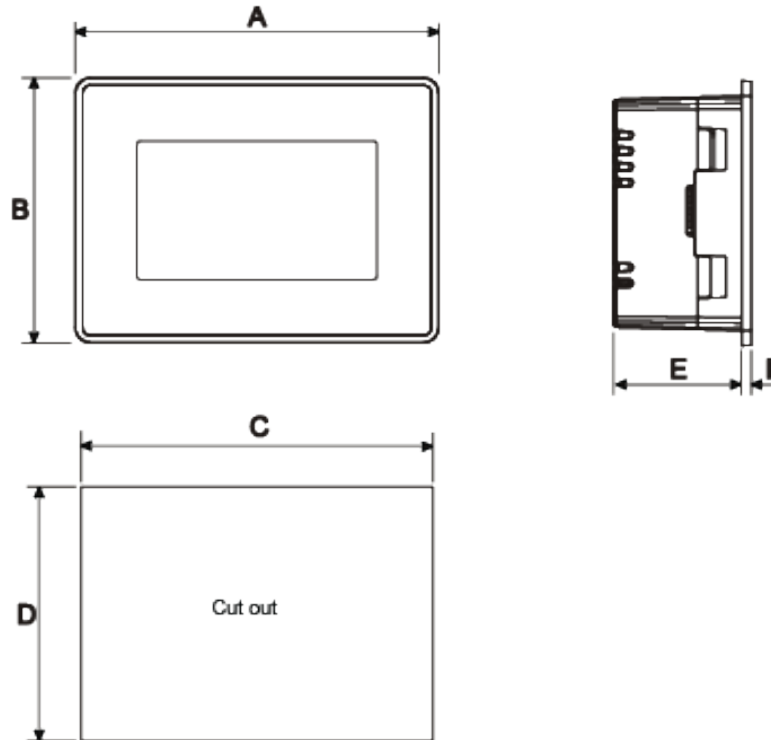

MODEL	A	B	C	D	E	F
eX705	147mm/5.78"	107mm/4.21"	136mm/5.35"	96mm/3.78"	56mm/2.40"	8mm/0.31"



4 Technical Data

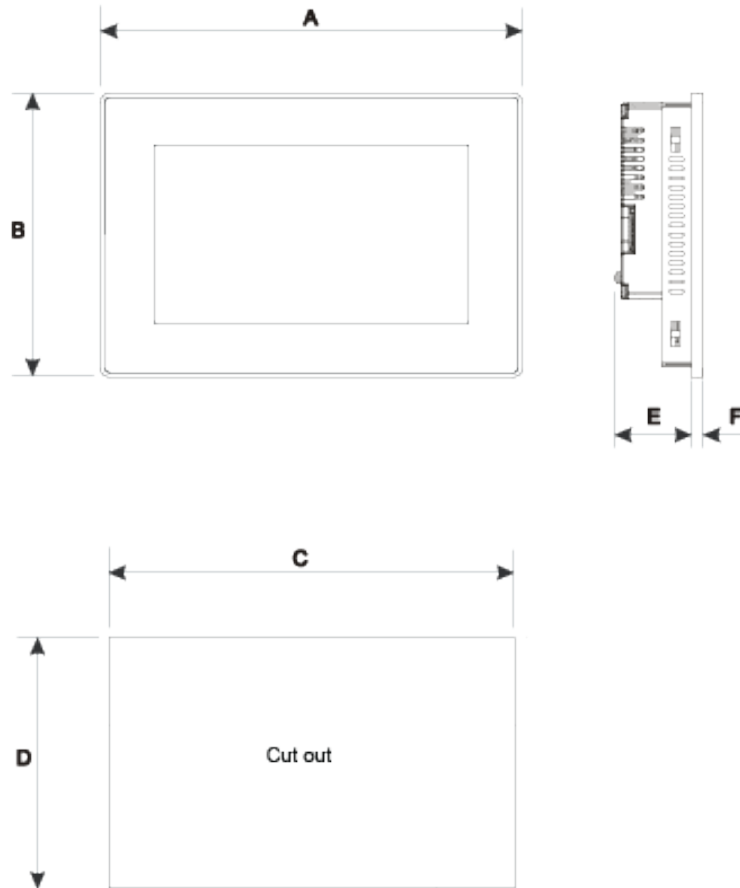

MODEL	A	B	C	D	E	F
eX707/eX707G	187mm/7.36"	147mm/5.79"	176mm/6.90"	136mm/5.35"	47mm/1.85"	8mm/0.31"
eX710/eX710G	282mm/11.10"	197mm/7.80"	271mm/10.67"	186mm/7.32"	56mm/2.20"	8mm/0.31"
eX712	344,5mm/13.55"	163mm/6.41"	332,5mm/13,09"	163mm/6,41"	49mm/1,92"	8mm/0,31"
eX715	422mm/16.60"	267mm/10.50"	411mm/16.18"	256mm/10.00"	56mm/2.20"	8mm/0.31"
eX721	552mm/21.73"	347mm/13.66"	541mm/21.30"	336mm/13.22"	56mm/2.20"	8mm/0.31"



4 Technical Data

4.2 Installation Environment

Avoid prolonged exposition to direct sunlight to avoid the risk of overheating the device.

The equipment is not intended for installation in contact with corrosive chemical compounds. Check the resistance of the front panel to a specific compound before installation.

Do not use tools of any kind (screwdrivers, etc.) to operate the touch screen of the panel.

In order to meet the front panel protection classifications, proper installation procedure must be followed:

- the borders of the cutout must be flat
- screw up each fixing screw until the bezel corner get in contact with the panel.
- the cutout for the panel must be of the dimensions indicated in this manual.

The IP66 is guaranteed only if:

- max deviation from the plane surface to the cut-out: $\leq 0.5\text{mm}$
- thickness of the case where is mounted the equipment: from 1,5mm to 6mm
- max surface roughness where the gasket is applied: $\leq 120\ \mu\text{m}$

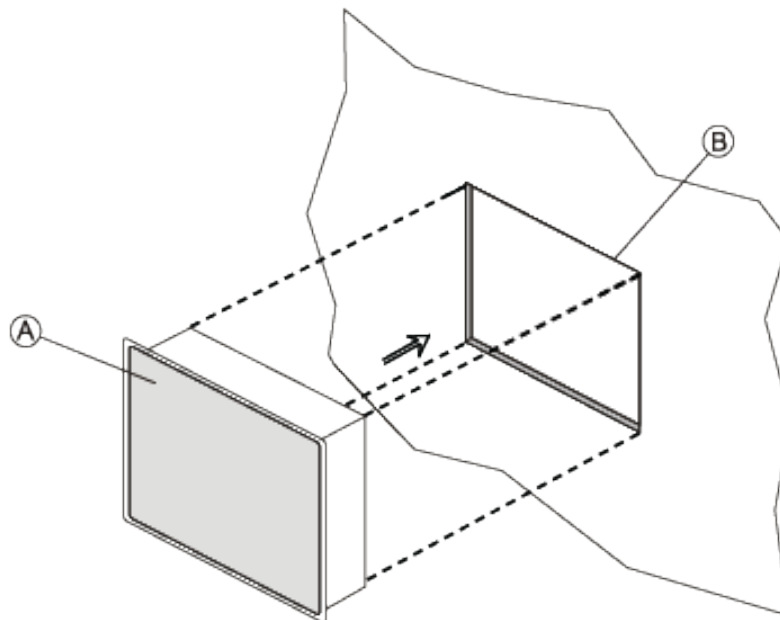

A. eX7xx
B. Installation cut-out



4 Technical Data

4.3 Safety instruction



For all installation notes, please refer to the Installation Guide provided with the product.

4.4 Installation Procedure

Place the fixing brackets contained in the fixing kit as shown in figure

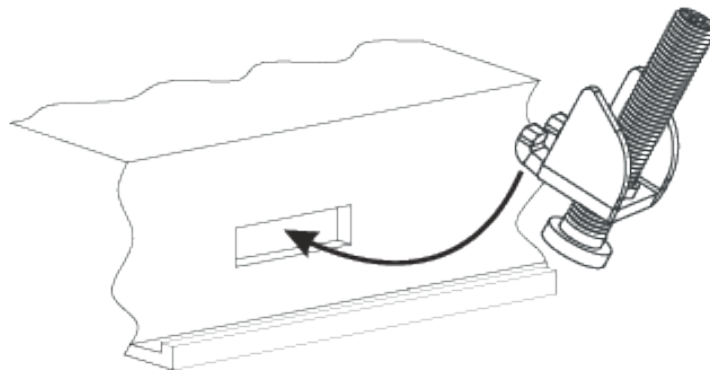

CAUTION

Tightening torque: 130Ncm or screw each fixing screw until the bezel corner gets in contact with the panel.



5 Connections

eX705

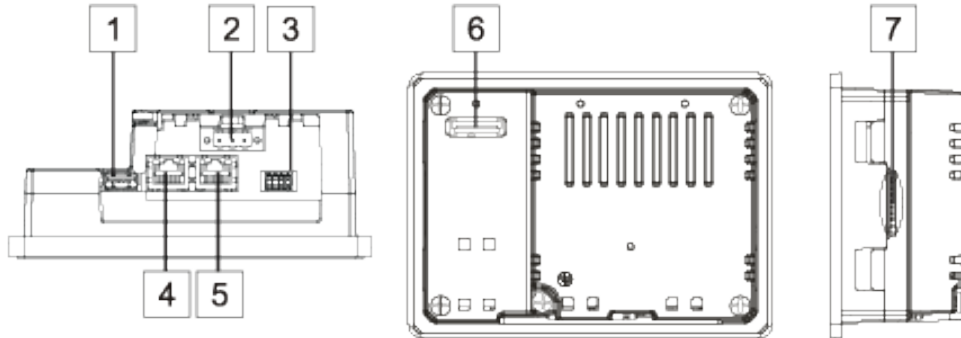

Fig. 5.1

1. USB Port V2.0, max. 500 mA - for maintenance only
2. Power Supply
3. Serial port
4. Ethernet Port 0 (10/100Mb)
5. Ethernet Port 1 (10/100Mb)
6. Expansion slot for Plugin module
7. SD Card Slot



5 Connections

eX707, eX707G, eX710, eX710G, eX712, eX715, eX721

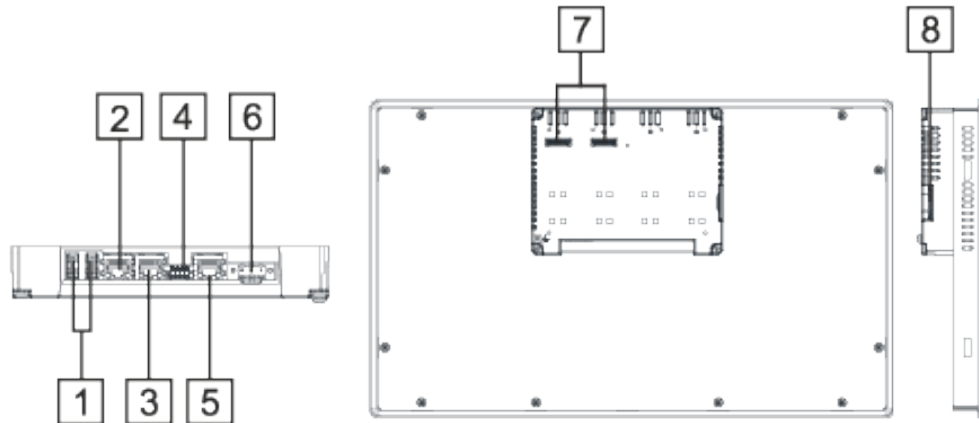

Fig. 5.2

1. USB Port V2.0, max. 500 mA - for maintenance only
2. Ethernet port 2 (10/100Mb)
3. Ethernet port 1 (10/100Mb)
4. Serial Port
5. Ethernet port 0 (10/100/1000Mb)
6. Power Supply
7. 2x Expansion slot for Plugin module
8. SD Card Slot



5 Connections

5.1 Serial Port

The serial port is used to communicate with the PLC or with another type of controller. Different electrical standards are available for the signals in the PLC port connector: RS-232, RS-422, RS-485.

The serial port is software programmable. Make sure you select the appropriate interface in the programming software.

SERIAL PORT		RS-232	RS-422, RS-485
Pin	Description	Pin	Description
1	RX	1	CHB-
2	TX	2	CHA-
3	CTS	3	CHB+
4	RTS	4	CHA+
5	+5V output	5	+5V output
6	GND	6	GND
7		7	
8	SHIELD	8	SHIELD

To operate in RS-485 pins 1-2 and 3-4 must be connected externally.

The communication cable must be chosen for the type of device being connected.

5.2 Ethernet Port

The Ethernet port have two status indicators. Please see description in figure.

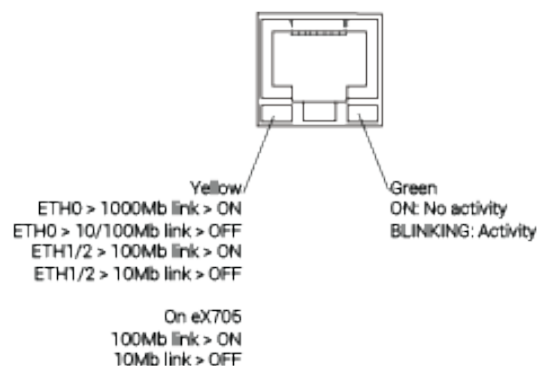



5 Connections

5.3 Optional plugin module

eX Series 700 panels have several optional plugin module, multiple modules configurations are possible.

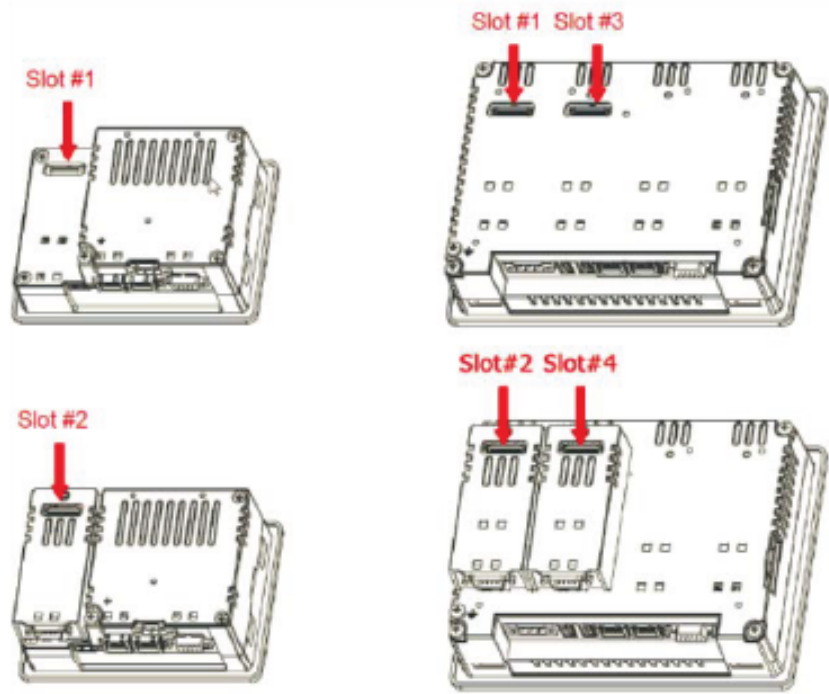

Slot#2 and Slot#4 are available only if plugin module has the "bus extension connector".

Each slot carries three communication channels:

- 1 serial interface
- 1 CAN interface
- 1 SPI interface
- 1 2G/3G interface

Note: It is not possible to stack two modules that are using the same type of interface.



5 Connections

5.4 Optional plugin module identification

Note: the PLCM01 label is used as an example for PLCM01, PLCM05, PLCM09X, PLI003



product model name	PLCM01
product part number	PLCM01U0P1
year/week of production	1816
serial number	AA0000225000000561AA
version id of the product	050100A000000000
manufacturer address	Exor International S.p.A. Via Monte Fiorino 9 IT-37057 San Giovanni Lupatoto (VR)



5 Connections

5.5 Optional plugin module installation procedure

PLCM

PLI003

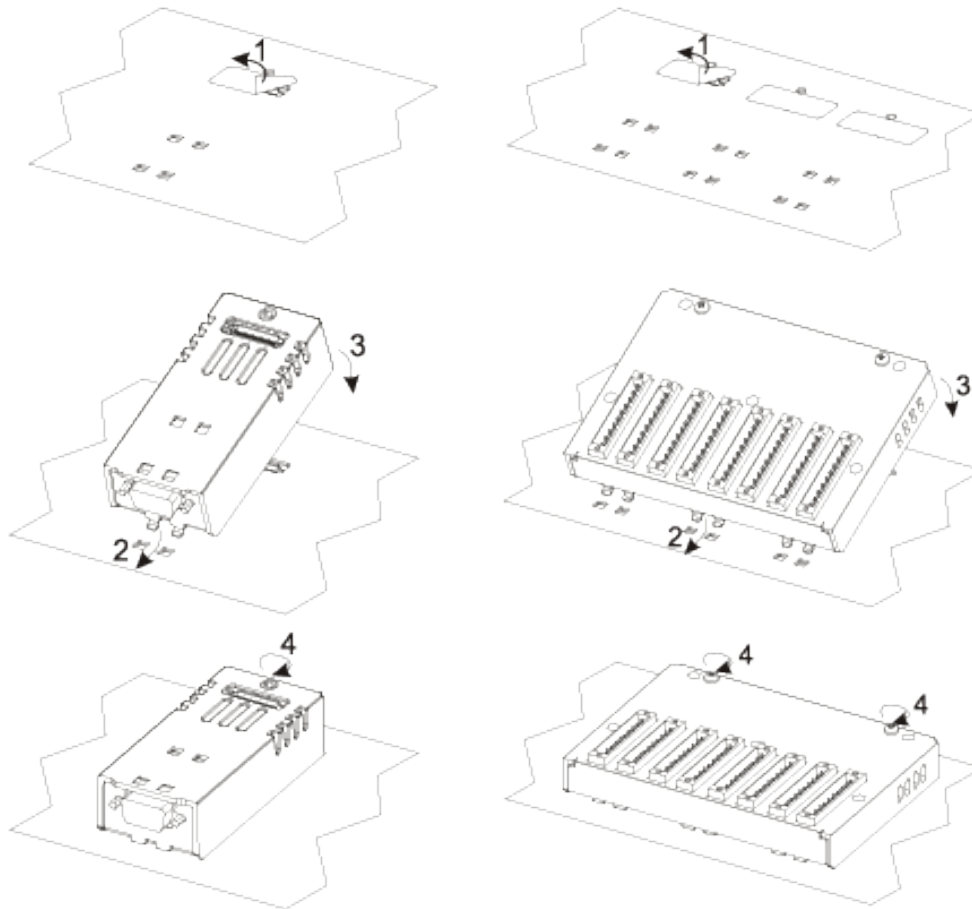



5 Connections

Below you can find relation between modules ATEX and IECEx certified and max number of modules that can be used into eX700 serie panels, based on their Interface Type:

Module	Application	Max Modules	Interface Type	Bus Extension connector
PLCM01	CAN	1 for eX705 2 for other panels	CAN	Y
PLCM01-NE	CAN	1 for eX705 2 for other panels	CAN	N
PLCM05	CODESYS License	1		Y
PLCM09X	3G modem	1		Y
PLIO03	Multifunction I/O	1	SPI	N

PLCM01 / PLCM01-NE: Operating temperature -20°C to 60°C
 PLCM05: Operating temperature -20°C to 60°C
 PLCM09X: Operating temperature -20°C to 60°C
 PLIO03: with part number PLIO03:xxxxY where:
 - Y≤2 is operating temperature range 0°C≤Tamb≤+50°C with Operating Temperature Code T5 (vertical installation), 12-30VDC
 - Y>2 is operating temperature range -20°C≤Tamb≤+60°C with Operating Temperature Code T4 (vertical installation), 12-30VDC



Note the above different "Operating Temperature Code" for different part number of PLIO03 module.

PLCM and PLIO03 electrical ratings:

- PLCM01: For electrical rating refers to the host eX700 models.
- PLCM05: For electrical rating refers to the host eX700 models and PLIO03 ratings
- PLCM09X: 2xDigital Inputs voltage 12÷30 Vdc, 3mA; 2xDigital Outputs voltage 12÷30 Vdc, 0.5A
- PLIO03: 20xDigital Inputs voltage 12÷30 Vdc; 12xDigital Outputs voltage 12÷30 Vdc, 0.5A; 4xAnalog inputs 0÷10 Vdc, 4-20mA; 4xAnalog outputs: 0÷10 Vdc, 4-20mA



5 Connections

Below you can find relation between modules and max number of modules that can be used into eX series 700 panels, based on their Interface Type:

Module	Application	Max Modules	Interface Type	Bus Extension connector
PLCM02	KNX	1	Serial	N
PLCM03	Serial RS232	2	Serial	Y
PLCM04	Serial RS485	2	Serial	Y
PLCM06	Profibus DP	1	SPI	N
PLCM07	Ethernet	1	Ethernet	N
PLI006	Compact I/O	2	SPI	N

Max modules refers to max number of modules can be plugged into the HMI (all slots).

If you are planning to use PLCM03 and PLCM04 (additional serial ports) you will obtain following "COM - Slot#" association:

- a module plugged in Slot#1 or into Slot#2 will be COM2,
- a module plugged in Slot#3 or into Slot#4 will be COM3.

If you are planning to use two PLCM01 (CAN interface) you will obtain following Slot# association:

- a module plugged in Slot#1 or into Slot#2 will be the CanPort 0,
- a module plugged in Slot#3 or into Slot#4 will be the CanPort 1.



6 Power Supply, Grounding and Shielding

The power supply terminal block is shown in the figure below.

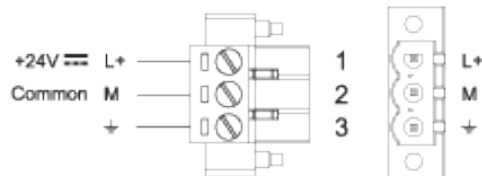

Fig. 6.1

3 conductor 1,5mmq wire size minimum, minimum temperature conductor rating 105°C.

Note: Ensure that the power supply has enough power capacity for the operation of the equipment.

The unit must always be grounded to earth with 1,5mmq wire size minimum. Grounding helps limit the effects of noise due to electromagnetic interference on the control system.

Earth connection will have to be done using either the screw or the faston terminal located near the power supply terminal block. A label helps identify the ground connection. Also connect to ground the terminal 3 on the power supply terminal block.

The power supply circuit may be floating or grounded. In the latter case, connect to ground the power source common as shown in figure (see below) with a dashed line.

When using the floating power scheme, note that the panel internally connects the power common to ground with a 1MΩ resistor in parallel with a 4,7nF capacitor.

The power supply must have double or reinforced insulation.

The suggested wiring for the power supply is shown below.

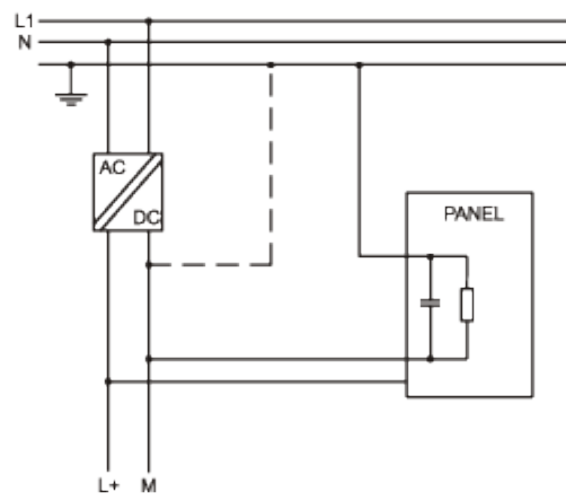

Fig. 6.2

All the electronic devices in the control system must be properly grounded. Grounding must be performed according to applicable regulations.



7 Battery

These devices are equipped with rechargeable Lithium battery, not user-replaceable.

The following information is maintained by the battery:

- hardware real-time clock (date and time)

Charge:

At first installation must be charged for 48 hours.

When the battery is fully charged, it ensures a period of 3 months of data back-up at 25°C.

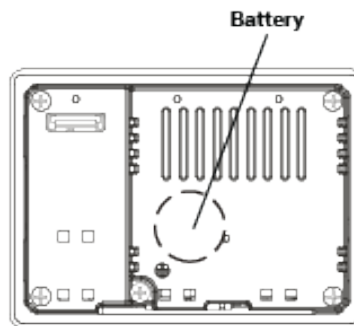

Fig. 7.1: eX705

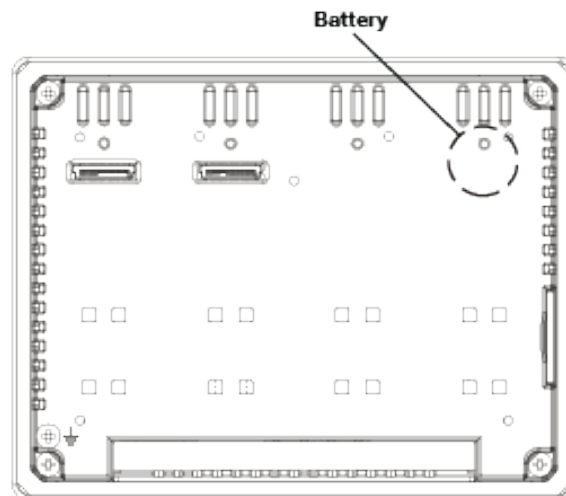

Fig. 7.2: eX707, eX707G, eX710, eX710G, eX712, eX715, eX721



ATTENTION

Dispose of batteries according to local regulations.



ATTENTION

This device cannot be disposed of as a domestic waste but according to WEEE European Directive 2012/19/EU





8 Special Instruction for Use

- The equipment shall only be used in an area of not more than pollution degree 2, as defined in IEC/EN 60664-1.
- The equipment shall be installed in an enclosure that provides a degree of protection not less than IP 54 in accordance with IEC/EN 60079-15.
- Transient protection shall be provided that is set at a level not exceeding 140 % of the peak rated voltage value at the supply terminals to the equipment.
- Install the HMI device according to the accompanying installation instructions.
- Ground the HMI device according to the accompanying installation instructions.
- Only qualified personnel may install the HMI device or repair it.
- Ensure that the aeration holes are not covered.
- Care shall be taken not to allow layers of dust to form on the graphic panel in a way that might cause the accumulation of static charges. Keep the faceplate of the HMI device clean: the equipment must be cleaned only with a soft cloth and neutral soap product. Do not use solvents.
- This device should not be used for purposes and methods other than indicated in this document and in the documentation accompanying the product.

9 Getting Started

eX Series 700 HMI products delivery configuration is based on a loader. Use the services of the loader to install applications on the device such as JMobile runtime or browsers. JMobile Studio version V2.6 or higher is required. JMo-bile Studio is a software tool that must be properly installed on a computer running Microsoft Windows.

There are two options to transfer a JMobile application project to a HMI device:

- | | |
|----------|---|
| Ethernet | Connect the HMI device to the computer with an Ethernet network. In JMobile Studio select the command Run/Download to target. You may have to ensure that the proper firewall policy has been configured in the computer to allow JMobile Studio to access the network. |
| USB | Create an Update Package using JMobile Studio and copy it to a USB Flash drive. |

Updated product documentation is available at www.exorint.com.

For the products described in this manual please check:

- Systems Settings User Manual
- JMobile Studio User Manual



10 Unpacking and Packing Instructions

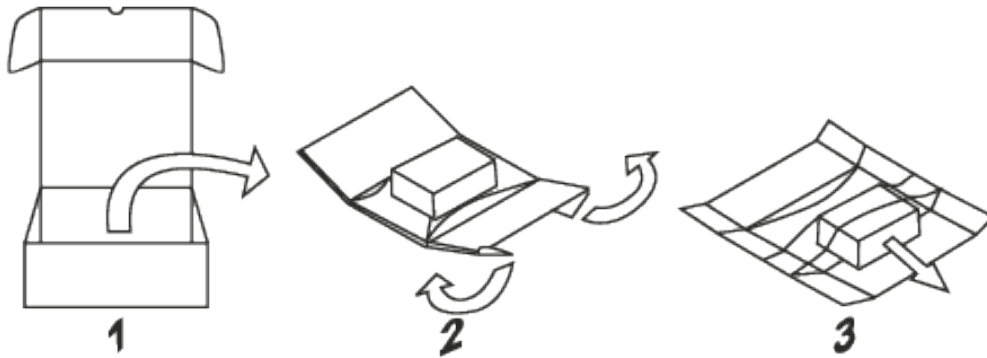

Fig. 11.1: eX705, eX707, eX707G, eX710, eX710G, eX712

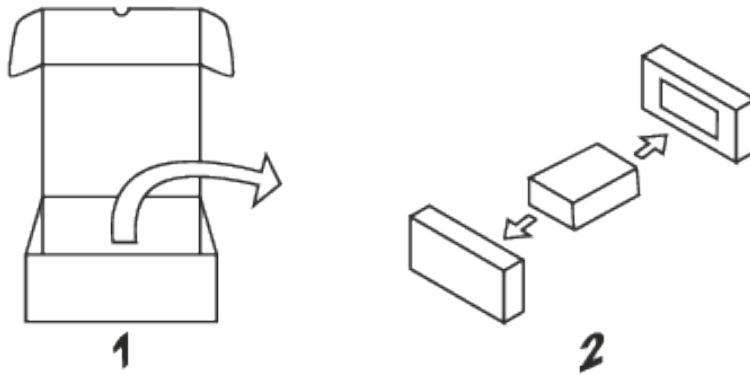

Fig. 11.2: eX715, eX721

To repack the unit, please follow the instructions backwards.

REV	DATE	BY	CHK	APP'D	DESCRIPTION
1	10/20/21	DAK/JIA			ORIGINAL ISSUE
2	10/20/21	DAK/JIA			UPDATES TO PARTS LIST
3	10/20/21	DAK/JIA			UPDATES TO PARTS LIST
4	10/20/21	DAK/JIA			CUSTOMER REQUESTED UPDATES AS CONSTRUCTED
5	10/20/21	DAK/JIA			BILL OF MATERIALS CORRECTION
6					

ISSUED BY	DATE	TITLE
DAK/JIA	10/20/21	CRYOGENIC DISPERSION SYSTEM
APPROVED	DATE	SYMBOL SHEET
JIA	10/22/21	CLIENT NAME
DESIGNED BY	DATE	CLIENT NAME
DAK/JIA	10/22/21	CLIENT NAME
PROJECT NUMBER	21781372	DRAWING NUMBER
21781372-000A-04wg		21781372-00A
		SHEET
		000A

CONDUCTORS	MOTORS	PUSHBUTTONS	SWITCHES	HEATER CONTROLS
<p>CONDUCTOR</p> <p>CONDUCTORS NOT CONNECTED</p> <p>CONDUCTORS CONNECTED</p> <p>CONDUCTOR SHIELD</p> <p>FIELD CONDUCTOR</p> <p>EARTH GROUND</p> <p>CHASSIS GROUND</p> <p>SHIELD GROUND ISOLATED IF REQUIRED BY SPECS</p> <p>TERMINALS</p> <p>STANDARD TERMINAL BLOCK</p> <p>KNIFE-BLADE TERMINAL BLOCK</p>	<p>SINGLE PHASE MOTOR</p> <p>DC MOTOR</p> <p>AC MOTOR FOR DRIVES</p> <p>3 PHASE MOTOR</p> <p>MOTOR STARTER</p> <p>MOTOR STARTER WITH TERMINAL NUMBERS</p> <p>FORWARD MOTOR STARTER WITH TERMINAL NUMBERS</p> <p>REVERSE MOTOR STARTER WITH TERMINAL NUMBERS</p>	<p>NORMALLY OPEN PUSHBUTTON</p> <p>NORMALLY CLOSED PUSHBUTTON</p> <p>EMERGENCY STOP PUSHBUTTON</p> <p>NORMALLY OPEN PUSHBUTTON WITH LIGHT</p> <p>NORMALLY CLOSED PUSHBUTTON WITH LIGHT</p> <p>PUSHBUTTON LIGHT</p> <p>SWITCHES</p> <p>NORMALLY OPEN SELECTOR SWITCH</p> <p>NORMALLY CLOSED SELECTOR SWITCH</p> <p>CONTACT MADE IN POS1</p> <p>NORMALLY CLOSED SELECTOR SWITCH</p> <p>CONTACT MADE IN POS2</p>	<p>NORMALLY OPEN FLOW SWITCH</p> <p>NORMALLY CLOSED FLOW SWITCH</p> <p>NORMALLY OPEN LEVEL SWITCH</p> <p>NORMALLY CLOSED LEVEL SWITCH</p> <p>NORMALLY OPEN TEMPERATURE SWITCH</p> <p>NORMALLY CLOSED TEMPERATURE SWITCH</p> <p>NORMALLY OPEN LIMIT SWITCH</p> <p>NORMALLY CLOSED LIMIT SWITCH</p> <p>HELD OPEN LIMIT SWITCH</p> <p>HELD CLOSED LIMIT SWITCH</p>	<p>SINGLE PHASE HEATER</p> <p>SOLID STATE RELAY</p> <p>THERMOCOUPLE</p> <p>TRANSFORMERS</p> <p>TRANSFORMER 2 PR1/2 SEC</p> <p>TRANSFORMER 4 PR1/4 SEC</p> <p>TRANSFORMER 2 PR1/4 SEC</p> <p>CURRENT TRANSFORMER</p>
<p>RELAY COILS AND CONTACTS</p> <p>CONTROL RELAY</p> <p>CONTROL RELAY WITH TERMINAL NUMBERS</p> <p>POWER CONTACTOR</p> <p>POWER CONTACTOR WITH TERMINAL NUMBERS</p> <p>EMERGENCY STOP RELAY</p> <p>EMERGENCY STOP RELAY WITH TERMINAL NUMBERS</p> <p>NORMALLY DREWED CONTACT</p> <p>NORMALLY CLOSED CONTACT</p> <p>NORMALLY OPEN CONTACT WITH TERMINAL NUMBERS</p> <p>NORMALLY CLOSED CONTACT WITH TERMINAL NUMBERS</p> <p>SOLENOIDS</p> <p>SOLENOID VALVE</p> <p>SOLENOID STANDARD</p>	<p>ON/OFF DELAY COIL</p> <p>ON/OFF DELAY COIL WITH TERMINAL NUMBERS</p> <p>ON DELAY CONTACT</p> <p>ON DELAY CONTACT WITH TERMINAL NUMBERS</p> <p>NORMALLY OPEN ON DELAY CONTACT</p> <p>NORMALLY CLOSED OFF DELAY CONTACT</p> <p>NORMALLY CLOSED OFF DELAY CONTACT WITH TERMINAL NUMBERS</p> <p>TIMER COIL</p> <p>TIMER COIL WITH TERMINAL NUMBERS</p> <p>LIGHTS</p> <p>PILOT LIGHT</p> <p>PRESS TO TEST PILOT LIGHT</p> <p>PANEL LIGHT</p>	<p>ALARMS</p> <p>ALARM BELL</p> <p>Buzzer</p> <p>ALARM HORN</p> <p>CIRCUIT BREAKERS AND DISCONNECTS</p> <p>CIRCUIT BREAKER</p> <p>THERMAL CIRCUIT BREAKER</p> <p>DISCONNECT</p> <p>FUSED DISCONNECT SWITCH</p> <p>FUSED DISCONNECT</p> <p>FUSES</p> <p>FUSED TERMINAL</p> <p>FUSE</p>	<p>ALARMS</p> <p>ALARM BELL</p> <p>Buzzer</p> <p>ALARM HORN</p> <p>CIRCUIT BREAKERS AND DISCONNECTS</p> <p>CIRCUIT BREAKER</p> <p>THERMAL CIRCUIT BREAKER</p> <p>DISCONNECT</p> <p>FUSED DISCONNECT SWITCH</p> <p>FUSED DISCONNECT</p> <p>FUSES</p> <p>FUSED TERMINAL</p> <p>FUSE</p>	<p>HEATER CONTROLS</p> <p>SINGLE PHASE HEATER</p> <p>SOLID STATE RELAY</p> <p>THERMOCOUPLE</p> <p>TRANSFORMERS</p> <p>TRANSFORMER 2 PR1/2 SEC</p> <p>TRANSFORMER 4 PR1/4 SEC</p> <p>TRANSFORMER 2 PR1/4 SEC</p> <p>CURRENT TRANSFORMER</p>



BW SYSTEMS INC.
2180 Highway 100, Suite 101, 101-101-101

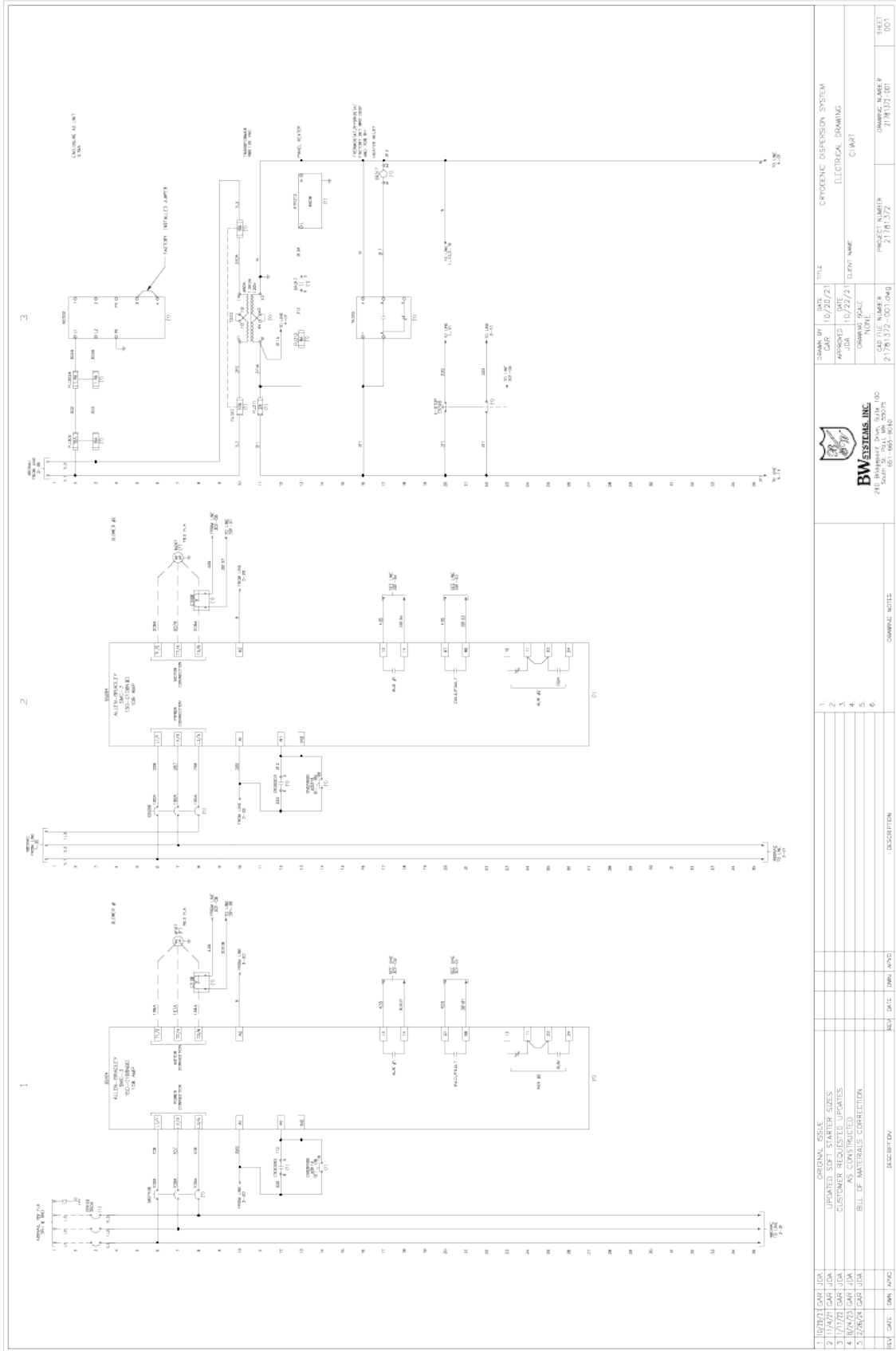

BW SYSTEMS INC
4150 W. 11th St., Suite 100
Denver, CO 80202
(303) 751-9548

REV.	DATE	BY	DATE	DESCRIPTION
1				ORIGINAL ISSUE
2				UPDATED SOFT STARTER SIZES
3				CUSTOMER REQUESTED UPDATES
4				BILL OF MATERIALS CORRECTION
5				BILL OF MATERIALS CORRECTION
6				BILL OF MATERIALS CORRECTION

NO.	DATE	BY	DATE	DESCRIPTION
1				ORIGINAL ISSUE
2				UPDATED SOFT STARTER SIZES
3				CUSTOMER REQUESTED UPDATES
4				BILL OF MATERIALS CORRECTION
5				BILL OF MATERIALS CORRECTION
6				BILL OF MATERIALS CORRECTION

CRYOGENIC DISPERSION SYSTEM
ELECTRICAL DRAWING
CIRCUIT
DRAWING NUMBER: 21781372-001
DRAWING NAME: 21781372-001

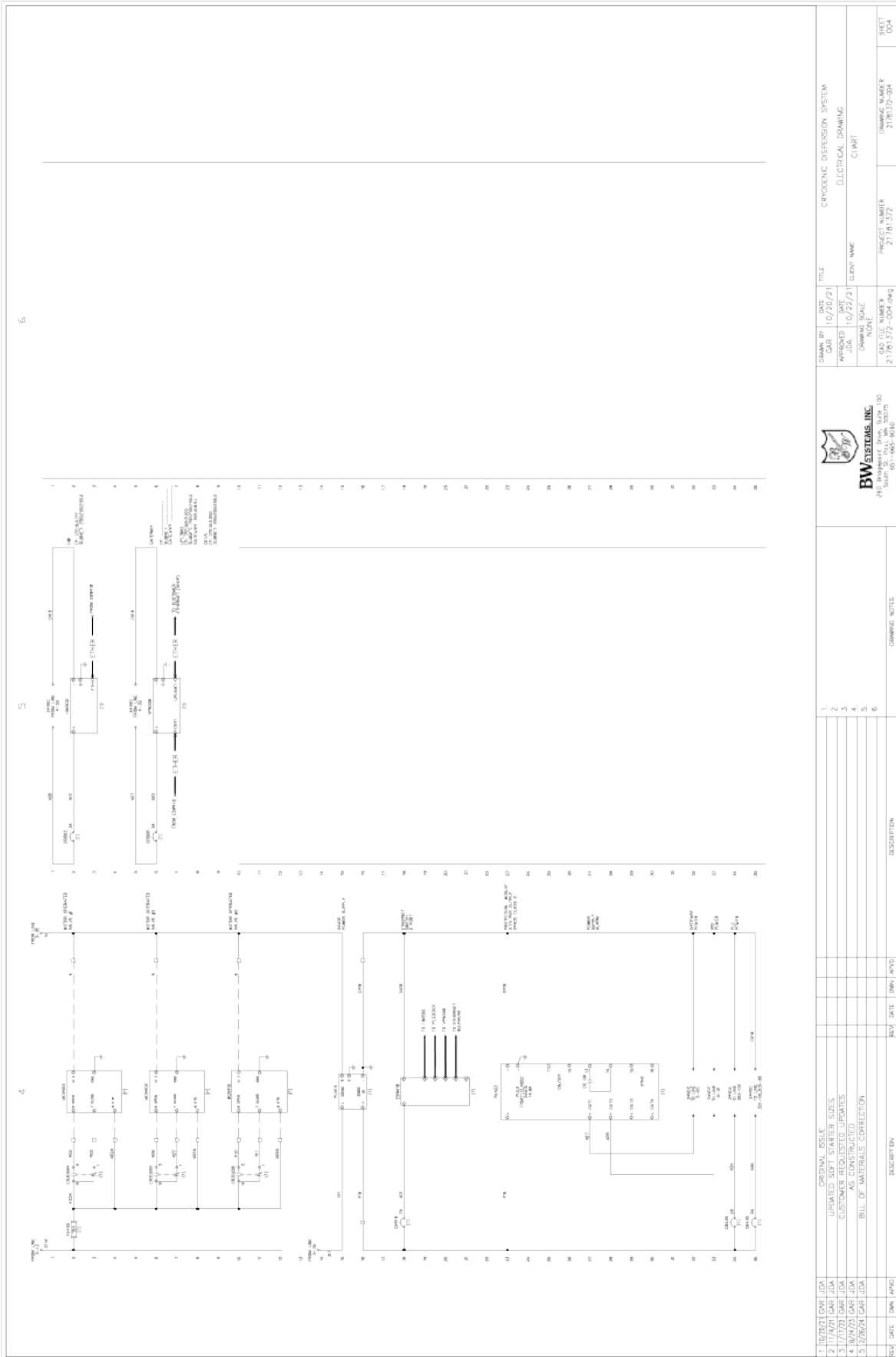

6

5

4

DRWG. NO.	DATE	TITLE
21781372-004-004	10/20/21	CROGENIC DISPERSION SYSTEM ELECTRICAL DRAWING
APPROVED	DATE	CLIENT NAME
JDA	10/22/21	C I ART
DRWG. NO.	SCALE	
21781372-004-004		
PROJECT NUMBER	PROJECT NUMBER	DRAWING NUMBER
21781372-004-004	21781372	21781372-004
		SHEET
		004



NO.	DESCRIPTION
1	
2	
3	
4	
5	
6	

NO.	DESCRIPTION	DATE	BY	APP'D
1	ORIGINAL ISSUE			
2	UPDATED SOFT STARTER SIZES			
3	CUSTOMER REQUESTED UPDATES			
4	AS CONSTRUCTED			
5	BILL OF MATERIALS CORRECTION			

DRAWING NOTES

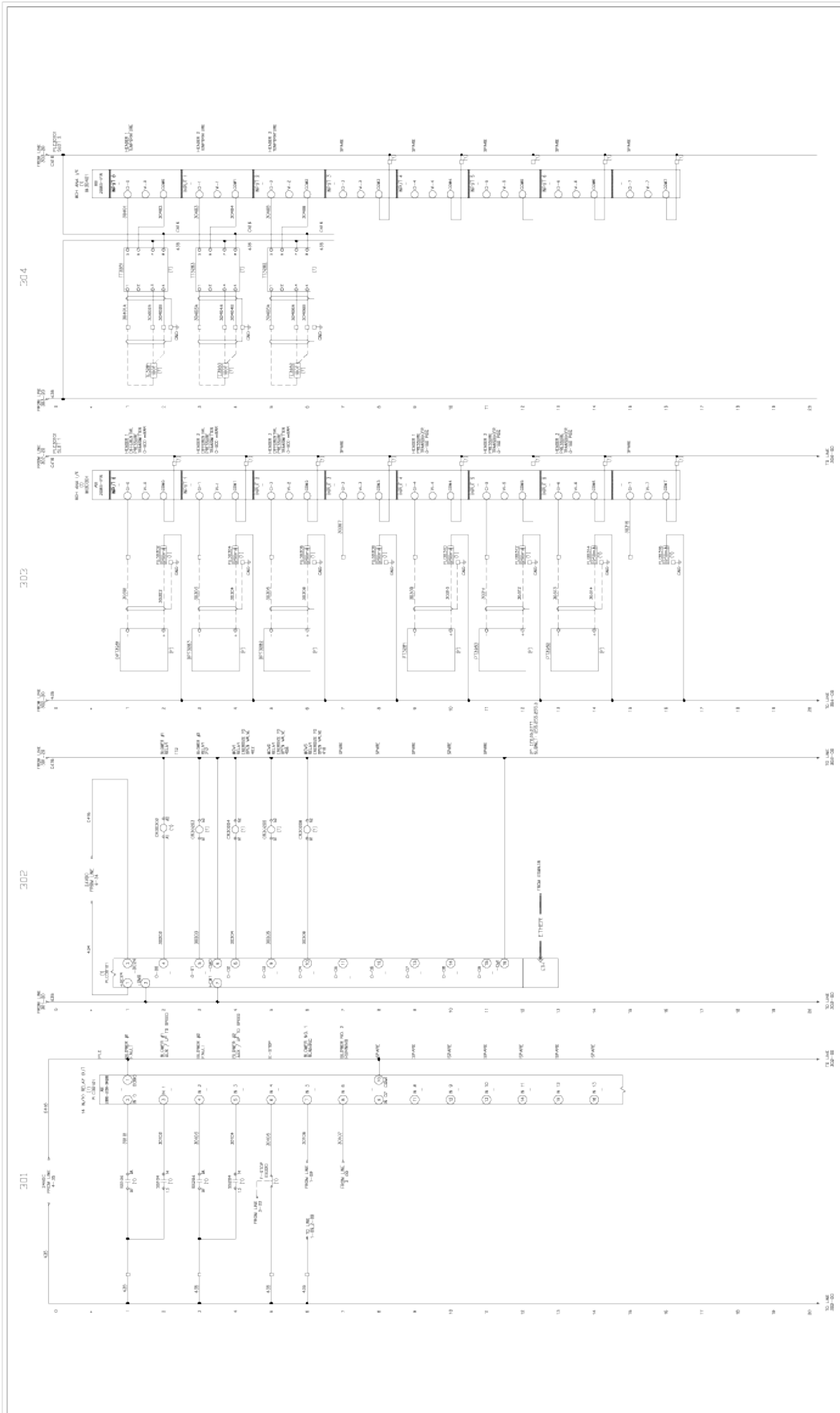

REV	DATE	BY	APPD	DESCRIPTION
1				ORIGINAL ISSUE
2	11/21/21	GAJ		UPDATED SOFT STARTER SIZES
3	11/22/21	GAJ		CUSTOMER REQUESTED UPDATES
4	10/23/21	GAJ		AS CONSTRUCTED
5	12/28/20	GAJ		BILL OF MATERIALS CORRECTION
6				

NO.	DATE	BY	APPD	DESCRIPTION
1				
2				
3				
4				
5				
6				

<p>BW SYSTEMS INC. 210 WASHINGTON AVE. SUITE 100 SOUTH BEND, IN 46601-8003</p>	<p>DATE: 10/28/21 APPROVED: [Signature] JOB: 21781372-301-ONG DRAWN: GAJ SCALE: NONE</p>	<p>TITLE: CIRCULIC DISPERSION SYSTEM PLC I/O WIRING CIRCUIT</p>	<p>PROJECT NUMBER: 21781372 DRAWING NUMBER: 21781372-301</p>	<p>SHEET: 301</p>
---	--	---	--	-------------------

ITEM	SIZE	NAMEPLATE SCHEDULE	NAMEPLATE ITEM
1	1" X 4"		DROGENIC DISPERSION SYSTEM PANEL
2	1" X 4"		SEE DETAIL A
3	0.75" X 3"		PLUGGITY #1 COMPRESSOR OFF ON
4	0.75" X 3"		BLOWER #2 OVERRIDE OFF ON

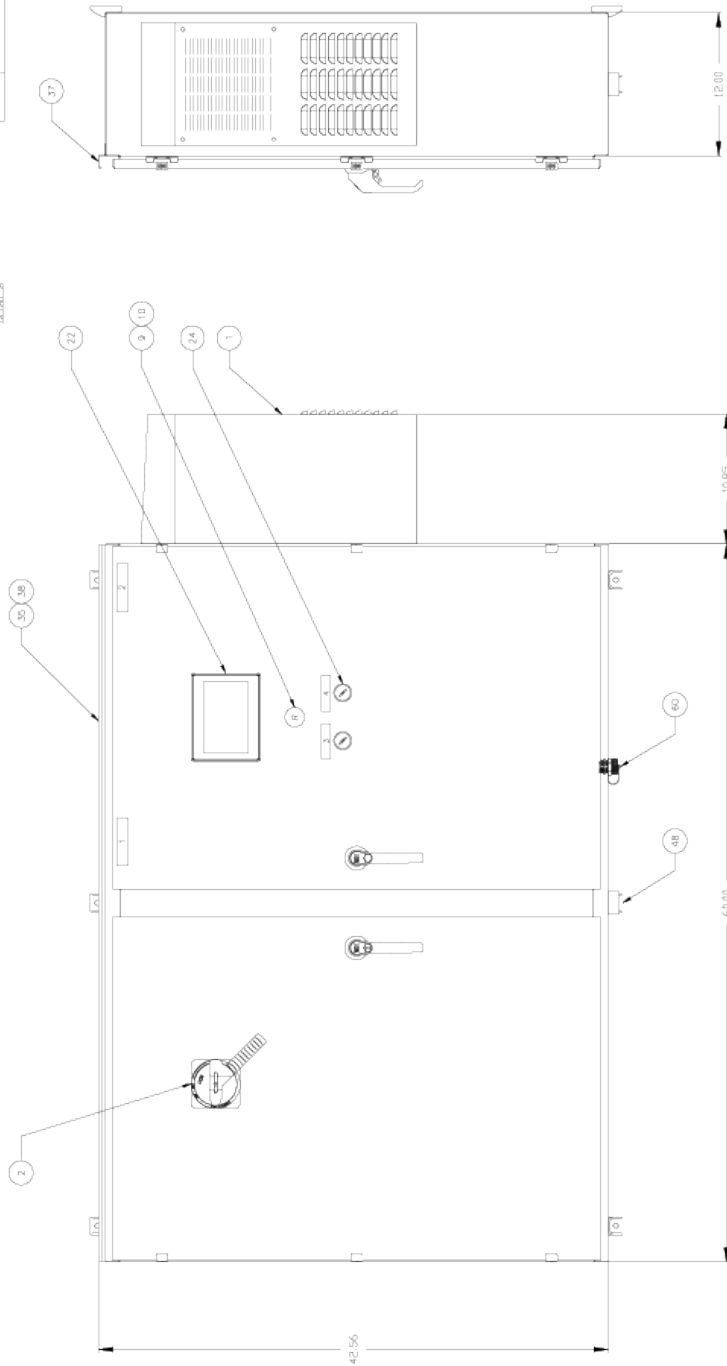
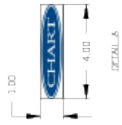

REV	DATE	BY	CHK	APPV	DESCRIPTION
1					ORIGINAL ISSUE
2	11/17/21	JDA			UPDATED SOFT STARTER SIZES
3	1/7/22	JDA			CUSTOMER REQUESTED UPDATES
4	8/24/21	JDA			AS CONSTRUCTED
5	2/28/24	JDA			BILL OF MATERIALS CORRECTION
6					

DRWN BY	DATE	TITLE
JDA	10/20/21	DROGENIC DISPERSION SYSTEM ENCLOSURE LAYOUT

APPROVED	DATE	CLIENT NAME
JDA	10/22/21	CHART

CAD FILE NUMBER	PROJECT NUMBER	DRAWING NUMBER	SHEET
21781.372-400.dwg	21781.372	21781.372-400	400

DRAWING NOTES	
1	
2	
3	
4	
5	
6	



Appendix D – Recommended Spare Parts

Dual Blower Fan Air Disposal Vaporizer – Operation & Maintenance Manual			Appendix D – Recommended Spare Parts D3			
Chart Part #	Description	Qty.	Vendor	Category/Type	Vendor Part #	
11932461	Class 150 FF Gylon Oxygen Cleaned and Bagged	2*	Garlock	Gasket	3502	
21600004	Type T Ring Style, 30 ft. lg. w/ SS Overbraid Stranded Wire	2	Pyromation	Thermocouple	TRB1U-F3B360-2	
21533462	Soft Goods Valve Repair Kit C47W	1	Habonim	Valve	15-RK-C47W-A-A-A-C-AX	
20870323	Resistance Temperature Detector	1	Burns	RTD	200A10B14S035	
22226451	Gauge Pressure Transmitter	1	Yokogawa	Pressure Transmitter	EJX530A-JBS4N-017NN/V1U1/D3/K6	
22226450	Differential Pressure Transmitter	1	Yokogawa	Pressure Transmitter	EJX110A-JHS5G-717NN/V1U1/D3/K6	
21871585	Nozzle Assembly	6	N/A	Nozzle	N/A	
22327364	Fuse Block, 2-Pole	1	Mersen	Fuse Block	USCC2	
22327365	Fuse, 10a, Class cc	3	Bussmann	Fuse	LP-CC-10	
22327366	Fuse, 1-1/4a, Class cc	2	Bussmann	Fuse	LP-CC-1-1/4	
22327367	Fuse, 10a, Class cc	2	Bussmann	Fuse	FRN-R-10	
22327368	Fuse, 2a, Class cc	1	Bussmann	Fuse	LP-CC-2	
22327369	Fuse block, 1-Pole	1	Mersen	Fuse	USCC1	
22327370	Fuse, 8a, Class cc	1	Bussmann	Fuse	LP-CC-8	
22327371	Fuse, 250ma, 5 x 20mm	10	Bussmann	Fuse	GMA-250-R	
22327372	Soft Starter, 108a, 120vac Control	1	Allen-Bradley	Soft Starter	150-C108-NBD	
22327373	Power Supply, 24vdc, 5a	1	Puls	Power Supply	CS5-241	
	* quantity per header					

Appendix E – PLC IP Configuration

PLC IP Configuration

IP Address 172.16.0.5
Subnet Mask 255.255.0.0

SECOMEA IP

IP Address 192.168.1.1
Subnet Mask 255.255.255.0
Gateway IP

Project Air Fan Vaporizer
Date: 8/31/2020

Group	TAG DESCRIPTION	MODBUS ADDRESS	MODBUS ADDRESS(ES) USED	DATA TYPE	COMMENT
CUSTOMER DIGITAL	ENABLE SIGNAL	00001	00001	BOOL	ENABLE SIGNAL IF IN REMOTE MODE
DIGITAL INPUTS	BLOWER 1 FAULT	10001	10001	BOOL	
DIGITAL INPUTS	BLOWER 1 FULL SPEED	10002	10002	BOOL	
DIGITAL INPUTS	BLOWER 2 FAULT	10003	10003	BOOL	
DIGITAL INPUTS	BLOWER 2 FULL SPEED	10004	10004	BOOL	
DIGITAL INPUTS	ESTOP PRESS	10005	10005	BOOL	
DIGITAL INPUTS	SPARE INPUT	10006	10006	BOOL	
DIGITAL INPUTS	SPARE INPUT	10007	10007	BOOL	
DIGITAL INPUTS	SPARE INPUT	10008	10008	BOOL	
DIGITAL INPUTS	SPARE INPUT	10009	10009	BOOL	
DIGITAL INPUTS	SPARE INPUT	10010	10010	BOOL	
DIGITAL OUTPUTS	BLOWER 1 ON	10011	10011	BOOL	
DIGITAL OUTPUTS	BLOWER 2 ON	10012	10012	BOOL	
DIGITAL OUTPUTS	HEADER 1 BYPASS VALVE OPEN	10013	10013	BOOL	
DIGITAL OUTPUTS	HEADER 2 BYPASS VALVE OPEN	10014	10014	BOOL	
DIGITAL OUTPUTS	HEADER 3 BYPASS VALVE OPEN	10015	10015	BOOL	
DIGITAL OUTPUTS	SPARE OUTPUT	10016	10016	BOOL	
DIGITAL OUTPUTS	SPARE OUTPUT	10017	10017	BOOL	
DIGITAL OUTPUTS	SPARE OUTPUT	10018	10018	BOOL	
DIGITAL OUTPUTS	SPARE OUTPUT	10019	10019	BOOL	
DIGITAL OUTPUTS	SPARE OUTPUT	10020	10020	BOOL	
GENERAL DIGITAL	SYSTEM ENABLED	10021	10021	BOOL	
GENERAL DIGITAL	SPARE GENERAL DIGITAL	10022	10022	BOOL	
GENERAL DIGITAL	SPARE GENERAL DIGITAL	10023	10023	BOOL	
GENERAL DIGITAL	SPARE GENERAL DIGITAL	10024	10024	BOOL	
GENERAL DIGITAL	SPARE GENERAL DIGITAL	10025	10025	BOOL	
GENERAL DIGITAL	SPARE GENERAL DIGITAL	10026	10026	BOOL	
GENERAL DIGITAL	SPARE GENERAL DIGITAL	10027	10027	BOOL	
GENERAL DIGITAL	SPARE GENERAL DIGITAL	10028	10028	BOOL	
GENERAL DIGITAL	SPARE GENERAL DIGITAL	10029	10029	BOOL	
GENERAL DIGITAL	SPARE GENERAL DIGITAL	10030	10030	BOOL	
WARNINGS		10031	10031	BOOL	
WARNINGS		10032	10032	BOOL	
WARNINGS		10033	10033	BOOL	
WARNINGS		10034	10034	BOOL	
WARNINGS		10035	10035	BOOL	
WARNINGS		10036	10036	BOOL	
WARNINGS		10037	10037	BOOL	
WARNINGS		10038	10038	BOOL	
WARNINGS		10039	10039	BOOL	
WARNINGS		10040	10040	BOOL	
ALARMS		10041	10041	BOOL	
ALARMS		10042	10042	BOOL	
ALARMS		10043	10043	BOOL	
ALARMS		10044	10044	BOOL	
ALARMS		10045	10045	BOOL	
ALARMS		10046	10046	BOOL	
ALARMS		10047	10047	BOOL	
ALARMS		10048	10048	BOOL	
ALARMS		10049	10049	BOOL	
ALARMS		10050	10050	BOOL	
ANALOG INPUTS	TE3281	30001	30001 - 30002	REAL	
ANALOG INPUTS	TE3283	30003	30003 - 30004	REAL	
ANALOG INPUTS	TE3282	30005	30005 - 30006	REAL	
ANALOG INPUTS	PT3281	30007	30007 - 30008	REAL	
ANALOG INPUTS	PT3282	30009	30009 - 30010	REAL	
ANALOG INPUTS	PT3283	30011	30011 - 30012	REAL	

PLC IP Configuration

IP Address 172.16.0.5
Subnet Mask 255.255.0.0

SECOMEA IP

IP Address 192.168.9.165
Subnet Mask 255.255.255.0
Gateway IP 192.168.9.1

Project Air Fan Vaporizer

Date: 3/25/2021

Group	TAG DESCRIPTION	MODBUS ADDRESS	MODBUS ADDRESS(ES) USED	DATA TYPE	COMMENT
ANALOG INPUTS	DPT3281	30001	30001 - 30002	REAL	
ANALOG INPUTS	DPT3283	30003	30003 - 30004	REAL	
ANALOG INPUTS	DPT3282	30005	30005 - 30006	REAL	
ANALOG INPUTS	PT3281	30007	30007 - 30008	REAL	
ANALOG INPUTS	PT3282	30009	30009 - 30010	REAL	
ANALOG INPUTS	PT3283	30011	30011 - 30012	REAL	
ANALOG INPUTS	SPARE ANALOG IN	30013	30013 - 30014	REAL	
ANALOG INPUTS	SPARE ANALOG IN	30015	30015 - 30016	REAL	
RTD INPUT	TE3281	30017	30017 - 30018	INTx10	
RTD INPUT	TE3282	30019	30019 - 30020	INTx10	
RTD INPUT	TE3283	30021	30021 - 30022	INTx10	
RTD INPUT	SPARE RTD	30023	30023 - 30024	INTx10	
RTD INPUT	SPARE RTD	30025	30025 - 30026	INTx10	
RTD INPUT	SPARE RTD	30027	30027 - 30028	INTx10	
THERMOCOUPLES	TE301	30029	30029 - 30030	INTx10	
THERMOCOUPLES	TE302	30031	30031 - 30032	INTx10	
THERMOCOUPLES	TE303	30033	30033 - 30034	INTx10	
THERMOCOUPLES	TE101	30035	30035 - 30036	INTx10	
THERMOCOUPLES	TE102	30037	30037 - 30038	INTx10	
THERMOCOUPLES	TE202	30039	30039 - 30040	INTx10	
THERMOCOUPLES	TE401	30041	30041 - 30042	INTx10	
THERMOCOUPLES	SPARE TC	30043	30043 - 30044	INTx10	
GENERAL ANALOG	FORCE FAN HEARTBEAT	30045	30045	WORD	0-999 CHANING ONCE/SECOND
GENERAL ANALOG	SPARE	30046	30046	WORD	
GENERAL ANALOG		30047	30047 - 30048	REAL	
GENERAL ANALOG		30049	30049 - 30050	REAL	
GENERAL ANALOG		30051	30051 - 30052	REAL	
GENERAL ANALOG		30053	30053 - 30054	REAL	
GENERAL ANALOG		30055	30055 - 30056	REAL	
GENERAL ANALOG		30057	30057 - 30058	REAL	
GENERAL ANALOG		30059	30059 - 30060	REAL	
GENERAL ANALOG		30061	30061 - 30062	REAL	
GENERAL ANALOG		30063	30063 - 30064	REAL	
GENERAL ANALOG		30065	30065 - 30066	REAL	
GENERAL ANALOG		30067	30067 - 30068	REAL	
GENERAL ANALOG		30069	30069 - 30070	REAL	
GENERAL ANALOG		30071	30071 - 30072	REAL	
GENERAL ANALOG		30073	30073 - 30074	REAL	
GENERAL ANALOG		30075	30075 - 30076	REAL	
GENERAL ANALOG		30077	30077 - 30078	REAL	
GENERAL ANALOG		30079	30079 - 30080	REAL	
GENERAL ANALOG		30081	30081 - 30082	REAL	
GENERAL ANALOG		30083	30083 - 30084	REAL	
GENERAL ANALOG		30085	30085 - 30086	REAL	
SETPOINTS		30087	30087 - 30088	REAL	
SETPOINTS		30089	30089 - 30090	REAL	
SETPOINTS		30091	30091 - 30092	REAL	
SETPOINTS		30093	30093 - 30094	REAL	
SETPOINTS		30095	30095 - 30096	REAL	
SETPOINTS		30097	30097 - 30098	REAL	
SETPOINTS		30099	30099 - 30100	REAL	
SETPOINTS		30101	30101 - 30102	REAL	
SETPOINTS		30103	30103 - 30104	REAL	
SETPOINTS		30105	30105 - 30106	REAL	
SETPOINTS		30107	30107 - 30108	REAL	
SETPOINTS		30109	30109 - 30110	REAL	