

# DUAL SDOX<sup>®</sup> 600

BY BLUEINGREEN

**SUPERSATURATED DISSOLVED OXYGEN**



- 1 A BIG Solution With A Small Footprint.** Treat more flow with greater treatment demands in a smaller footprint using a fraction of the energy costs. Each Dual SDOX<sup>®</sup> container can treat up to 4 MGD (15,142 m<sup>3</sup>/day) of typical domestic wastewater.<sup>1</sup>
- 2 The Modular, Scalable, Building-Block Of Your Solution.** Each fully-functional water treatment system – packaged in a robust, 20-ft ISO shipping container – contains two, skid-mounted SDOX<sup>®</sup> 600 units and the balance of equipment. Each Dual SDOX<sup>®</sup> 600 can deliver more than 10,000 lbs. (4,500 kg) of oxygen per day, with the number of containers required being a function of your treatment needs.
- 3 Self-Contained. Easily Deployed.** The insulated, containerized award-winning solution includes all electrical distribution, transformers, lighting, ventilation and climate controls, further reducing infrastructure costs and increasing the design's utility in temporary applications, such as emergency environmental remediation or capacity constraints.
- 4 Intelligent. Efficient.** Intelligent controls automatically maintain operator-selected dissolved oxygen levels or delivery set-points using probes within the treatment process. Variable frequency drives enable pumps to supply only the water required for treatment, saving energy while achieving oxygenation objectives.



AWARD WINNER



## DESIGN

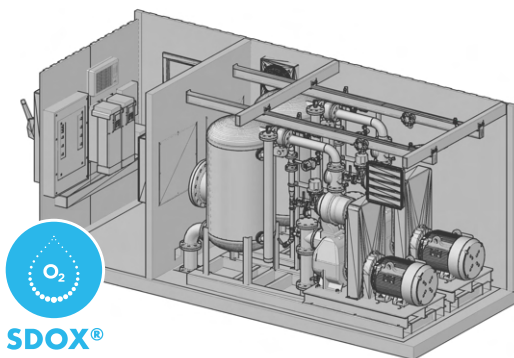

SDOX<sup>®</sup>

## COST COMPARISON

**Comparison of Annual Operating Costs  
10-year Net-Present Value per MGD \*\***

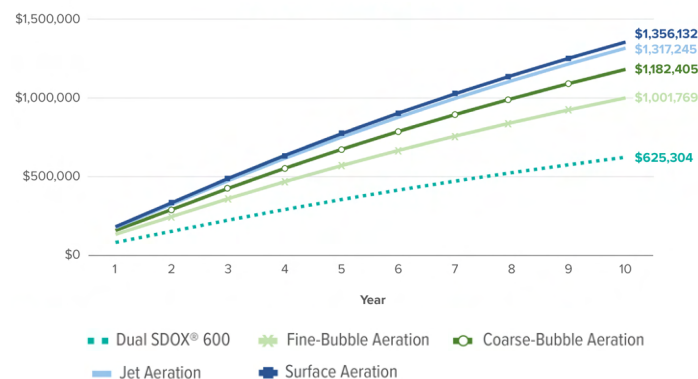

## LOWEST O+M COSTS



**Lowest Operating + Maintenance Costs**  
SDOX<sup>®</sup> technology has the lowest operating and maintenance costs. O+M costs of fine-bubble aeration are 160% higher and those of jet and surface aeration are more than 210% higher.\*\*



**Smart Use of Capital**  
Operating at full capacity, replacing mechanical and diffused aeration equipment with a Dual SDOX<sup>®</sup> 600 solution will payback capital costs within 2-to-3 years – higher energy costs and concentrations of mixed liquor and suspended solids (MLSS) accelerate payback. Using SDOX<sup>®</sup> to replace chemical treatments of hydrogen peroxide typically payback within 1-to-2 years – higher flows and treatment demands accelerate payback.

### Notes

\* MGD = million U.S. gallons per day (~3,785 cubic meters per day).  
 \*\* Based on typical domestic wastewater, assuming the cost of electricity is US\$0.10/kwh and cost of oxygen is US\$0.05/lb.  
<sup>1</sup> Typical domestic wastewater conditions: CBODs: 220, TSS: 220, TKN: 40, Refract ORG N: 1, TP: 8 (mg/liter).



AMERICAS  
+1.304.Talk.BIG

ASIA PACIFIC  
+60 12 354 0710

EMEA  
+420 606 623 361

INDIA  
+91 9717032880  
+1.330.805.2615

**Design Flexibility in a Plug + Play Solution:** The most efficient technology packaged in a dependable, robust, shipping container offers design flexibility. Rapidly and easily deployed and scaled to your needs or easily removed or transitioned to new locations as your needs change.

**Ease of Installation:** Single point connections for inlet and outlet water or mixed liquor for each SDOX® as well as incoming electrical and oxygen supply make design and installation fast and efficient.

**Communications Ready:** Cellular modems allow real-time monitoring from internet browsers and smart phones. Industry leading PLCs make SCADA connectivity simple. Instant-messaging enables operator alerts of any variation outside of normal operating conditions.

**Operational Continuity:** Side-stream dissolution enables retrofitting to any in-pipe, basin or lagoon-based process without the need to drain the treatment basin, disturb existing equipment or otherwise interrupt operations.

**Reduced Downtime + Maintenance Costs:** Fewer moving parts that are less likely to fail significantly reduces potential sources of failure and maintenance requirements. Most periodic maintenance may be undertaken without the need for heavy equipment.

**Quality Guaranteed:** Attention to design details, industry leading components and superior materials and workmanship ensure quality. Factory-tested for functionality and performance to minimize construction and start-up time.

**Single-Source Responsibility:** Fully integrated and skid mounted dissolution and injection system - including pump/motor, VFD, control panel with PLC and HMI, optional DO feedback control loop, and associated piping and valves - all provided by BlueInGreen.

**Stellar Support:** From design through long-term operation, our experienced engineers and technicians are committed to success and providing the insight and resources needed along the way.

**Built-In Safeguards + Redundancy:** The Dual design operates two SDOX® systems in parallel, offering a minimum of 50% operating capacity in the unlikely event of a pump failure. The parallel Dual SDOX® system simplifies the design of mission critical installations requiring emergency, redundant capacity on immediate reserve.

**Enhanced Worker Safety:** Unlike conventional aeration systems, most periodic maintenance may be undertaken outside of the treatment basin on dry land, reducing the frequency and duration of time that people must work with electricity within the treatment basin or lagoon.

**The Sustainable Solution:** Reduce energy use and greenhouse gas emissions by up to 75% compared to mechanical and diffused aeration technologies.

**Full-Service Contracts:** Proven technology supported by the engineering and operational expertise you need – all with the flexibility of a monthly contract.

**Biological Treatment + Nutrient Removal**

Using SDOX® systems and O<sub>2</sub> for more effective and efficient biological treatment of wastewater and enhanced nutrient removal.

**Benefits:**

- Up to a 75% reduction in energy use and GHG emissions.
- Treats more waste in a smaller footprint, enhancing the treatment capacity of overloaded, under-sized or constrained systems, often eliminating the need for expensive increases in the physical volume of treatment basins.
- Superior performance in high concentrations of mixed liquor and suspended solids (MLSS), enabling longer solid retention times (SRT) required for consistent nitrification and better treatment. Maintains oxygen transfer efficiency above 90% in wastewater with MLSS concentrations of 10,000 mg/L.

**Tyson Foods** Replaced mechanical aeration equipment at a regional rendering facility. Wastewater engineers forecast an estimated energy savings and greenhouse gas reduction of up to 79%, while adding significant redundant treatment capacity. The figure to the right illustrates the trend in energy use as Tyson wastewater treatment operators became more familiar with the equipment and progressively shut down the pre-existing, mechanical aeration equipment.

**Simmons Foods** “In general, we’re treating more flow with higher loads and better removal rates while seeing lower operating costs. Overall, our BOD and total nitrogen removal have both increased by about 10%.” Andy Brashear, Env. Mgr. “We are extremely pleased with the results of the two SDOX® systems. Aside from making it easier for us to stay in compliance, once fully optimized, the energy savings alone are expected to justify the equipment.” Seth Walters, Sr. Director, Env. Quality.

Tyson Power Usage with SDOX®



**Environmental Remediation of Rivers, Lakes + Reservoirs**

Using SDOX® systems and O<sub>2</sub> for mobile, rapid-response, emergency sanitation and environmental remediation.

**Benefits:**

- No-bubble, molecular dissolution evenly distributes O<sub>2</sub> in a form that is more available to micro-organisms, increasing biological activity and the ability to manage BOD.
- Target specific thermal layers in the water column, using less oxygen to maintain aerobic conditions below the thermocline without causing turnover – mitigates sediment oxygen demand, disrupts the nutrient loading-and-release cycle, the release of phosphorus and associated algae blooms.

**U.S. Army Corps of Engineers** “Despite increasing temperature, the SDOX® provided an ideal habitat for Lake Tenkiller’s trout population, preventing fish kills in Oklahoma’s hot summer months.”

**Oklahoma Water Resources Board** Using SDOX® and O<sub>2</sub> to induce desirable physical and chemical conditions in the 5,439 acre (2,201 ha) lake. “Oxygenation of the lake’s hypolimnion layer provides aerobic lake habitat, improves quality of raw drinking water for municipalities and reduces recreational health risks due to the growth of harmful algae.”

**Odor Control + Chemical Replacement**

Using SDOX® system and O<sub>2</sub> to control odor by oxidizing and suppressing the formation of sulfides, replacing chemical applications of hydrogen peroxide and catalysts.

**Benefits:**

- Improved Odor Control
- Lower Operating Costs

**Georgia Pacific** In addition to managing odor by enhancing ORP, DO and the ability of the system’s biology to remove soluble BOD, transitioning from hydrogen peroxide treatments to oxygenation resulted in an estimated 62% reduction in chemical costs, saving millions in annual operating costs.

**U.S. Pork Producer** The SDOX® solution provides the facility with effective treatment while eliminating approximately US\$3 million in annual chemical costs.

**Aerobic Digestion**

Using SDOX® systems and O<sub>2</sub> to produce biologically stable residuals that may be recycled into the environment as an organic fertilizer or soil amendment.

**Benefits:**

- Reduces digestion time and energy use by up to 75% compared to conventional, aerobic digesters.
- Uses less space to effectively treat 100% thicker solids.
- Produces biologically stable bio-solids with virtually no odor or vector attraction, fulfilling 40 CFR Part 503 requirements.

**Telluride, CO** Replaced coarse-bubble diffusers with an SDOX® system, increasing the treatment capacity of the previously overloaded facility, eliminating odor and the need to construct additional treatment basins.

