

Spencer®

Specials Are Our Standard

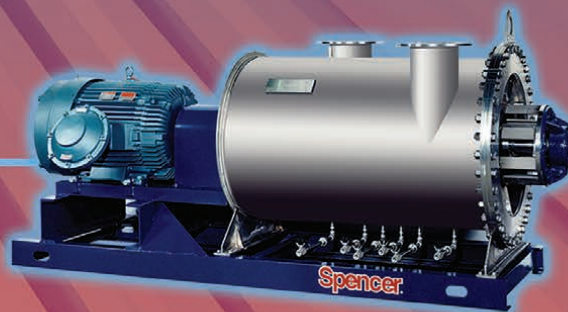

Custom Blowers and Gas Boosters
For Air and Gas Handling Applications

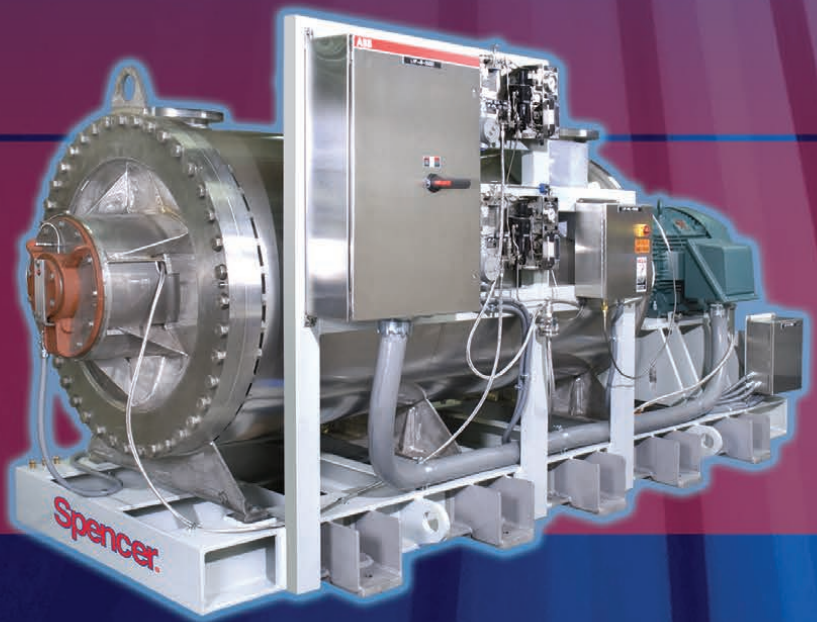
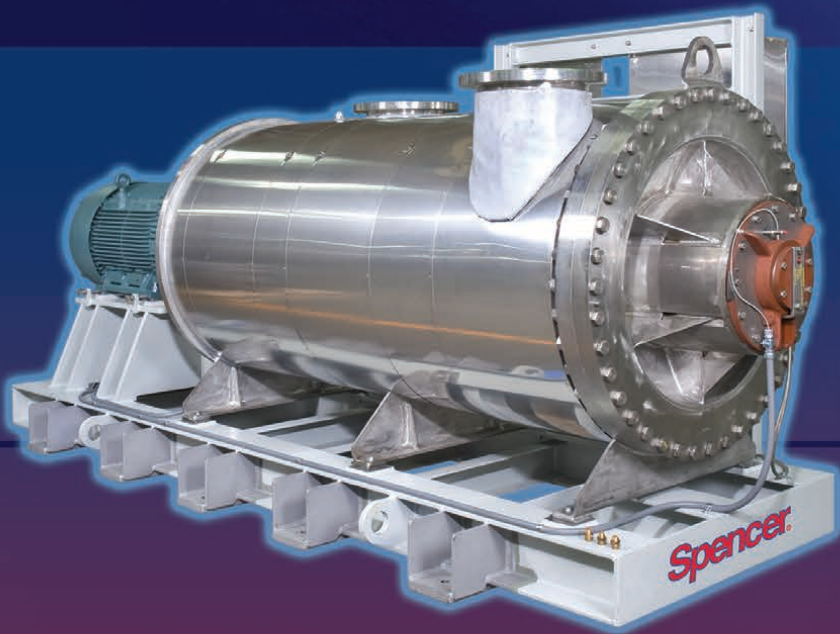

With our unique Engineering Edge, Spencer stands apart to make your equipment special and make your process work

For what we provide, Spencer is the sole source for the whole world

Spencer solves air and gas handling challenges that are so difficult, sometimes the only alternative to our solution is to change the process.

Every design is unique and highly specialized for its target application. At the same time, all Spencer blowers have one thing in common: they are extremely efficient at what they do.

We have built a global presence on our reputation as the company to contact for the most difficult applications, including environments with corrosive, toxic and other gases such as sulfides, nitrogen, halogens, acids, cyanides and ammonia. Our experts engineer, design and manufacture blower or gas booster solutions that meet:

- Temperatures to 1100 °F (593 °C)
- Casing design pressures to 1000 psig (6895 kPa)
- Inlet pressures to 900 psig (6205 kPa)
- Differential pressures to 60 psig (414 kPa)
- Volume flows to 30000 icfm (50977 m³/hr)
- Highly restrictive shaft sealing or gastight requirements

The industry's leading technical resource for special blowers and gas boosters

Since Ira Spencer's first air handling systems in 1892, generations of Spencer specialists have been accumulating unique capabilities that can be focused on your needs. Today, our staff of professional engineers and other air and gas moving experts continues to lead the industry in innovation.

Working in an extensive development laboratory, Spencer specialists perform tests on custom-engineered products, evaluate results and continuously improve blower and gas booster solutions. From material compatibility tests to gas sealing studies, the development facility is equipped for every aspect of in-depth technical support.

Our global network of company-trained manufacturers' and independent representatives includes a Beijing-based Spencer office and service center. This network comprises the industry's most extensive representative organization, ready to provide local liaison for you during system planning, construction, installation, startup and operation nearly anywhere in the world.

More choices, more options, and more experience than any other source

During more than a century of pioneering in this field, Spencer has set the pace for innovation, introducing the first hermetically sealed gas boosters, the first with UL Listed natural gas booster products, and the first to be approved for use in nuclear breeder reactors.

Our comprehensive blower and gas booster product line includes fabricated single- and multistage centrifugal blowers, Power Mizer® cast centrifugal blowers, gas boosters, Vortex® regenerative blowers, and other related system accessories, such as electrical control panels.

To ensure this full range of air and gas handling equipment performs flawlessly to meet very tough requirements – including hot, high-pressure, toxic or corrosive gases – our custom blowers and gas boosters are fabricated from special metals with specific strength or resistant properties. We utilize corrosion-resistant coatings, restrictive shaft sealing and leak-tight hermetic designs with leakage rates down to 10⁻⁹cc/sec.

Only Spencer offers the process industry more choices, more options and more experience in providing air and gas handling equipment. Specials are our standard, so no matter what your requirement is, Spencer is the source for your solution.



Blower and Gas Booster Designs



Standard Overhung Multistage Centrifugal

Our most popular design, with impellers mounted on an extended motor shaft. Simple two-bearing design reduces maintenance.

Pressure: to 5.5 psig (38 kPa)

Volume: to 7,000 icfm (198 m³/min)

Power: to 150 hp (112 kW)

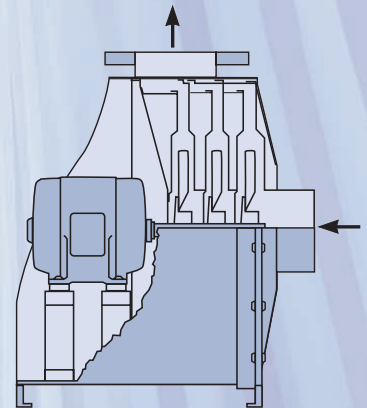

Four Bearing Overhung Multistage Centrifugal

Impellers are mounted on the blower shaft, which is coupled to a standard shaft motor. Rotating elements are supported by a rigid bearing bracket. Also available in belt drive arrangement.

Pressure: to 8 psig (55 kPa)

Volume: to 9,000 icfm (255 m³/min)

Power: to 300 hp (224 kW)

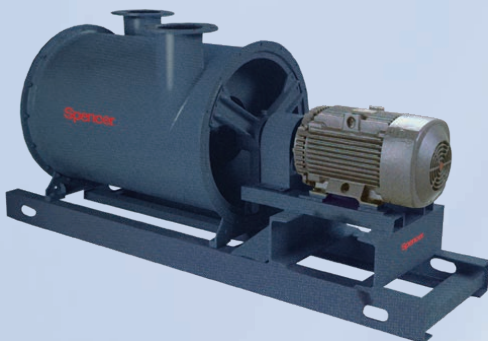
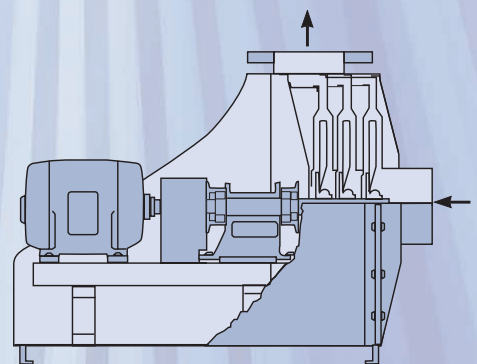

Four Bearing Outboard Multistage Centrifugal

For higher pressure applications. Impellers are mounted between supporting bearings. Outboard bearings are a matched set, one for radial loads, the other for thrust loads. Inboard bearing absorbs a share of the radial load. The blower is coupled to a standard shaft motor.

Pressure: to 20 psig (138 kPa)

Volume: to 30,000 icfm (840 m³/min)

Power: to 1250 hp (932 kW)

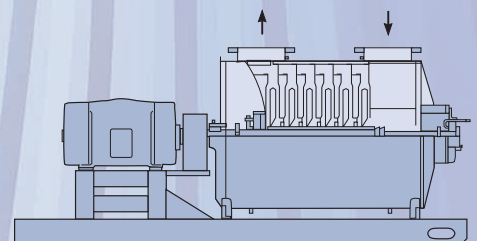

Blower and Gas Booster Designs



Power Mizer® High Efficiency Multistage Centrifugal

Made with rugged cast components for extra-heavy-duty service. Unique three-dimensional bladed impellers and other advancements produce peak adiabatic efficiencies above 80%. The blower is coupled to a standard shaft motor.

Pressure: to 28 psig (193 kPa)

Volume: to 35,000 icfm (991 m³/min)

Power: to 3700 hp (2759 kW)

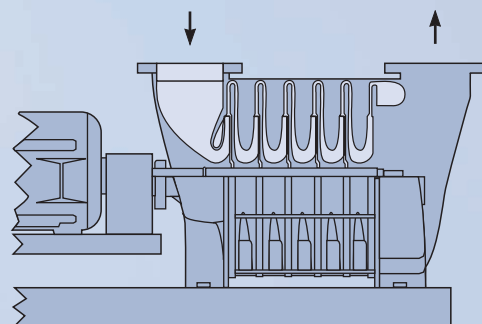

Single-Stage Centrifugal

Scroll design blowers, either medium-duty for low pressure requirements or heavy-duty RB type for higher performance. Impeller is mounted on the blower shaft. Also available in Arrangement 8 (four bearing overhung) and Arrangement 9 (belt drive) configurations.

Pressure: to 3.5 psig (24 kPa)

Volume: to 50,000 icfm (1416 m³/min)

Power: to 800 hp (597 kW)

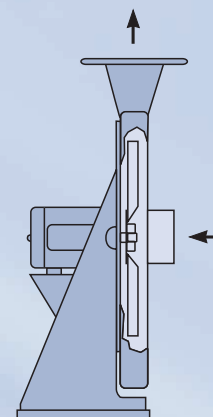

Vortex® Single-Stage Regenerative

Compact design featuring TEFC or explosion-proof motors with quiet operation and stable airflow. Choice of direct drive or belt drive. Special seals and coatings are available.

Pressure: to 3.9 psig (27 kPa)

Volume: to 645 icfm (18 m³/min)

Power: to 15 hp (11 kW)

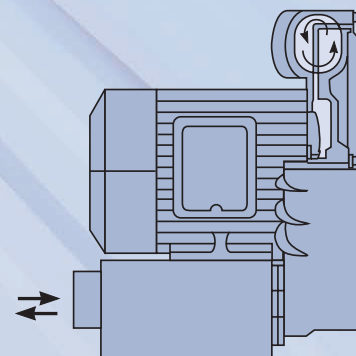

Blower and Gas Booster Designs

Hermetic Gas Boosters



Hermetic construction can be supplied where the gas composition and temperature are compatible with available motors. Electrical connections are made through a terminal box on the outside of the casing. Leakage rate can be as low as 10^{-9} cc/sec.

Spencer also has a standard line of UL Listed natural gas boosters.

Pressure: to 5.5 psig (38 kPa)

Volume: to 7,000 icfm (198 m³/min)

Power: to 150 hp (112 kW)

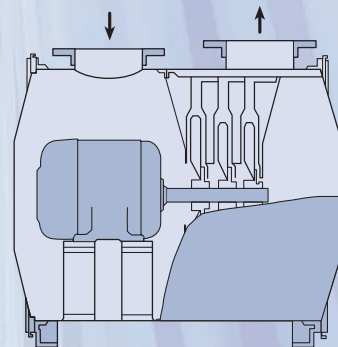

High Pressure Gas Boosters



High pressure blowers are available in all of Spencer's fabricated blower configurations: standard overhung, four bearing overhung, four bearing outboard, single-stage centrifugal and hermetic designs. All pressure vessels are built using ASME Code guidelines and can be code stamped if required. Casing design pressure can be up to 1000 psig (6895 kPa).

Pressure: to 20 psig (138 kPa)

Volume: to 15,000 icfm (425 m³/min)

Power: to 1250 hp (932 kW)

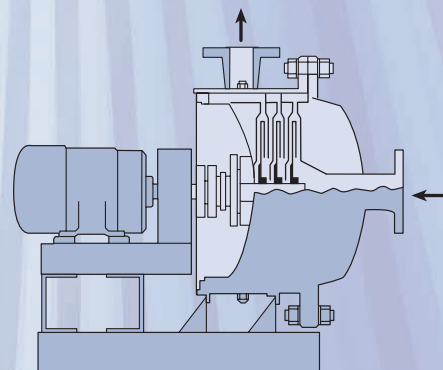

High Temperature Gas Boosters

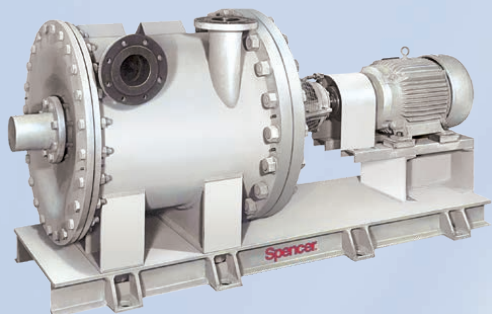

These special blowers, capable of withstanding temperatures up to 1100 °F (593 °C), are available in various configurations. They feature special water-cooled bearings, special seals and packing, and centerline mounted casings to accommodate thermal expansion.

Pressure: to 20 psig (138 kPa)

Volume: to 15,000 icfm (425 m³/min)

Power: to 1250 hp (932 kW)

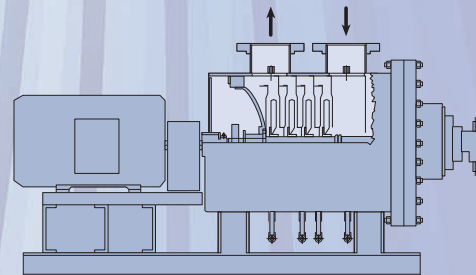

How Spencer Makes it Special

Samples of actual customer solutions

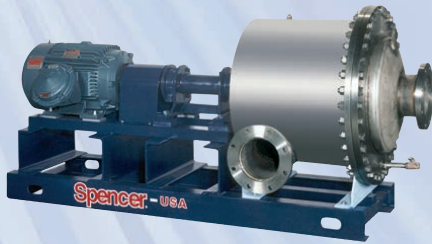

Rich Fume Blower

- 90 psig casing design
- 316LSS construction
- Ryton® coated 316LSS impellers

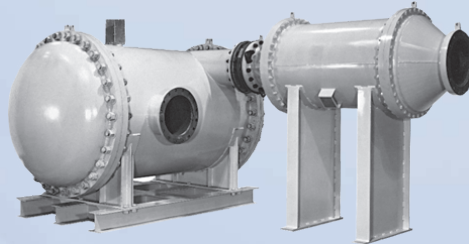

Hermetic Gas Booster

- 400 hp, 1750 RPM
- ASME Stamped Section VIII casing and heat exchanger
- 150 psig casing design

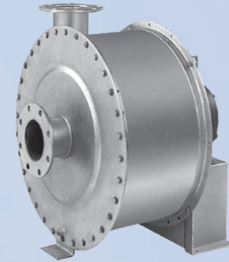

Steam Packing Gland Exhauster

- Carbon steel casing and stationary internals with epoxy coating
- Anodized aluminum impellers
- End head drain

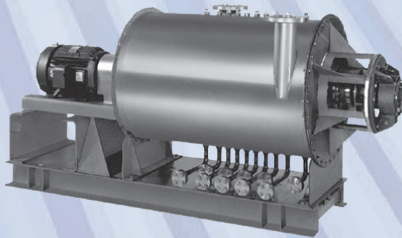

Terephthalic Acid Dryer

- 316LSS casing and wetted internals
- 1.5 mm corrosion allowance
- 304SS covered baseplate
- SS flush and drain connection with individual SS ball valves
- ASME PTC-10 performance test



Lean Fume Blower

- 316LSS construction
- Packing box with nitrogen purge, with accommodation for future mechanical seal



Power Mizer Vapor Recovery Blower

- Heresite coated cast iron construction
- Carbon ring shaft seals
- API 617 base

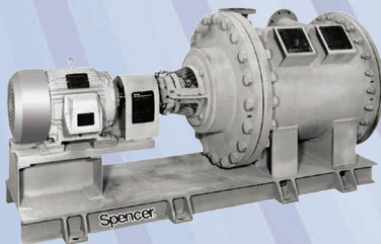

Nuclear Safety System Blower

- NQA-1 compliant design
- 40-year design life
- ASME Stamped Section III, Class 2 casing
- Unique outboard bearings inside pressure vessel

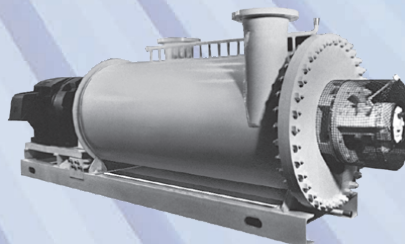

Radioactive Waste Processing Blower

- Four bearing outboard design with 15 stages
- Manifold flush with drain connections
- Water-cooled packing box and radial bearing

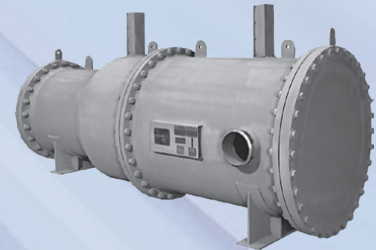

Dual Hermetic Blowers

- Blowers operate in series, sealed in one pressure vessel
- ASME Stamped Section VIII

Shaft Seal Designs

Spencer offers a variety of seals to meet broad application needs. Seal selection is influenced by the leakage rate, maintenance requirement and also by the type of process gas, its pressure and temperature.

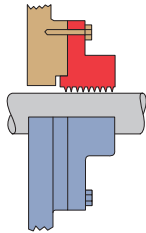

Labyrinth Seal

Advantages: Simplest and least expensive of noncontacting types.

Disadvantage: Highest leakage rate among noncontacting seals.

Type: Dry, noncontacting

Leakage: 3-6 scfm (5-10 m³/hr)

Max. Temp.: 1000 °F (538 °C)

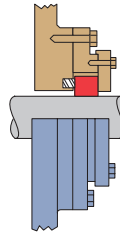

Single Carbon Ring

Advantages: Inexpensive, lower leakage than packing box. Low maintenance.

Disadvantages: Limited life capacity, typically two to three years. Leakage increases with time.

Type: Dry, contacting

Leakage: 0.1-1 scfm (0.2-1.7 m³/hr)

Max. Temp.: 800 °F (427 °C)

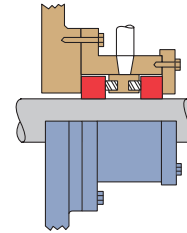

Double Carbon Ring

Advantage: Near-zero process gas leakage when cavity between seals is purged with air or nitrogen under higher pressure.

Disadvantages: Higher cost and maintenance than single ring. Minor contamination of process gas by purge gas.

Type: Dry, contacting

Leakage: 0.1 scfm (0.2 m³/hr)

Max. Temp.: 800 °F (427 °C)

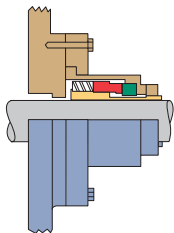

Single Mechanical Seal

Advantages: Near-zero leakage, low maintenance.

Disadvantage: Sensitive to misalignment.

Type: Dry, noncontacting

Leakage: 0.01 scfm (0.02 m³/hr)

Max. Temp.: 800 °F (427 °C)

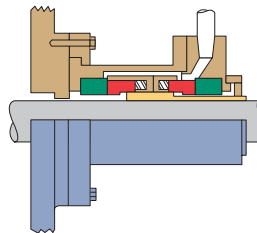

Double Mechanical Seal

Advantages: Highest sealing effectiveness of all seal types, low maintenance.

Disadvantages: Sensitive to misalignment. Minor contamination of process gas by purge gas.

Type: Dry, noncontacting

Leakage: 0 scfm (0.0 m³/hr)

Max. Temp.: 800 °F (427 °C)

► **NOTE:** Process gas leakage depends on many factors including inlet pressure, differential pressure, shaft diameter, operating speed and seal condition. Leakage ratings are furnished for comparison only.

Gas Sealing Fundamentals

Gas leaks occur most often where the power shaft passes through the blower casing. Every shaft seal leaks, but leakage can be restricted to acceptable levels through proper seal selection.

Dry-running seals are recommended by Spencer because they do not contaminate the process gas with cooling or lubricating liquids. They are also generally simpler, less expensive, easier to maintain, more reliable and longer lasting than wet seals.

Dry-running, contacting seals have touching seal faces that wear, generating a lubricant such as graphite powder. These seals are mainly used for low pressure, low temperature

applications. Because they wear continually, these seals generate friction and heat, and must be periodically replaced. The power requirement is higher than for noncontacting seals.

Dry-running, noncontacting seals balance hydrostatic and hydrodynamic forces to keep seal faces from touching during operation. These seals do not wear and hence need no maintenance.

Single and double mechanical seals are preferred by Spencer for handling hazardous, corrosive and poisonous gases. They have very low, unvarying leakage rates.

The double mechanical seals offered by Spencer have a unique dynamic sealing process. As the mating ring turns, a groove pumps purge gas inward, creating a compressed gas cushion that prevents escape of process gas.

Materials and Coatings

Spencer's standard material of construction is carbon steel with aluminum impellers. Standard coatings are epoxy primer for all interior and exterior surfaces, and a urethane exterior topcoat.

Custom metals and coatings

Scores of other metals and coatings are available for customized performance. Spencer engineers have unparalleled experience in selecting and applying unusual metals and coatings, because they deal every day with the most difficult applications in the world.

One common approach is to combine standard and custom materials. Specialized alloys can be used for components exposed to corrosive gases; less expensive materials can be used for all unwetted parts. The result is a blower that has special protection where it's needed and economy where it's not.

Beneficial properties

Custom metals and coatings offer specific properties, such as:

- Corrosion resistance
- Abrasion resistance
- Spark-resistant operation
- Non-stick (anti-fouling) performance
- High or low temperature resistance

Which are better, special metals or coatings?

Coatings are often used for their anti-fouling properties or for passivation of metal surfaces. But in many other instances, coatings and special materials are simply two ways of reaching the same result. Selecting one over the other depends on your preferences and your circumstances. You need to examine economic factors such as the cost of coatings vs. exotic alloys, and life cycle considerations (e.g., are you looking for 40,000 or 4,000,000 duty cycles?).

Sometimes it makes sense to use "disposable" coated blowers and replace them periodically. Or, in a critical process, it might be vital to avoid down time by using long-life alloys.

In some cases, a special coating must be accompanied by a special material (e.g., high temperature coatings and high temperature steels must be used together) to deliver consistent results.

Note that coatings can be applied to counter internal or external conditions. A special exterior paint might be used in humid environments to prevent rust, for example.

A corrosion allowance may provide all the protection you need

If corrosion is the application problem and its rate is slow, predictable and acceptable, you may be able to avoid using either coatings or expensive special metals. A corrosion allowance involves a blower casing metal that is thicker than usual to accommodate corrosion. Thus, a thick section of 304SS might be used instead of a much more costly casing of Hastelloy.

The thickness of the corrosion allowance can be specified to reach a desired service life for the blower.

Materials of Construction

| | |
|-------------------------------|----------------|
| Carbon steel | Cor-Ten® |
| Cast iron | Monel 400 |
| Aluminum | Hastelloy C22 |
| 300 Series stainless steel | Hastelloy C276 |
| 400 Series stainless steel | Inconel 625 |
| Carpenter 20® stainless steel | AL6XN |
| AR steel | Titanium |
| FE 255® | Brass/bronze |

Special Coatings

| | |
|--|---|
| Teflon® | Plastisol® PVC |
| Ryton® | Galvanizing |
| Anodizing | Special paint (e.g., epoxy, enamel, polyurethane) |
| Electroless nickel | |
| Heresite® or Bisonite® baked phenolic | |

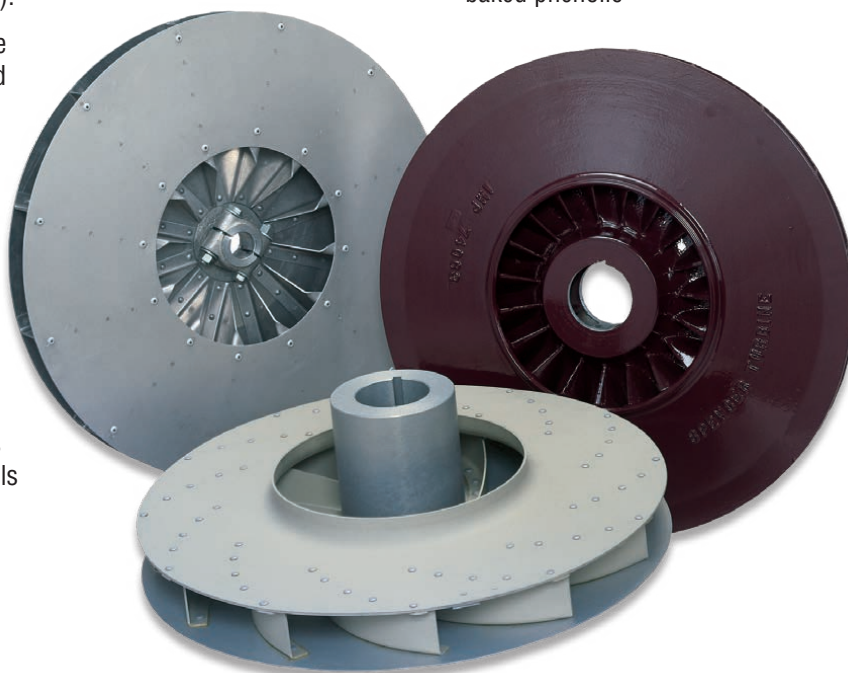

Special Design Features and Accessories

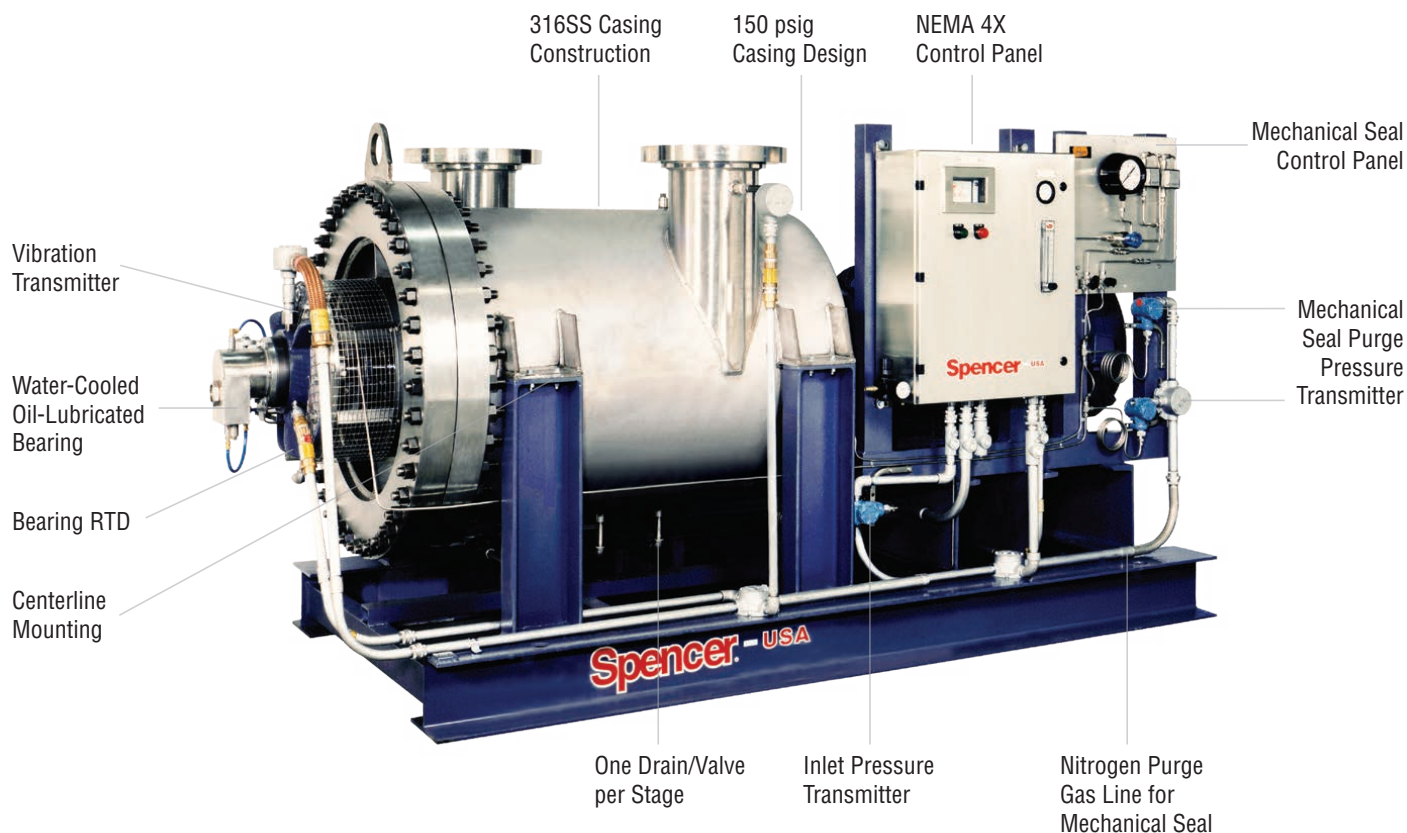

Spencer was the only company in the world with the technology to quote this application, a high pressure (150 psig), high temperature (900 °F discharge) gas booster (four bearing outboard design) used in a continuous sulfur scrubbing operation. This “green” application helps a power plant utilize America’s most prevalent energy source, high sulfur coal. Unusual aspects: skid-mounted “turnkey” delivery with blower completely prewired and plumbed for installation convenience; combination of oil and grease bearing lubrication; rigid wiring conduit designed for hazardous locations; separate control panel for double mechanical seals; and water-cooled bearings.

One source for all needs

Spencer can supply whatever your air or gas handling project requires and integrate it into a smoothly functioning system. Every item we furnish will offer reliable performance and compatibility with other components, saving your engineering and purchasing departments time and effort.

“Plug-in” turnkey packages

We can provide complete blower packages — skid-mounted, prewired and plumbed systems including electrical controls, valves and all other system components. These packages are factory tested and ready for connection to your electrical, process piping and purge gas lines.

Choices of motors, drivers and drive arrangements

Spencer can supply AC and DC electric motors to comply with the most difficult, wide-ranging specifications including:

- Nuclear qualification
- Heavy-duty requirements
- 50 Hz, 60 Hz and other frequencies
- Special voltages
- Explosion-proof, chemical-resistant and other special designs
- Special lubrication provisions such as low outgassing fluorocarbon-based grease

However, your prime mover doesn’t have to be an electric motor. Spencer can provide steam turbines, gasoline and diesel engines, and other drivers powered by natural gas, propane or landfill gas.

You name whatever you need, and we’ll work with you to deliver it.

Special drive configurations are also easily arranged. You can specify a belt drive for blower operation at a certain speed, or variable frequency drive, or a drive train with a gearbox speed increaser — whatever your application requires.

API blowers and bases

Spencer can supply blowers and bases which comply with specific API standards for petrochemical plants and refineries.

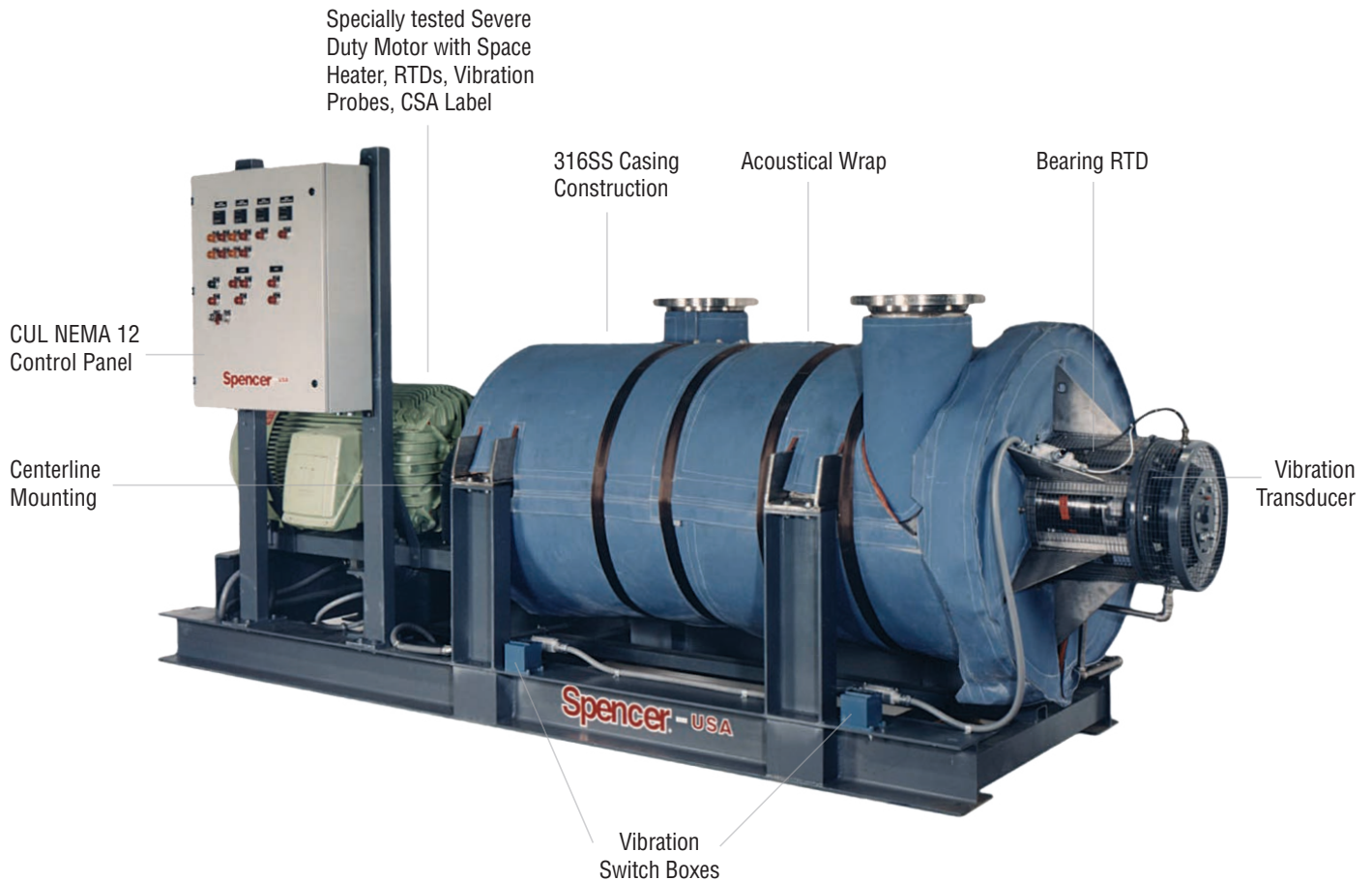

Spencer was the only bidder able to provide three gas booster/control packages for a uranium processing system. One package included this 250 hp four bearing outboard blower used to recover toxic fumes for purification. The corrosive conditions required 316SS extra-heavy construction with corrosion allowance. Unusual aspects: bearing vibration and temperature monitors with warning and shutdown alarms; water-cooled bearings with water flow failure alarms; Electronic Modulating Bleed Control (EMBC) for low flow recirculation protection; motor windings space heater to prevent condensation damage during shutdowns; connections of all electrical alarm and status indicators to the customer's Motor Control Center, and Programmable Logic Controllers.

Flexible couplings

Any type of coupling may be specified, including:

- Spacer
- Gear-type
- Diaphragm
- Elastomeric
- Non-lubricated

Centerline mounting

This optional support method for high temperature blowers helps maintain coupling and piping alignment and reduces stress on seals and bearings during thermal expansion.

Acoustical wrap

Any blower can be custom-fitted with an acoustical wrap for sound attenuation. Acoustical wraps also provide thermal insulation for high temperature blowers and protect personnel from touching hot blower surfaces. They are easily removed and reinstalled for blower maintenance.

Special vibration control

Each Spencer blower is balanced after assembly to a vibration tolerance appropriate for its design. When desired, we can use special balancing techniques to achieve a total amplitude of vibration at the bearing housings of less than one mil at 3600 RPM operation.

Other System Accessories

Flow switches

Butterfly and check valves

Temperature and pressure gauges

Expansion joints

Vibration isolating pads

Bypass heat exchangers

Recirculation systems for low flow conditions

Monitoring and Control Systems

Electrical control systems

Beyond basic start/stop functions, an electrical control system can monitor and adjust critical blower and process variables. If a blower or process cannot be maintained within established operational parameters, the control system can further provide alarm and shutdown functions.

Spencer makes 100% of its control systems, using our complete in-house capabilities for system design and construction. Control panels may be equipped with any desired level of sophistication including data acquisition instruments, remote process controls, multiple blower sequencers and other forms of control technology.

Blower protection options

Spencer offers many optional safety features that help protect your blower investment. Vibration, bearing temperature and low flow monitors, for example, alert personnel to potentially dangerous situations such as material buildup within the blower, a lack of bearing lubricant or an obstruction in the gas flow.

Blower and process monitors

Spencer monitoring systems incorporate sensors, transducers, gauges, alarms and shutdown circuitry to govern blower and process parameters such as:

- Blower bearing temperature
- Motor bearing temperature
- Motor winding temperature
- Blower inlet/outlet pressures
- Blower vibration
- Air or gas flow level
- Dissolved oxygen level
- Water flow to water-cooled bearings
- Purge gas flow to blower shaft seals
- Blower and motor loading (low loads and overloads)

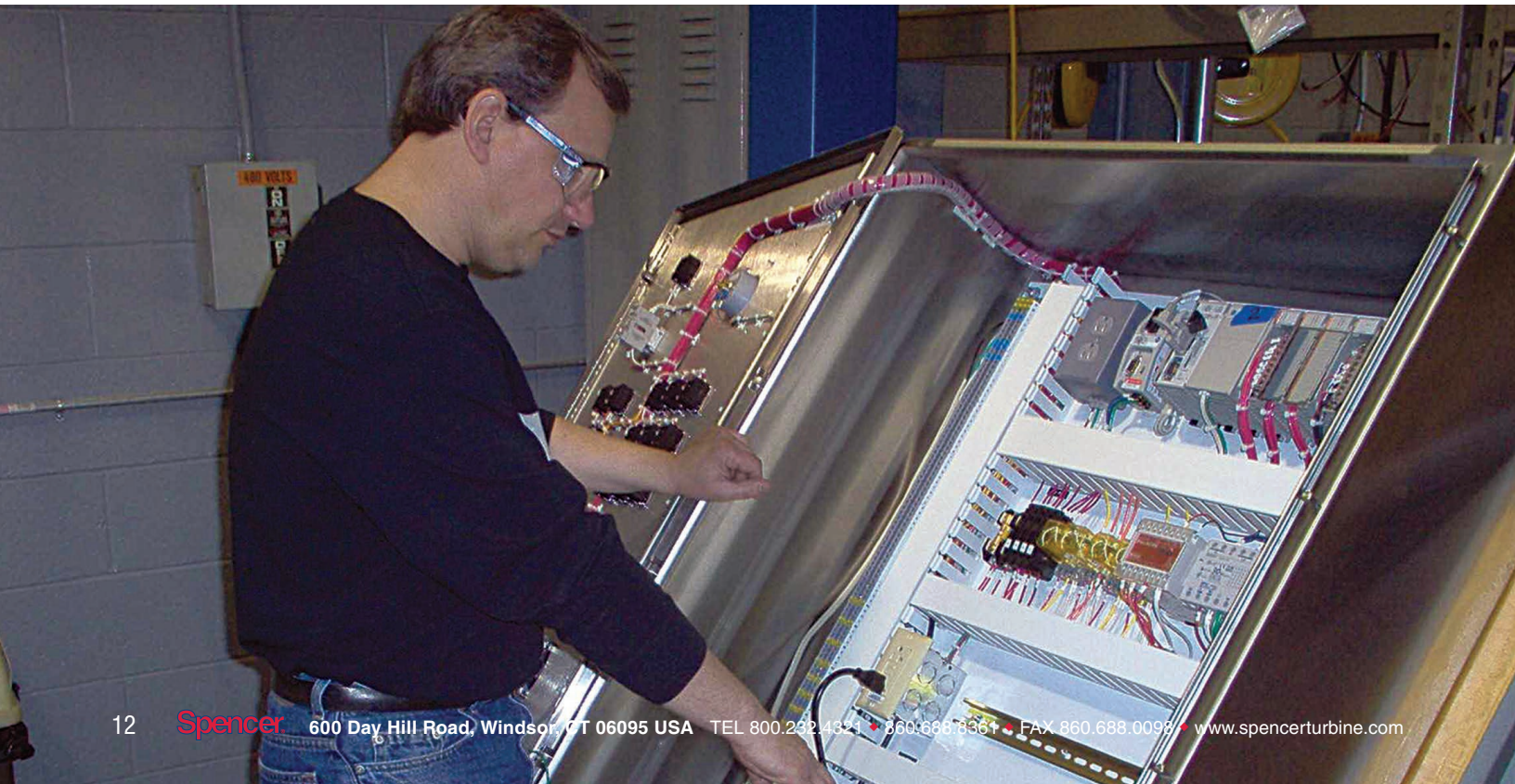



Temperature monitoring uses Resistance Temperature Detectors (RTDs) and digital display temperature controllers. The digital display includes temperature warning and shutdown set points, operating temperature and signal failure alarms.

Process automation features

To support process automation, Spencer can provide blowers and gas boosters with Programmable Logic Controllers and operator interface terminals.

Under PLC direction, machines in multiple-blower installations can be cycled on and off-line or sequenced in any pattern to equalize loading or respond to changing process demands. Communication links can be established from the PLC to any remote location – even to the Spencer factory via high-speed modem.

Supervisory control and data acquisition (SCADA) systems for factory automation

Spencer blower installations can be tied into SCADA systems for central control of an entire plant. Besides supplying the central system with blower status information, the Spencer control panel can interface with existing central alarm systems. Blower set points can be established and on/off commands issued remotely, for fast response to varying process conditions.

Universal control boards

A proprietary Spencer concept, universal controllers provide increased functionality and greater ease of blower operation. By designing these controls in-house, we have customized their performance specifically for Spencer gas boosters and blowers.

In a single module, the universal board can provide flow control, automatic bypass valve control, bearing temperature monitoring, overload and low-load safety control, and many additional features for operational precision or convenience.

The universal control has an RTD temperature control board that provides protection for two bearings in one controller, incorporating a warning alarm prior to the shutdown alarm.

The bypass system control of the universal board is unusually versatile. It offers manual valve operation capability from a central controller for intercooler operation to govern bypass gas temperature reduction.

Electronic modulating bleed control (EMBC)

For blowers that must operate at low flow levels, this is one of the most valuable Spencer control options. The EMBC system, which can be ordered as a function of the universal control board, provides bypass recirculation of gas so that a blower can operate at low flow without going into a potentially destructive surge condition.

EMBC set points are adjustable via a keypad on the universal panel, which will also display blower operation in either motor amps or CFM. This flexible system can be switched from automatic to manual operation at the keypad so that an operator can open and close the bypass valve by hand and determine the bypass set points.

UL/CUL Listed control panels

UL Listed Spencer control panels for the U.S. market are built in accordance with UL 508A standards for industrial control panels for general use. For Canada, Spencer panels comply with the requirements of CSA Standard for Industrial Control Equipment C22.2 No. 14-M91 and bear the CUL label.

Control system engineering and design assistance

Spencer engineers are available as a planning resource to help customers and Spencer representatives design new control systems that will accommodate all the desired functions.

For high-technology systems that incorporate operator interface terminals and PLCs, it is also desirable to have Spencer engineers provide field startup assistance.

What Are Your Application Requirements?

Consider these questions and our experts can help you identify your best solution.

What is the involved process?

What are the gas characteristics?

- Gas composition
- Volume/turndown
- Differential pressure
- Inlet temperature
- Inlet pressure

Is the gas hazardous, toxic, explosive, carcinogenic, flammable, corrosive or radioactive?

Is the gas expensive?

Certain gases such as argon must be protected from two-way leakage — no leakage out because it is expensive, no leakage in because it can't be contaminated.

How much leakage is permissible, in and out of the blower?

Consider whether leakage must be prevented in just one direction or both.

What is the most sensible sealing approach for this application?

Choose the appropriate seal for the application, considering maintenance costs as well as initial cost.

What is the duty cycle and the desired life expectancy of the blower?

For example, a pilot plant with a three-month life might use inexpensive coated blowers and discard them, rather than buying costly, long-life custom blowers using special alloys.

What is the budget for this blower?

Consider what tradeoffs in seals, materials and other features are acceptable.

What materials are required for this application?

Consider which materials will be used for process gas piping to and from the blower. Also bear in mind that Spencer offers three different ways to deal with corrosion:

- Extra-thick standard materials with built-in corrosion allowance
- Special coatings (page 9)
- Special materials of construction (page 9)

What are the ambient environmental conditions around the blower?

- Noise levels and restrictions
- Temperature
- Thermal cycling
- External corrosive risk from water vapor, acid fumes, etc.
- Altitude

Are there any applicable regulatory codes?

Are there any special quality control requirements?

Do you require special cleaning of the blower before delivery, to avoid process contamination?

Are there any special testing requirements? These are some examples: (any of which may be witness tests)

- Hydrostatic
- Halide leak
- Impeller overspeed
- Vibration
- Dye penetrant
- ASME PTC-10 Performance Test
- Octave band noise analysis

What accessory equipment and options do you require?

What electrical control considerations do you have?

Determine, for example, if the control panel should tie into a factory automation system or PLC.

Do you require a specific type of coupling between motor and blower?

Do you need special drive arrangements such as belt drive, variable frequency drive or an alternative driver such as a diesel engine?

For hermetic gas boosters, is the process gas compatible with the motor? Is the temperature low enough and the volume high enough to cool the motor?

Gas booster motors are sealed within the blower, where they must be cooled – but not damaged – by process gas flowing past continuously.



Spencer Corporate Headquarters and Manufacturing Plant, Windsor, CT USA

Backed by our reputation for legendary customer satisfaction, our solutions take on the 21st century

Our equipment solutions incorporate the latest in custom air and gas handling blowers and gas boosters, including single- and multistage centrifugal designs, energy-efficient cast machines, and hermetically sealed gas boosters. The diversity and breadth of our product line meet applications in the broadest range of markets, including chemical; petrochemical; mining; power; environmental; pulp and paper; food and beverage; pharmaceutical; and water and wastewater treatment.

Spencer Products and Services

Industrially rated products offering effective solutions for air and gas handling problems

- Custom-engineered blowers with special materials for extreme temperatures and pressures
- Gas boosters and hermetic gas boosters
- Multistage centrifugal blowers
- Single-stage centrifugal blowers
- Regenerative blowers
- Modular central vacuum systems
- Mobile or stationary integrated vacuum units
- Separators and dust collectors

Complementary accessories with single source convenience and compatibility

- Standard and custom electrical control panels – UL, CUL Listed and CE compliance available
- Valves, gauges, couplings, shrink sleeves, vibration isolators and other system components
- Comprehensive selection of tubing, fittings, vacuum hoses, valves and tools

Comprehensive engineering and other customer support services

- The industry's largest complement of technical specialists in air and gas handling technology
- Worldwide parts and service organization
- Application research and testing facility

Global organization offering

- Product selection, installation and operation assistance
- Comprehensive system design services
- Follow-up services and troubleshooting

Rely on Spencer's unique Engineering Edge to make your equipment special and your process work – no matter how demanding your requirements.

Note: Power Mizer® and Vortex® are registered trademarks of The Spencer Turbine Company.

Spencer[®]
Specials Are Our Standard

Custom Blowers and Gas Boosters For
Air and Gas Handling Applications

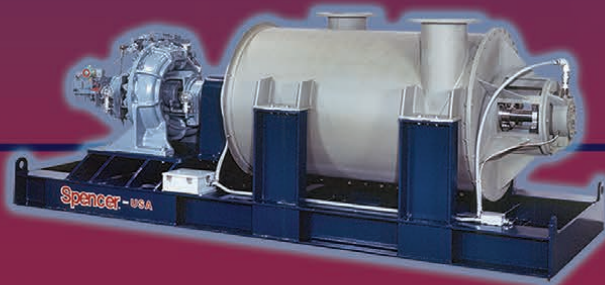
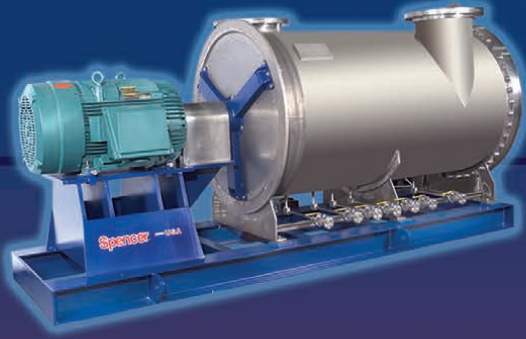

For product selection assistance, please email marketing@spencer-air.com
or visit our website at www.spencerturbine.com to locate the Spencer representative in your area.

The  **Spencer** Turbine Company, 600 Day Hill Road, Windsor, CT 06095 USA

TEL 800.232.4321 ♦ 860.688.8361 ♦ FAX 860.688.0098 ♦ www.spencerturbine.com



Bulletin No. 510E Copyright ©2018 The Spencer Turbine Company 061118KBA