



CryoDoser Flex® Liquid Nitrogen Dosing

The CryoDoser Flex® Liquid Nitrogen Dosing System is the first doser with the ability to serve every dosing application within one unit. Chart Inc. has designed a brand new dosing system that can be used from the slowest production lines to the fastest. The most efficient dosing system to date, the CryoDoser Flex system is the only liquid nitrogen doser you need. The CryoDoser Flex unit is offered with two controllers, the Craft Custom and the Pack Premier.

With two premium controller options, more standard functions than any other doser offered before, and a brand new all-around design, the CryoDoser Flex system is ready to change the market.

Features

- **Compact Size** – enables installation in limited spaces
- **Discrete Dosing** – Craft Custom (750 cpm) and Pack Premier (2000+ cpm)
- **SoftDose™ Compatible** – Chart's proven technology for hot fill, powder and granular applications
- **MicroDose™ Standard** – the Pack Premier has a controller function that allows dosing pressure adjustments
- **RemoteDose™ Standard*** – monitor, troubleshoot and make adjustments while connected to your VPN**
- **ExacTrack™** – with the new EDS (Electric Dosing System), supreme accuracy is achieved. Proportionally control the amount the actuator opens and make dosing duration changes in increments of 0.1 ms.
- **Warranty** – four (4) year vacuum warranty; highest in the industry one (1) year controller warranty

* Results achieved at Chart laboratory conditions.

** Access to the internal network is necessary for this function.



How it Works

LN₂ is supplied to the CryoDoser Flex unit by a vacuum insulated hose and flows into the dosing head. A sensor detects the speed of the line (encoder compatible); a second sensor detects the presence of a container. When a container is detected, the dosing head opens and dispenses an exact amount of pure LN₂. A PLC (Programmable Logic Controller) is the brains behind integrating the sensors, controls and human interface via a touch-screen HMI (Human Machine Interface) display.

Key Benefits

- **Lightweight PET** – reduce the weight of PET for cost and environmental savings
- **Glass to PET Transition** – eliminate glass safety hazards and weight of containers
- **Container Rigidity** – maintain shape even with lighter weight containers
- **Eliminate Paneling** – increase the internal pressure to offset paneling issues
- **Oxygen Reduction** – create an inert environment to preserve product freshness
- **Extend Shelf Life** – minimize oxygen levels
- **Ease of Labeling** – consistent container rigidity creates an efficient labeling process
- **Reduce Nitrogen Consumption** – measurable and repeatable liquid doses
- **Maximize Warehouse Storage Space** – increasing product stackability utilizes less square footage
- **Stabilize Organic Products** – extend shelf life without preservatives



CryoDoser Flex[®] Technical Specifications



Materials	All 316L Stainless Steel
Weight	33 lbs (15 kg)
Body Dimensions	21" H x 6.5" W (533.4 x 165 mm)
Dosing Head Dimensions	DoserEASE = 11" H (279 mm) / EDS = 18.5" H (470 mm)
Arm Reach	12.5" to 20.5" (317.5 to 520.7 mm)
Head Pressure	0.34 psi (0.023 bar)
Nozzles	Ships with 3 Standard Nozzles: 0.020" - 0.100" (0.005" increments) available
System Utilities	Liquid Nitrogen: 5 - 125 psi (0.34 - 8.6 bar) Gaseous Nitrogen: 60+ psi (4.1+ bar) for Purge Electricity: 110 - 240VAC; 50/60Hz, 110W
Steady State Consumption	0.035 gal (0.13 liters) / hour
Vacuum Insulated	Yes
Interchangeable Arms	Yes
Fill Level Adjustment	Yes

CryoDoser Flex[®] Dimensions

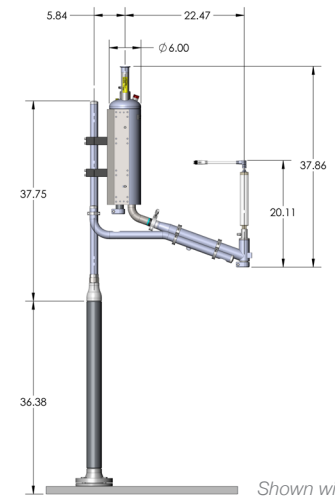

Shown with EDS

Controller Technical Specifications

Model	Pack Premier	Craft Custom
PLC Platform	Siemens S7-1200	Siemens S7-1200
Display	7" (178 mm) TFT Color LCD Touch Screen	4.3" (109 mm) TFT Color LCD Touch Screen
Dose Actuator	DoserEASE or EDS	DoserEASE
Dose Duration min/max	5 ms/Unlimited	15 ms/1 s
Dose Duration Resolution	0.1 ms	1 ms
Dose Volume	0.002 to 14 grams/dose	0.002 to 14 grams/dose
Discrete Dosing cpm (cph) min/max	1/2,500* (60/150,000)	30/750* (1,800/45,000)
ExacTrack*	✓	
Electronic Dose Targeting	✓	
Container Detection	✓	✓
Fixed Delay Mode w/ Step	✓	✓
Accuracy	± 2% of dose weight	± 2% of dose weight
Multiple Languages	✓	✓
MicroDose™ Technology	✓	✓
RemoteDose™ Capable**	✓	
SoftDose™ Capable	✓	
IntelliDose™ Capable*	✓	
User Sensor Interface	✓	
User Signal Interface	✓	
User Ethernet Interface	✓	
User USB Interface	✓	✓
Recipe Storage	Unlimited	4
Liquid Level Control	✓	✓
Liquid Supply Pressure psi (bar)	20 - 150 (1.37 - 10.34)	20-150 (1.37 - 10.34)
Standard Purge	✓	✓
ThermoPurge	Optional	Optional
System Service	Manual/Automated	Manual
System Diagnostics	Realtime	Static
Certifications	UL, CE, IP67, NEMA 4X	UL, CE, IP67, NEMA 4X

* Results achieved at Chart laboratory conditions. ** Access to the internal network is necessary for this function.

Your Local Representative



Chart Inc.

46441 Landing Parkway • Fremont, CA 94538

Phone +1 800.371.3303 • Fax +1 408.577.1567 • Service +1 408.371.4932

www.chartdosers.com

© 2018 Chart Inc.

PN 21119132