



Product Manual

Perma-Cyl® MicroBulk Storage System

1500 ZX VHP



Designed and Built by:

Chart Inc.

1300 Airport Dr.

Ball Ground, GA 30107 USA

(800) 400-4683



Contents

Revision Log	iv
Preface	1
General	1
Product Highlights.	1
Product Manual	1
Terms	2
Acronyms / Abbreviations.	2
Safety	3
General	3
Safety Bulletin.	3
Oxygen Deficient Atmospheres	4
Oxygen Cleaning	4
Oxygen Enriched Atmospheres	5
Nitrogen and Argon	5
Personal Protective Equipment (PPE).	5
Introduction	7
Tank Design	7
System Design.	7
Responsibilities	7
Handling the Perma-Cyl 1500 ZX VHP Cylinder.	8
Shipping the Perma-Cyl 1500 ZX VHP Cylinder.	8
Operation	9
Initial Inspections	9
First Fill/Purge Procedure, ASME.	9
Purging and First Fill Procedure	9
Filling the Tank After the Cool Down Process is Complete	10
Primary Plumbing Circuits	11
Fill	11
Pressure Build	11
Economizer	11
Liquid Use	11
Gas Use	11
Safety Circuit	12
Vent/Full Trycock.	12
Other Piping Circuits and Components	12
Phase Lines and Liquid Level Gauges	12
Four-Way Valve.	13
Pressure Gauge	13
Calibration Chart	14
Troubleshooting	15
Maintenance.	21
Bench Setting a Pressure Building Regulator	21
Bench Setting an Economizer Regulator	21
Rebuilding the Rego Operational Valves	21
Specifications	23
Flow Diagram	24
Controls and Function.	24
EXT PB Circuit - Top Components	25
EXT Gas Use Components	25
EXT PB Circuit - Bottom Components	26

External Vaporizer Components 27
Safety Components 28
FlexFill™ Piping Option Components 29
Economizer Components 30
Warranty 31
Chart Packaged Gas Products Warranty Policy 31

Revision Log

Revision Level	Date	Description
A	11/24/2015	Original product manual



Preface

General

The Perma-Cyl 1500 ZX VHP MicroBulk Storage Systems are designed and built with a rugged internal support system for mobility full of liquid within its protective metal pallet. The Perma-Cyl 1500 ZX VHP cylinder features a top and bottom fill system with an internal ullage tank. The internal ullage tank design allows for a single hose, ventless delivery with auto shutoff when filled with a Chart Orca™ MicroBulk Delivery vehicle. With the on-board external aluminum heat exchanger, the Perma-Cyl 1500 ZX VHP cylinder is rated at a flow rate of 3000 SCFH while sustaining 420 to 450 psig. The vessel is bolted to a dedicated metal pallet for full protection and transportability with an overhead crane or forklift. The portable design makes the Perma-Cyl 1500 ZX VHP cylinder the ideal quick-response solution for demanding industrial gas applications, like laser-assist gas.

Product Highlights

- Perma-Cyl system is equipped with top and bottom fill (FlexFill™ Piping Option) for accurate pressure control during delivery.
- High flow external aluminum vaporizer and pressure builder system provides up to 3000 SCFH at 420 to 450 psig
- Separate pressure build and economizer regulators with isolation valves
- Dual relief valves and rupture discs with diverter valve
- Provides safe, single hose, no loss, auto shutoff fill when filled with Orca MicroBulk Delivery System
- Metal pallet incorporates forklift slots while protecting plumbing and tank during transportation and application use
- Pallet has durable exterior coating for maximum corrosion resistance

Product Manual

This product manual describes the specifications, installation, operation and maintenance of the Perma-Cyl 1500 ZX VHP cylinder model. Included within this manual is information regarding the safe operation and handling of liquid nitrogen, argon, and oxygen within the cylinder. It should be thoroughly read and understood by anyone that operates the equipment. If there are any questions regarding the operation of the Perma-Cyl 1500 ZX VHP cylinder, contact Chart Technical Service at 800-400-4683.

The schematic, piping illustrations and parts list in the Specifications section show a reference number for each component used on the cylinders. The reference numbers will be used throughout this manual to draw specific attention to a component while describing its function, operation, or repair.

The safety requirements for operating the tank and handling or transporting extremely cold liquid products are shown in the Safety section. Use this safety section as a “Safety Checklist” each time the equipment is being used.

The Introduction section discusses the general design of the tank and outlines the responsibilities of the distributor and the filler of the tank. Information on handling the tank and shipping is also included in this section.

In the Operation section there is information on the initial inspection, purging the tank, filling the tank, and gas and liquid withdrawal. This section also includes specifications and calibration charts.

The Troubleshooting section contains a table of issues and remedies that may arise in the use of the Perma-Cyl 1500 ZX VHP cylinder.

Please refer to the Maintenance section for general maintenance instructions and identification of various parts on the Perma-Cyl 1500 ZX VHP cylinder.

Terms

Throughout this manual safety precautions will be designated as follows:



Warning! *Description of a condition that can result in personal injury or death.*



Caution! *Description of a condition that can result in equipment or component damage.*



Note: *A statement that contains information that is important enough to emphasize or repeat.*

Acronyms / Abbreviations

The following acronyms / abbreviations are used throughout this manual:

Ar	Argon
ASME	American Society of Mechanical Engineers
BAR	Pressure (Metric)
CGA	Compressed Gas Association
DOT	Department of Transportation
H ₂ O	Water
Kg	Kilogram
LAR	Liquid Argon
LIN	Liquid Nitrogen
LOX	Liquid Oxygen
N ₂	Nitrogen
NFPA	National Fire Protection Association
O ₂	Oxygen
PB	Pressure Builder
PN	Part Number
PSI	Pounds per Square Inch
PSIG	Pounds per Square Inch (Gauge)
SCFH	Standard Cubic Feet/Hour

Safety

General

While Chart equipment is designed and built to the most rigid standards, no piece of mechanical equipment can ever be made 100% foolproof. Strict compliance with proper safety and handling practices are necessary when using a cryogenic manifold device or other compressed gas equipment. We recommend that all of our customers re-emphasize safety and safe handling practices to all their employees and customers. While every possible safety feature has been designed into the Perma-Cyl 1500 ZX VHP cylinder and safe operations are anticipated, it is essential that the customer carefully read and fully understand all Warning and Caution notes listed below.



Warning! *Excess accumulation of oxygen creates an oxygen enriched atmosphere (defined by the Compressed Gas Association as an oxygen concentration above 23 percent). In oxygen enriched atmospheres flammable items burn vigorously and could explode. Certain items considered noncombustible in air may burn rapidly in such an environment. Keep all organic materials and other flammable substances away from possible contact with oxygen; particularly oil, grease, kerosene, cloth, wood, paint, tar, coal, dust and dirt which may contain oil or grease. DO NOT permit smoking or open flames in any area where oxygen is stored, handled or used. Failure to comply with this warning may result in personal injury.*



Warning! *Nitrogen and argon vapors in air may dilute the concentration of oxygen necessary to support or sustain life. Exposure to such an oxygen deficient atmosphere can lead to unconsciousness and serious injury, including death.*



Warning! *Before removing cylinder parts or fittings, completely empty the liquid cylinder of liquid and release the entire vapor pressure in a safe manner. External valves and fittings can become extremely cold and may cause painful burns to personnel unless properly protected. Personnel must wear protective gloves and eye protection whenever removing parts or loosening fittings. Failure to do so may result in personal injury because of the extreme cold and pressure in the cylinder.*



Caution! *Only use replacement equipment which is compatible with liquid oxygen and has been cleaned for oxygen use. Do not use regulators, fittings, hoses, etc., which have been previously used in compressed air service. Failure to comply with these instructions may result in serious damage to the liquid cylinder and personal injury.*



Caution! *The Perma-Cyl 1500 ZX VHP cylinder should be moved using a fork truck that lifts the cylinders from beneath the pallet. The Perma-Cyl 1500 ZX VHP cylinder must be used and stored in a vertical position. Do not lay, store, or ship a liquid cylinder on its side. Failure to comply with these procedures may result in damage to the liquid cylinder.*

Safety Bulletin

Portions of the following information are extracted from Safety Bulletin SB-2 from the Compressed Gas Association, Inc. Additional information on oxygen, nitrogen, argon, and cryogenics is available from the CGA (www.cganet.com).

Cryogenic containers, stationary or portable, are from time to time subjected to assorted environmental conditions of an unforeseen nature. This safety bulletin is intended to call attention to the fact that whenever a cryogenic container is involved in any incident whereby the container or its safety devices are damaged, good safety practices must be followed. The same holds true whenever the integrity or function of a container is suspected of abnormal operation.

Incidents which require that such practices be followed include: highway accidents, immersion of a container in water, exposure to extreme heat or fire, and exposure to most adverse weather conditions (earthquake, tornadoes, etc.). Under no circumstances should a damaged container be left with product in it for an extended period of time.

Prior to reusing a damaged container, the unit must be tested, evaluated, and repaired as necessary. It is highly recommended that any damaged container be returned to Chart for repair and re-certification.

In the event of known or suspected container vacuum problems (even if extraordinary circumstances such as those noted above have not occurred), do not continue to use the unit. Continued use of a cryogenic container that has a vacuum problem can lead to embrittlement and cracking.

The remainder of this safety bulletin addresses those adverse environments that may be encountered when a cryogenic container has been severely damaged. These are oxygen deficient atmospheres, oxygen enriched atmospheres, and exposure to inert gases.



Caution! Before locating oxygen equipment, become familiar with the NFPA standard No. 55 “Compressed Gases and Cryogenic Fluids Code” (www.nfpa.org) and with all local safety codes.

Oxygen Deficient Atmospheres



Warning! Nitrogen and argon vapors in air may dilute the concentration of oxygen necessary to support or sustain life. Exposure to such an oxygen deficient atmosphere can lead to unconsciousness and serious injury, including death.

The normal oxygen content of air is approximately 21%. Depletion of oxygen content in air, either by combustion or by displacement with inert gas, is a potential hazard and users should exercise suitable precautions.

One aspect of this possible hazard is the response of humans when exposed to an atmosphere containing only 8 to 12% oxygen. In this environment, unconsciousness can be immediate with virtually no warning.

When the oxygen content of air is reduced to about 15 to 16%, the flame of ordinary combustible materials, including those commonly used as fuel for heat or light, may be extinguished. Somewhat below this concentration, an individual breathing the air is mentally incapable of diagnosing the situation because the onset of symptoms such as sleepiness, fatigue, lassitude, loss of coordination, errors in judgment and confusion can be masked by a state of “euphoria,” leaving the victim with a false sense of security and well being.

Human exposure to atmosphere containing 12% or less oxygen leads to rapid unconsciousness. Unconsciousness can occur so rapidly that the user is rendered essentially helpless. This can occur if the condition is reached by an immediate change of environment, or through the gradual depletion of oxygen.

Most individuals working in or around oxygen deficient atmospheres rely on the “buddy system” for protection - obviously the “buddy” is equally susceptible to asphyxiation if he or she enters the area to assist the unconscious partner unless equipped with a portable air supply. Best protection is obtainable by equipping all individuals with a portable supply of respirable air. Life lines are acceptable only if the area is essentially free of obstructions and individuals can assist one another without constraint.

If an oxygen deficient atmosphere is suspected or known to exist:

1. Use the “buddy system.” Use more than one “buddy” if necessary to move a fellow worker in an emergency.
2. Both the worker and “buddy” should be equipped with self-contained or airline breathing equipment.

Oxygen Cleaning

When replacing components, only use parts which are considered compatible with liquid oxygen and have been properly cleaned for oxygen service (Refer to CGA Bulletin G-4.1 “Equipment Cleaned for Oxygen Service”). Do not use regulators, fittings, or hoses which were previously used in a compressed air environment on these tanks. Only oxygen compatible sealants or Teflon tape should be used on threaded fittings. All new piping joints should be leak tested with an oxygen compatible leak-test solution.

Oxygen Enriched Atmospheres

An oxygen-enriched atmosphere occurs whenever the normal oxygen content of air is allowed to rise above 23%. While oxygen is nonflammable, ignition of combustible materials can occur more readily in an oxygen-rich atmosphere than in air; and combustion proceeds at a faster rate although no more heat is released.

It is important to locate an oxygen system in a well ventilated location since oxygen-rich atmospheres may collect temporarily in confined areas during the functioning of a safety relief device or leakage from the system.

Oxygen system components, including but not limited to, containers, valves, valve seats, lubricants, fittings, gaskets and interconnecting equipment including hoses, shall have adequate compatibility with oxygen under the conditions of temperature and pressure to which the components may be exposed in the containment and use of oxygen. Easily ignitable materials shall be avoided unless they are parts of equipment or systems that are approved, listed, or proven suitable by tests or by past experience.

Compatibility involves both combustibility and ease of ignition. Materials that burn in air may burn violently in pure oxygen at normal pressure, and explosively in pressurized oxygen. In addition, many materials that do not burn in air may do so in pure oxygen, particularly when under pressure. Metals for containers and piping must be carefully selected, depending on service conditions. The various steels are acceptable for many applications, but some service conditions may call for other materials (usually copper or its alloy) because of their greater resistance to ignition and lower rate of combustion.

Similarly, materials that can be ignited in air have lower ignition energies in oxygen. Many such materials may be ignited by friction at a valve seat or stem packing, or by adiabatic compression produced when oxygen at high pressure is rapidly introduced into a system initially at low pressure.



Warning! If clothing should be splashed with liquid oxygen it will become highly flammable and easily ignited while concentrated oxygen remains. Such clothing must be aired out immediately, removing the clothing if possible, and should not be considered safe for at least 30 minutes.

Nitrogen and Argon

Nitrogen and argon (inert gases) are simple asphyxiates. Neither gas will support or sustain life and can produce immediate hazardous conditions through the displacement of oxygen. Under high pressure these gases may produce narcosis even though an adequate oxygen supply sufficient for life is present.

Nitrogen and argon vapors in air dilute the concentration of oxygen necessary to support or sustain life. Inhalation of high concentrations of these gases can cause anoxia, resulting in dizziness, nausea, vomiting, or unconsciousness and possibly death. Individuals should be prohibited from entering areas where the oxygen content is below 19% unless equipped with a self-contained breathing apparatus. Unconsciousness and death may occur with virtually no warning if the oxygen concentration is below approximately 8%. Contact with cold nitrogen or argon gas or liquid can cause cryogenic (extreme low temperature) burns and freeze body tissue.

Persons suffering from lack of oxygen should be immediately moved to areas with normal atmospheres. **SELF-CONTAINED BREATHING APPARATUS MAY BE REQUIRED TO PREVENT ASPHYXIATION OF RESCUE WORKERS.** Assisted respiration and supplemental oxygen should be given if the victim is not breathing. If cryogenic liquid or cold boil-off gas contacts worker's skin or eyes, the affected tissue should be flooded or soaked with tepid water (105-115°F or 41-46°C). **DO NOT USE HOT WATER.** Cryogenic burns that result in blistering or deeper tissue freezing should be examined promptly by a physician.

Personal Protective Equipment (PPE)

The following personal protective equipment is recommended when working around cryogenic liquid:

- Safety glasses with side shields to prevent cryogenic liquid from splashing into the eyes
- Chemical / Liquid resistant gloves to prevent cryogenic burns on exposed hands
- Long sleeve shirts to protect the arms
- Cuffless trousers worn over closed shoes

Introduction

Tank Design

The Perma-Cyl 1500 ZX VHP cylinder is a vacuum insulated cylinder that is designed to furnish liquid and gaseous oxygen, nitrogen or argon on a reliable, economical basis. The tank holds 1500 liters of cryogenic product. The tank is pressure rated at 500 psig and has both internal and external pressure build and process vaporizers.

The insulation system is comprised of multiple layers of foil and paper that are incorporated with a very low vacuum. The vacuum is factory sealed and with the aid of internal molecular sieve it should remain low for the life of the container. This insulation system coupled with design of the support system minimizes the pressure rise when the tank is left idle. If product is left in the container for a period of time, the pressure will build and eventually vent through the safety relief valve. However, if the container is used in gas withdrawal service after pressure has built, the economizer system will automatically reduce the head pressure in the container without loss of product.

The design and construction of the Perma-Cyl 1500 ZX VHP cylinder is aimed at building the most durable tank available today. The inner vessel is constructed of stainless steel and designed to the applicable pressure vessel code. The outer container is constructed of stainless steel to make the Perma-Cyl 1500 ZX VHP cylinder a maintenance free container. The unit is mounted on a painted carbon steel pallet frame.

The inner pressure vessel is protected from over-pressurization by a safety relief valve. The Perma-Cyl 1500 ZX VHP cylinder pressure is set at 500 psig with a rupture disc set at 700 psig. The outer container of vacuum space is protected by a reverse buckling rupture disc that is set at a maximum of 25 psig.

System Design

The Perma-Cyl 1500 ZX VHP MicroBulk Storage System cylinder is the newest addition to the Perma-Cyl family of liquid cylinders, designed for high pressure, high flow industrial gas applications. With the on-board, heat-exchanger system, the Perma-Cyl 1500 ZX VHP cylinder is rated at a flow rate of 3000 SCFH while sustaining 420 to 450 psig. Flows over 3000 SCFH can be achieved with reduced duty cycles and added vaporization.

The Perma-Cyl 1500 ZX VHP cylinder is contained completely within a 61.8" deep x 61.8" wide x 92.8" high pallet. The pallet system can be moved by fork truck. The portable design makes it a quick-response solution for demanding industrial gas applications, such as industrial laser-assist gas.

The piping uses industry proven valves and components. The operation of the system is simple and is modeled after a standard liquid cylinder.

Responsibilities

The responsibilities of the Distributor and the Filler of the Perma-Cyl 1500 ZX VHP cylinder are stated below:

1. The cylinder must be in a safe condition before filling.

The filler is responsible for confirming that the Perma-Cyl 1500 ZX VHP to be filled is in its proper working condition. This includes:

- Has an ASME Data Plate
- An appropriately sized and marked primary relief valve
- There is no visible structural damage to the cylinder
- All required labeling is in place and legible

2. Do not overfill.

The Perma-Cyl 1500 ZX VHP cylinder is not to be filled beyond the recommended filling limits described in this manual.

3. Dispense only to knowledgeable users.

The filler must determine that the user is knowledgeable about the general characteristics of the product and proper safety precautions for its use.

4. Dispose of cylinders properly.

To eliminate the risk of injury from the improper reuse of cryogenic (vacuum jacketed) cylinders, before disposal, destroy the cylinder's pressure retaining capability.

We Recommend:

- Purge the cylinder's contents.
- Drill multiple holes through the cylinder and its vacuum casing or otherwise puncture the inner vessel. Make sure this is done before the scrap dealer takes possession.

Handling the Perma-Cyl 1500 ZX VHP Cylinder

The Perma-Cyl 1500 ZX VHP storage vessel is mounted on a painted carbon steel pallet. The preferred handling method is a forklift that lifts the pallet-mounted tank from beneath the pallet. Lifting of the Perma-Cyl 1500 ZX VHP cylinder should be performed only with equipment rated for the weight of the cylinder, pallet and contents combined (see Specifications section of this manual).

This container should remain upright at all times. Never lay the unit on its side to move or transport it. Careless handling can cause damage to the support system and internal plumbing, which may result in serious personal injury.

Shipping the Perma-Cyl 1500 ZX VHP Cylinder

The Perma-Cyl 1500 ZX VHP has a pressure strengthened inner vessel. It is not permitted to ship this tank with product in it.



Operation

Initial Inspections

When the container is first received it should be inspected for shipping damage. Never fill a damaged container.

The Perma-Cyl 1500 ZX VHP cylinder is shipped with nitrogen gas. For this reason any container that is to be put into oxygen or argon service should be thoroughly purged with the applicable gas.

First Fill/Purge Procedure, ASME



Note: *The Perma-Cyl 1500 ZX VHP cylinder is shipped with nitrogen gas. Purging is necessary prior to filling. During first fill, only fill the vessel to 75% full to allow for liquid expansion experienced with a new (warm) tank. Each fill thereafter can be filled to 100% full. All valves on an empty Perma-Cyl cylinder should always be kept closed to prevent the inner vessel and plumbing from being contaminated.*

Purging and First Fill Procedure

1. Attach the source of liquid purge to the fill connection of the Perma-Cyl 1500 ZX VHP cylinder.
2. If the fill hose has not been kept under pressure since the last delivery, it will need to be purged. Purge the fill hose and connector through the purge valve, if so equipped, or by loosening the fill connection until vapor flows from the connection and then retighten. Use the hose drain on the tank piping if equipped as such.
3. If the Perma-Cyl 1500 ZX VHP is pressurized, open the vent valve and blow down to 5 psi. To prevent drawing atmospheric contaminants back into the tank during the purging operation, a positive pressure of at least 5 psig should be maintained in the tank.
4. Partially fill the Perma-Cyl 1500 ZX VHP with 3000 standard cubic feet of product.

Let liquid build pressure close to safety setting.

Leak check all plumbing circuits while the tank is under maximum pressure.

While vent gas is still warm and tank is under pressure, move the four-way valve to the 'Equalization' position and loosen the fittings on either side of the liquid level

gauge to allow the gauge lines to purge with gas. Check the gas stream coming out of the fittings for evidence of moisture. Continue to flow the gas until lines have been purged and there is no visible signs of moisture. Tighten fittings to stop the flow of gas. Move the four-way valve to the 'Normal Operation' position.

Vent all product out of the liquid valve and close before pressure drops below 5 psig.

5. Fill the Perma-Cyl ZX VHP with 3000 standard cubic feet of product. Primarily use the bottom fill on a FlexFill piping option tank. Make sure some product is also routed through the top fill lines to purge them prior to totally filling the tank.

Open the PB circuit and set to maximum psi. Insure liquid is flowing through this circuit as indicated by frosting on the pipes. Let liquid in the tank build pressure close to safety setting. Once desired pressure is reached, open liquid valve. When liquid is out of the tank and pressure is still high, open the vent and gas use valves.

If a final line manifold is already connected to the gas use valve, purge through the manifold to ensure that there is a flow through the gas use circuit and any moisture is purged out before liquid is introduced into this circuit.

Once pressure is blown down to approximately 5 psig, close the liquid, vent and gas use valves.

6. Fill the Perma-Cyl ZX VHP cylinder with 3000 standard cubic feet of product and let the liquid in the tank build pressure close to the safety setting. Insure the product is flowing through and purging the economizer lines. Control the pressure by opening the gas use and vent valves. Once pressure is blown down to 5 psig, close the gas use and vent valves.
7. Fill the Perma-Cyl ZX VHP with 3000 standard cubic feet of product and let the liquid in the tank build pressure close to the safety setting. Once the desired psig has been reached, open the gas use and vent valves. Once pressure is blown down to 5 psig, close the gas use and vent valves.



Note: *The purge gas should be cooling the tank. If the tank vent line is HOT, always purge until the vent line is cool or even frosted. A new, warm tank should go through a minimum of four or five purge cycles before filling with liquid.*

Filling the Tank After the Cool Down Process is Complete

1. If equipped with a bottom fill valve, the bottom fill valve and the tank vent valve are the valves to be used to fill a warm tank.
2. Have the driver start the pump and slowly deliver the liquid into the tank. Observe the tank pressure and control the pressure by venting the tank down or using the top fill valve to control the pressure.

3. As the filling proceeds and the tank gets cooler, you should be able to pinch off and, in some cases, close the vent valve. We recommend that you do not fill the tank to the full trycock on the first fill. Fill to 75% in order to allow for liquid expansion as the tank contents absorb heat while the metal continues to cool down over time.



Caution! Pressure should be allowed to escape from the transfer hose before it is completely removed. A hose drain and relief valve should be installed in all transfer lines.

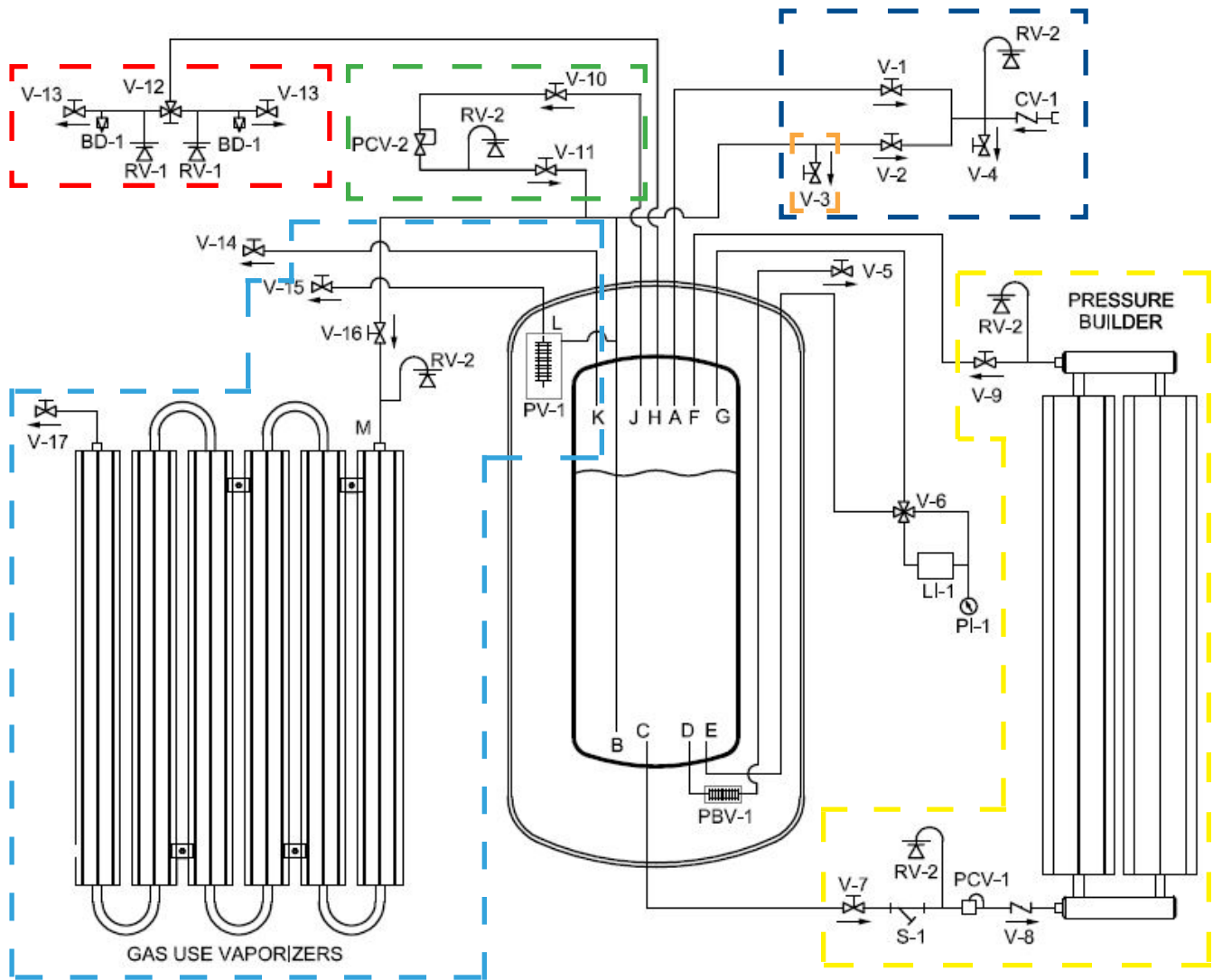

Color Code:
 Relief Circuit
 Liquid Use Circuit
 Fill Circuit
 PB Circuit
 Economizer Circuit
 Gas Use/Final Circuit

Figure 1 - Schematic for 1500 VHP Flex Fill

Primary Plumbing Circuits (Refer to Figure 1)

Fill

The Perma-Cyl w/ FlexFill has a top and bottom fill circuit so the driver can control the tank pressure while filling the Perma-Cyl MicroBulk Storage System. The fill circuit consists of a top fill valve (V-1), a bottom fill valve (V-2), a fill check valve (CV-1), and a hose drain valve (V-4). The fill line check valve has a service fitting on the inlet side that provides the sole connection for the liquid delivery vehicle.

The hose drain valve (V-4) can be used to both purge the fill hose before filling the tank or to depressurize the fill hose after filling the tank.

The driver controls the pressure in the vessel during the fill process by adjusting the flow through the top and bottom fill valves. Product flowing into the bottom of the tank will raise the pressure and product flowing into the top of the tank will lower the pressure. Adjusting each valve properly will allow the driver to hold a consistent pressure in the tank throughout the entire delivery.

During a first fill, only fill the vessel to 75% full to allow liquid expansion experienced with a new "hot" tank. Each fill there after can be filled to 100% full. Please refer to the Installation section of this manual for detailed filling procedures.



Caution! *If liquid can be trapped in the transfer system, a suitable relief valve must be installed to prevent over pressurization.*



Caution! *Before making a liquid transfer either into or out of this vessel, be sure that protective eyeglasses and gloves are being worn. If the transfer is being made to an open top vessel, the transfer pressure should be as low as possible and a phase separator should be used to eliminate splashing and hose whip.*

Pressure Build

The pressure build circuit is used to build pressure back in the vessel after a delivery or to maintain pressure as liquid is withdrawn from the vessel. The vessel pressure is set by adjusting the PB regulator (PCV-1). Standard PB set point is 450 psig.

As the tank pressure drops below the PB set point, the regulator opens and allows liquid to flow off the bottom of the tank, through the PB vaporization coils, and back into the gas phase of the tank. The pressure build circuit can be isolated by closing valve V-7 and V-9.

Economizer

The economizer circuit allows for the customer to utilize the natural heat leak that occurs in every cryogenic storage vessel. When the pressure is above the setpoint of the economizer regulator, the economizer regulator (PCV-2) opens. This allows gas to be withdrawn directly off the headspace of the tank and travel through the vaporization coils, in order to warm the cold gas, and out the gas use valve. This will result in lowering the pressure of the tank. Valves V-10 and V-11 can be used to isolate the economizer regulator.



Note: *The economizer circuit will only work if the customer is using product out of the vessel.*

Liquid Use

The liquid use circuit can be used for both a liquid application or a high flow gas use application. This circuit draws liquid directly up the dip tube and out through the liquid use valve (V-3).

Gas Use

The gas use valve leverages either the internal or external vaporizer on the Perma-Cyl system to supply gaseous product to the end user. Gas use valve V-15 is tied to the internal process vaporizer. Gas use valve V-17 is tied to the external process vaporizer.

The internal and external vaporizers can support specific flow rates. Flow is limited when used at the same time. The line size connected to the gas use should be sized properly for the pressure and flow rate that is desired.

The Perma-Cyl tank will deliver gas at various flow rates and temperatures for different applications. The equipment that is being supplied gas from the Perma-Cyl tank controls the flow rate. Higher flow rates may provide very cold gas that could damage the equipment to which they are attached. To supply gaseous product, follow this step by step procedure.

1. Connect the proper regulator/regulating manifold to the liquid cylinder's gas use outlet.

2. Connect the proper piping between the final line regulator and the receiving equipment.
3. Open the pressure building valve (V-7, V-9).
4. Allow pressure to build to the operating pressure (refer to gauge).
5. Open the gas use valve (V-17 or V-15).
6. Adjust the gas use regulator for the proper delivery pressure.



Caution! All valves on an empty Perma-Cyl tank should always be kept closed to protect the inner vessel and plumbing from being contaminated.

The operator should review the safety precautions found in the Safety section before conducting a gas or liquid withdrawal operation. Protective eyeglasses and gloves should always be worn.

At low flow rates, the Perma-Cyl tank is capable of delivering warm gas through the line regulator. As the flow rate increases, the temperature of the gas decreases. If the cold temperature becomes a problem at a desired flow rate, an additional external vaporizer can be added. Attach this vaporizer directly in series with the gas use connection and place the line regulator at the exit of the vaporizer.

Safety Circuit

The Perma-Cyl tanks with FlexFill are equipped with dual spring operated relief valves (RV-1) and dual burst discs (BD-1). The dual safety manifold with diverter valve (V-12) is standard on these vessels. This allows for change out of safety relief devices without the need to empty the tank. These devices are used to automatically relieve excess pressure in the vessel and cannot be isolated by use of a valve. Replacement of these relief devices should only be on a "like for like" basis. Substitutes should be avoided unless approved by the manufacturer. Purge valves (V-13) can be used to relieve pressure before repairing safety valves.

Vent/Full Trycock

The vent valve is used to relieve excess pressure in the cylinder. On Perma-Cyl systems the vent valve is a gray handled globe valve (V-14). When installed indoors, the vent line should be piped outdoors using 1/2" nominal copper or the equivalent stainless steel hose. The vent valve also serves as the full trycock during filling operations. When the Perma-Cyl tank is filled by trucks other than Orca™ MicroBulk

Delivery System trucks, the full trycock must be used to fill the vessel. When liquid starts to spit out of this valve while being filled, the filling process should be terminated.

Other Piping Circuits and Components

Phase Lines and Liquid Level Gauges

The Perma-Cyl tank is equipped with both a low pressure phase line located on the top of the vessel (G) and a high pressure liquid phase line located on the bottom of the vessel (E). These lines are connected to a differential pressure gauge (LI-1) which is used to indicate the amount of product in the vessel. The standard DP gauge used by Chart is the Cyl-Tel® Liquid Level Gauge. Customers can specify other models as options such as the WIKA Analog DP Gauge (see photos 1 & 2 below).

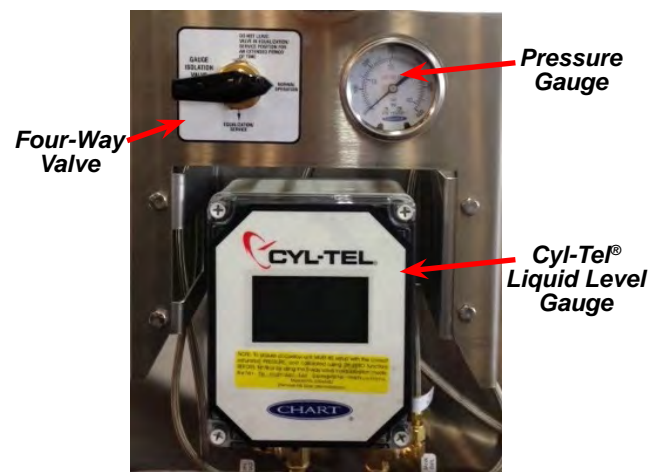

Photo 1

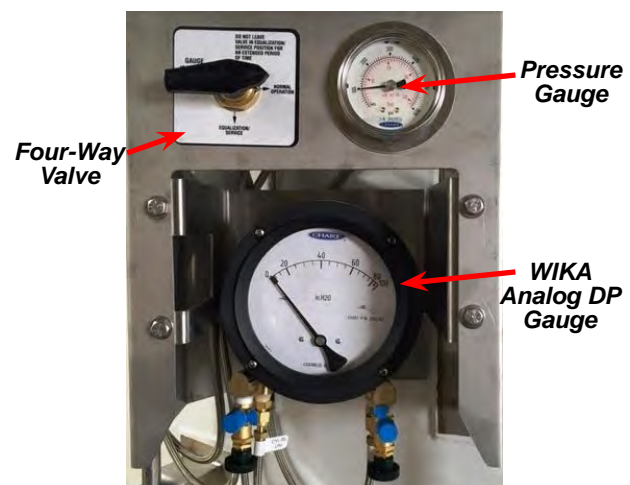

Photo 2

Four-Way Valve

The four-way valve (V-6) is used as the primary isolation valve between the DP gauge and the phase lines from the tank. This four-way valve also provides an easy method to check the zero on the DP gauge. By turning the valve into the equalization position, the DP gauge can be zeroed and isolated from the tank pressure for removal or replacement (see photos 1 & 2).

Pressure Gauge

A single pressure gauge (PI-1) on the Perma-Cyl tank is also tied into the low phase line and gives the operator a pressure reading in the gas phase of the vessel. This pressure gauge can also be isolated with the four-way valve (see photos 1 & 2).

Calibration Chart

Metric Calibration Chart (for 120 psi saturation pressure)									
Perma-Cyl 1500 ZX VHP Cylinder									
H ₂ O	Oxygen			Nitrogen			Argon		
In	Liters	Kg	Cu Ft	Liters	Kg	Cu Ft	Liters	Kg	Cu Ft
0.0	0.0	0.0	0.0	0.0	0.0	0.0	0.0	0.0	0.0
2.0	8.28	8	223	16.87	12	359	5.73	7	150
4.0	31.02	31	836	61.06	43	1299	21.71	27	567
6.0	65.03	66	1,753	122.94	86	2615	46.15	56	1,205
8.0	107.15	108	2,888	192.88	135	4,103	77.26	95	2,018
10.0	154.20	156	4,156	263.75	184	5,610	113.25	139	2,957
12.0	203.05	206	5,473	334.62	234	7,118	152.31	186	3,977
14.0	252.00	255	6,793	405.49	283	8,625	192.67	236	5,031
16.0	300.94	305	8,112	476.37	333	10,133	233.14	285	6,088
18.0	349.89	354	9,431	547.24	383	11,640	273.61	335	7,145
20.0	398.83	404	10,751	618.11	432	13,148	314.08	385	8,202
22.0	447.78	453	12,070	688.98	482	14,655	354.55	434	9,259
24.0	496.72	503	13,389	759.86	531	16,163	395.02	484	10,315
26.0	545.67	552	14,708	830.73	581	17,670	435.49	533	11,372
28.0	594.61	602	16,028	901.60	630	19,178	475.95	583	12,429
30.0	643.56	651	17,347	972.47	680	20,685	516.42	632	13,486
32.0	692.50	701	18,666	1,043.35	729	22,193	556.89	682	14,543
34.0	741.45	751	19,986	1,114.22	779	23,700	597.36	731	15,599
36.0	790.39	800	21,305	1,185.09	828	25,208	637.83	781	16,656
38.0	839.34	850	22,624	1,255.97	878	26,715	678.30	830	17,713
40.0	888.28	899	23,944	1,326.84	928	28,223	718.77	880	18,770
42.0	937.22	949	25,263				759.24	929	19,827
43.6				1,443.71	1,009	30,709			
44.0	986.17	998	26,582				799.71	979	20,883
46.0	1,035.11	1,048	27,902				840.18	1,029	21,940
48.0	1,084.06	1,097	29,221				880.65	1,078	22,997
50.0	1,133.00	1,147	30,540				921.12	1,128	24,054
52.0	1,181.95	1,196	31,859				961.58	1,177	25,111
54.0	1,230.89	1,246	33,179				1,002.05	1,227	26,168
56.0	1,279.84	1,296	34,498				1,042.52	1,276	27,224
58.0	1,328.78	1,345	35,817				1,082.99	1,326	28,281
60.0	1,376.95	1,394	37,116				1,123.46	1,375	29,338
62.0							1,163.93	1,425	30,395
63.1	1,443.71	1,461	38,915						
64.0							1,204.40	1,474	31,452
66.0							1,244.87	1,524	32,508
68.0							1,285.34	1,574	33,565
70.0							1,325.81	1,623	34,622
72.0							1,365.89	1,672	35,669
74.0							1,404.01	1,719	36,664
76.3							1,443.71	1,767	37,701



Note: Volumes of LN₂/LAR/LOX change as the saturation pressure of the liquid in the container changes. For the most accurate contents reading, insure that the table above is converted to the correct saturation pressure.

Troubleshooting

The following table is arranged in a Trouble/Probable Cause/Remedy format. The probable causes for specific problems are listed in descending order of significance. That is, check out the first cause listed before proceeding to the next.

Trouble	Probable Cause	Remedy
No gas to gas-use equipment. OR Insufficient pressure to gas-use equipment	Perma-Cyl tank empty.	<ol style="list-style-type: none"> 1. Switch to emergency gas supply. 2. Call gas supplier for delivery.
	Gas-use valve to final line regulator is closed or other valves downstream are closed.	<ol style="list-style-type: none"> 1. Open valve or valves, as needed. 2. Insure there is no obstruction in the line or valve.
	Pressure builder is not building sufficient pressure.	<ol style="list-style-type: none"> 1. Open pressure building regulator control valve and allow pressure to build. 2. Adjust setting on regulator to a higher pressure. 3. If tank pressure fails to rise, see section on low tank pressure.
	Final line pressure regulator set too low or malfunctioning.	<ol style="list-style-type: none"> 1. Insure gas use valve is open and tank pressure is at least 25 psi higher than desired working pressure of final regulator. 2. Call service technician.
	Inappropriate type of regulator (high-pressure or 2-stage or too small) installed as final line regulator and is not able to supply sufficient gas flow.	<ol style="list-style-type: none"> 1. Insure gas use valve is open and tank pressure is at least 25 psi higher than desired working pressure of final regulator. 2. Inspect final line regulator or its specifications to determine if it has a suitable flow capacity for the required inlet and outlet pressures. 3. Call appropriate equipment supplier or service technician.
	Gas supply line, hose, or network contains excessive pressure drop.	<ol style="list-style-type: none"> 1. Check line for sufficient diameter. 2. Remove all unnecessary bends, elbows, reducers, and small diameter valves. 3. Check for leaks in the gas supply line.
	Unknown	<ol style="list-style-type: none"> 1. Call service technician
Frost or ice on sides, bottom, top-center and / or plumbing of tank.	Normal condition during and following gas use, liquid use or filling.	<ol style="list-style-type: none"> 1. None 2. User to check tank for frost / leaks before use.
	Tank is being used for continuous flow application and is not receiving sufficient ambient heat to melt the frost or ice. (Tank may have heavy ice build-up continuous ice or frost.)	<ol style="list-style-type: none"> 1. Move tank to a warmer location. 2. Add additional environmental heat and / or warm airflow to warm outer piping, components and sides of the tank. 3. Add switchover system to allow tank to rest and warm up when not in use.
	Leak in gas supply lines, gas-use equipment, or tank plumbing. (Frost is present on tank even after an extended period with no gas or liquid use.)	<ol style="list-style-type: none"> 1. Evacuate and ventilate room. 2. If possible, locate and correct leak, 3. User to check tank for frost / leaks each morning before starting gas use. 4. Call appropriate equipment service technician.

Trouble	Probable Cause	Remedy
Frost or ice on sides, bottom, top-center and / or plumbing of tank. (continued)	Weak vacuum or failed vacuum.	<ol style="list-style-type: none"> 1. Check if tank pressure is routinely high even during gas use and / or if tank has cold or ice spots even when not in operation as sign of vacuum problem. 2. Condensation or sweating is seen over the entire outer shell as a sign of vacuum problem. 3. Call gas service agent.
	Unknown.	<ol style="list-style-type: none"> 1. Call gas service agent.
Routinely low pressure in tank.	PB shut-off valve is closed. (If PB is not operating, no frost ring will appear at the bottom of the tank or an external PB vaporizer during gas use.)	<ol style="list-style-type: none"> 1. Open pressure building regulator control valve and allow pressure to build. 2. Call service agent to repair, replace or adjust regulator.
	Pressure builder setting is too low. (If PB is not operating, no frost ring will appear at the bottom of the tank or an external PB vaporizer during gas use.)	<ol style="list-style-type: none"> 1. Adjust regulator to higher pressure and allow pressure to build. 2. Call service agent to repair, replace or adjust regulator.
	Economizer regulator setting is too low or economizer regulator is stuck open.	<ol style="list-style-type: none"> 1. Adjust regulator to higher pressure (should be at least 15 psig above pressure build regulator setting). 2. Check to ensure regulator is not stuck open.
	Relief valve(s) stuck open.	<ol style="list-style-type: none"> 1. Evacuate and ventilate the room. 2. Check exhaust of relief valve to see if gas is flowing at a pressure below the pressure stamped on the valve. 3. Tap lightly on the side of the relief valve to attempt to dislodge any obstruction holding valve open. Repeat several times, if needed. 4. Call gas service technician to replace relief valve, if necessary.
	Large gas leak from tank plumbing or from gas use system.	<ol style="list-style-type: none"> 1. Evacuate and ventilate the room. 2. If possible, locate and repair leak or call gas equipment service technician.
	Gas or liquid withdrawal rate exceeds the tank specifications.	<ol style="list-style-type: none"> 1. Excess usage will cause tank pressure to decrease as PB is unable to maintain pressure. Decrease withdrawal rate to within design specifications. 2. Increase pressure setting on PB regulator. 3. If withdrawing gas, consider: (a) withdrawing liquid and using external vaporizer, (b) installing larger tank, (c) installing additional tank(s), or (d) splitting application. 4. If withdrawing liquid, consider: (a) installing larger tank, (b) splitting application or (c) installing additional tank(s). 5. Call gas service agent.
	Unknown	<ol style="list-style-type: none"> 1. Switch to emergency gas cylinder. 2. Call gas service technician.
Gas supply to gas-use equipment is too cold.	Ambient temperature surrounding the Perma-Cyl tank is too cold.	<ol style="list-style-type: none"> 1. Move tank to warmer location. 2. Install freestanding ambient vaporizer on gas supply line in warmer location or install in-line gas heater.

Trouble	Probable Cause	Remedy
Gas supply to gas-use equipment is too cold. (continued)	Gas withdrawal rate from Perma-Cyl tank exceeds the capacity of tank's ambient vaporizer.	<ol style="list-style-type: none"> 1. Reduce gas withdrawal rate to within specified parameters. 2. Install freestanding ambient vaporizer on gas supply line in warm location or install in-line heated vaporizer on gas supply circuit. 3. Install larger tank with greater withdrawal rate capacity.
Routinely high tank pressure.	Normal when little or no gas has been used for several days.	<ol style="list-style-type: none"> 1. None - Routine use of gas will automatically reduce the tank pressure. 2. Gas usage must exceed NER of tank, if not, contact gas supplier for different tank model.
	Economizer function on regulator is malfunctioning.	<ol style="list-style-type: none"> 1. If tank is in a mixer application and the usage is low, consider drawing gas off the vent line, as the economizer will not work completely in non-consistent draws. 2. Call gas service technician to clean, repair, or replace regulator.
	Tank is over-filled	<ol style="list-style-type: none"> 1. If tank is filled to or beyond proper fill level, pressure builds very rapidly and relief valve may open. 2. Use gas or liquid as soon as possible to reduce tank contents. 3. Vent tank until no liquid is coming out the vent valve.
	Pressure building function on regulator is set too high or regulator is malfunctioning.	<ol style="list-style-type: none"> 1. Reduce pressure setting by turning adjustment knob counter-clockwise to the desired pressure setting and continuing normal gas use until pressure drops. 2. Close PB isolation valve and carefully observe pressure to ensure tank pressure does not drop too low during use. 3. Call gas service technician to adjust PB regulator.
	Weak or failed vacuum.	<ol style="list-style-type: none"> 1. Observe if condensation and / or frost are present even during periods of non-use as possible sign of vacuum problem. 2. Call gas service technician.
	Unknown.	<ol style="list-style-type: none"> 1. Call gas service technician.
Hissing sounds or evidence of gas leaking near tank, gas lines, or gas-use equipment.	Normal for short periods of time from some regulators and relief valves.	<ol style="list-style-type: none"> 1. Evacuate and ventilate room or area, if necessary. 2. If possible, observe leak. If leak is not large, does not last long, does not occur frequently and is in well-ventilated area, no action may be needed. If in doubt, call appropriate equipment service technician. 3. If above combined conditions do not exist, call equipment service technician and observe "Safety" precautions.

Trouble	Probable Cause	Remedy
Hissing sounds or evidence of gas leaking near tank, gas lines, or gas-use equipment. (continued)	Large leaks, leaks from elsewhere in the system, sustained leaks, or frequent leaks (not normal).	<ol style="list-style-type: none"> 1. Evacuate all personnel from affected areas. Ventilate room / area. 2. If possible, locate the leak and repair it or call gas service or gas-use equipment service technician.
High gas usage.	Unrecognized increase in actual gas use.	<ol style="list-style-type: none"> 1. None for Perma-Cyl tank or gas supplier 2. Gas user to determine reason for increase in gas use.
	Leak in gas supply line or network or in gas-use equipment or tank plumbing, e.g. relief valve.	<ol style="list-style-type: none"> 1. Evacuate and ventilate room, if necessary. 2. If possible, locate and repair leak or call gas-use equipment service agent. 3. User to check tank for frost / leaks before operations.
	Tank pressure routinely too high and venting.	<ol style="list-style-type: none"> 1. See troubleshooting section on routinely high tank pressure.
	High flash or vaporization losses in liquid use application due to high pressure / temperature liquid in tank.	<ol style="list-style-type: none"> 1. Vent tank to approximately 25 psi. Follow safety procedures. 2. In future only refill the Perma-Cyl tank with low-pressure cryogenic product.
	Error in gas delivery or supplier invoice.	<ol style="list-style-type: none"> 1. Check gas usage history / pattern against supplier invoices. 2. Call gas supplier, if necessary.
Perma-Cyl tank cannot be filled.	Perma-Cyl tank is full.	<ol style="list-style-type: none"> 1. None
	Fill line is blocked or inoperative.	<ol style="list-style-type: none"> 1. Check for obstructions in the fill line. Clear if necessary. 2. Gently tap on check valve to assure proper operation. 3. Ensure top & bottom fill valves are open. 4. Call gas service technician.
	Orca™ MicroBulk Delivery System is not functioning properly.	<ol style="list-style-type: none"> 1. Refer to Orca system Troubleshooting.
	Transfer hose is obstructed, e.g. hose is bent excessively, crimped or plugged.	<ol style="list-style-type: none"> 1. Clean obstruction, inspect hose for damage, and, if everything is satisfactory, continue the filling.
Perma-Cyl tank does not initiate automatic fill shut off properly.	Fill line piping created too much pressure drop.	<ol style="list-style-type: none"> 1. Ensure fill line is piped with 3/4" nominal copper (or equivalent) with minimal 90° bends. 2. Re-route fill piping.
	Improper fill procedure.	<ol style="list-style-type: none"> 1. Review Orca system/Perma-Cyl tank filling procedure. 2. Ensure that all vent and use valves of the tank are closed.
	Only works with Chart Orca MicroBulk delivery vehicle. For other type trucks use full trycock.	N/A
Liquid withdrawal contains high level of gas.	Saturated liquid pressure in Perma-Cyl tank is too high. (Temperature or energy level of contents is too high due to excess pressure.)	<ol style="list-style-type: none"> 1. Ensure PB shut-off valve is closed. 2. Open vent valve to allow excess pressure to vent until desired pressure is obtained. Follow "Safety" guidelines and procedures for venting. 3. Install secondary lower pressure relief valve to reduce saturated pressure of liquid in the future. 4. In future only refill the Perma-Cyl tank with low-pressure cryogenic product.

<i>Trouble</i>	<i>Probable Cause</i>	<i>Remedy</i>
Vacuum pump-out port and / or vacuum plug are open or damaged.	Pump-out plug or port have been damaged or tampered with.	<ol style="list-style-type: none"> 1. If possible, transfer any remaining contents to another tank. 2. Call gas service technician to replace and repair tank.
	Inner vacuum space leak has dislodged safety pump-out plug.	<ol style="list-style-type: none"> 1. If possible, transfer any remaining contents to another tank. 2. Cover pumpout port to keep moisture from getting into the annular space. 3. Call gas service technician to replace and repair tank.



Warning! *Use only parts which are cleaned and approved for oxygen service. Chart recommends the use of only Chart approved parts.*



Maintenance

Bench Setting a Pressure Building Regulator

1. Connect the pressure building regulator to a nitrogen pressure source as shown in the Figure 2 below.
2. Close Valve B.
3. Open pressure source valve (follow appropriate safety rules).
4. Open Valve C slowly.
5. Pressure Gauge A will indicate the pressure to which the regulator has been set. The pressure can be increased by turning the adjusting screw in or decreased by turning the screw out; however, after each adjustment outward it will be necessary to open and then close Valve B to relieve excess pressure.
6. This procedure may be repeated as many times as necessary to obtain the proper setting.
7. After the proper setting is obtained, secure the lock nut on the adjusting screw.



Note: Factory setting is 450 psig.

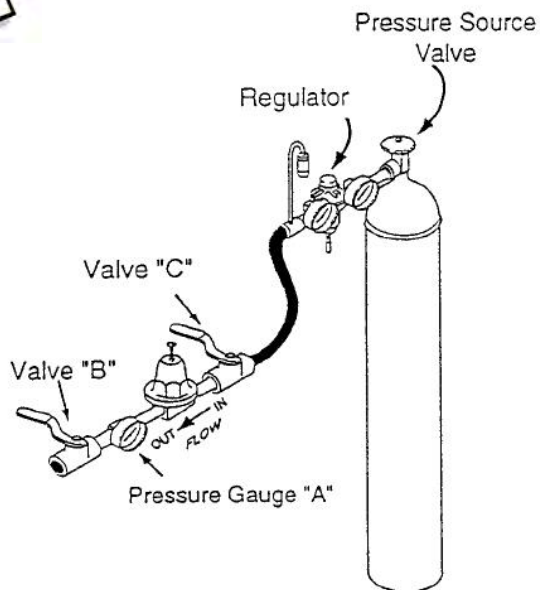

Figure 2 - Pressure Building Regulator

Bench Setting an Economizer Regulator

1. Connect the inlet of the economizer regulator to a pressure source as shown in the Figure 2.
2. Open the valve at the pressure source (follow appropriate safety rules).
3. Slowly open Valve B just enough to allow some gas to escape.
4. Pressure Gauge A will indicate the setting to which the economizer regulator is set. This setting may be increased by turning the adjusting screw in, or lowered by turning the adjusting screw out.
5. Gas will flow through the economizer regulator when the pressure of the gas reaches the pre-set setting.



Note: Factory setting is 475 psig.

Rebuilding the Rego Operational Valves

When a defective valve is suspected, follow this procedure to repair it. Refer to Figure 3 on the next page for identification of parts.

1. Open the valve and release any pressure that is in the container.
2. If the valve to be repaired is the vent valve, allow it to warm up before it is disassembled.
3. If the valve to be repaired is the pressure building valve, the container should be emptied of product and pressure.
4. Remove the valve handle screw (item 3), washer (item 14), retainer cap and spring assembly (items 2, 4, 8, 10 and 13).
5. Remove the valve handle (item 1) and Teflon thrust washer (item 7).
6. Unscrew bonnet (item 5) to remove stem (item 6) and stem seal.
7. Pick out body insert (item 12) and plug assembly (item 9).
8. Clean seat.

9. Replace parts as needed and reassemble in reverse order.

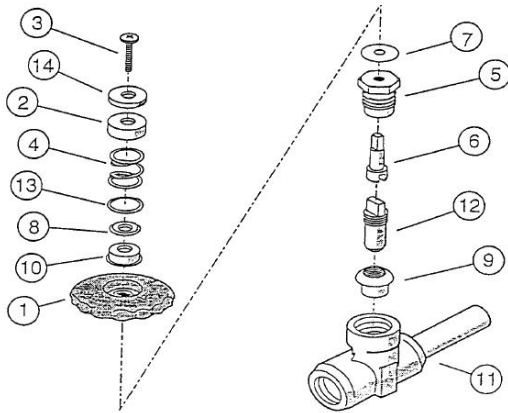

Figure 3 - Globe Valve Components

Item	PN	Qty	Spares*	Description
1	17-1078-9	1	1	Hand wheel
2	17-1086-9	1	1	Spring retainer
3	17-1084-9	1	1	Screw
4	17-1077-9	1	1	Spring
5	17-1081-9	1	1	Bonnet
6	17-1089-9	1	1	Stem
7	17-1088-9	1	1	Gasket
8	17-1087-9	2	2	Washer
9	17-1082-9	1	1	Threaded body insert
10	17-1076-9	1	1	Seal
11	--	--	--	Body assembly
12	17-1083-9	1	1	Seat and nipple assembly
13	17-1080-9	1	1	Washer
14	17-1085-9	1	1	Washer and screw
--	97-1575-9	--	1	Valve repair kit (includes items 1-14, except 11)

*Recommended spare parts

**Parts are also available in complete packages



Specifications

Capacity	
Liquid (Gross) (liters)	1,550
Liquid (Net) (liters)	1,455
Gas (LIN) ft ³ / Nm ³	35,790 / 1,013
Gas (LOX) ft ³ / Nm ³	44,220 / 1,250
Gas (LAR) ft ³ / Nm ³	43,220 / 1,223
Performance	
NER (LIN) % per day	1.0
NER (LAR / LOX) % per day	.62
Gas Flow (LIN / LAR / LOX)* SCFH / Nm ³ / hr**	
Dimensions & Pressure Ratings	
Diameter (cylinder) in / cm	48 / 1,219
Height (cylinder) in / cm	91 / 2,311
Base Width (frame) in / cm	61.5 / 156.21
Base Depth (frame) in / cm	61.5 / 156.21
Base Height (frame) in / cm	93 / 236.22
Tare Weight lb / kg	3,210 / 1,456
Relief Valve Setting psig / barg	450 / 31.0

*At standard pressure and temperature (14.7 psig & 70°F)

**Higher flows can be achieved with reduced duty cycles and/or additional vaporization.

Flow Diagram

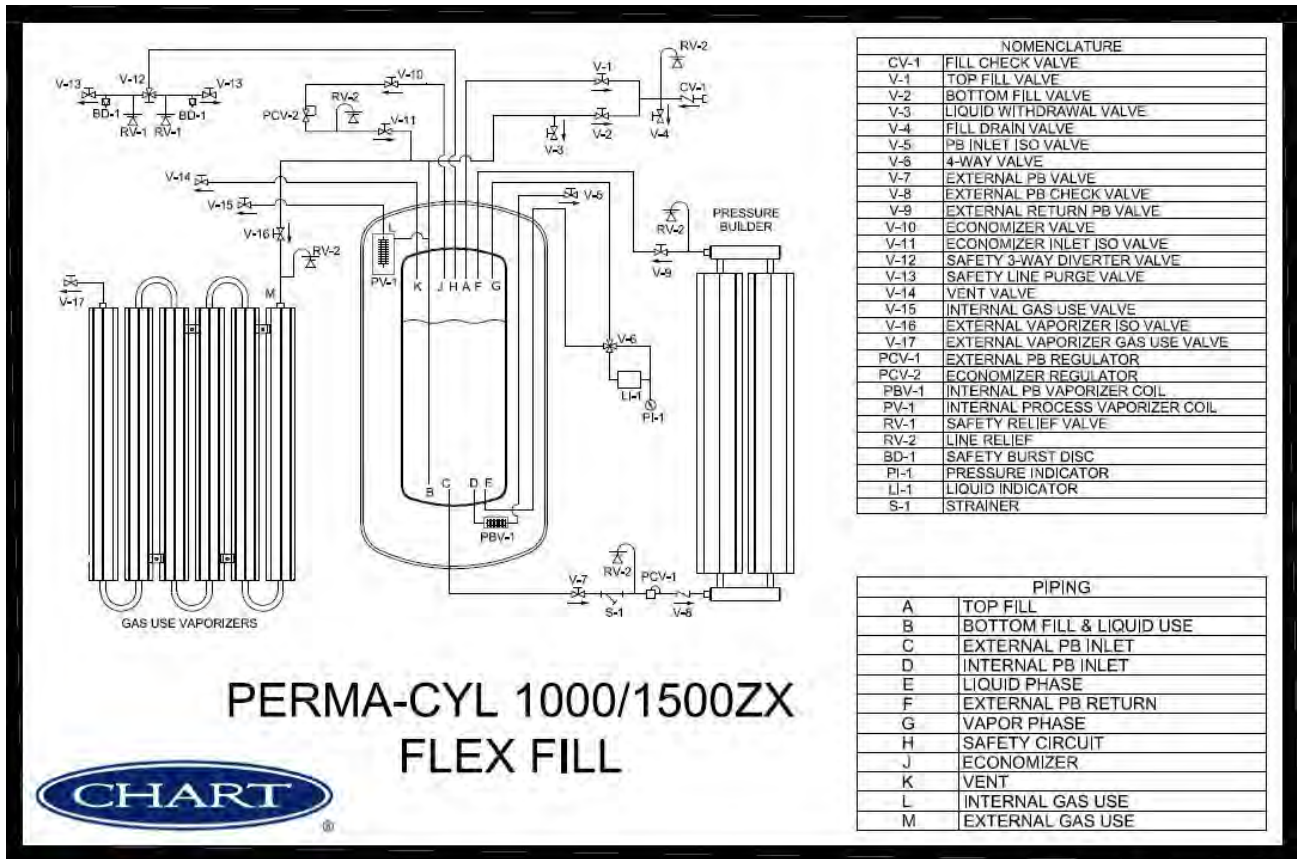

Controls and Function

#	Plumbing Controls & Function	#	Plumbing Controls & Function
CV-1	FILL CHECK VALVE	V-14	VENT VALVE
V-1	TOP FILL VALVE	V-15	INTERNAL GAS USE VALVE
V-2	BOTTOM FILL VALVE	V-16	EXTERNAL VAPORIZER ISO VALVE
V-3	LIQUID WITHDRAWAL VALVE	V-17	EXTERNAL VAPORIZER GAS USE VALVE
V-4	FILL DRAIN VALVE	PCV-1	EXTERNAL PB REGULATOR
V-5	PB INLET ISO VALVE	PCV-2	ECONOMIZER REGULATOR
V-6	4-WAY VALVE	PBV-1	INTERNAL PB VAPORIZER COIL
V-7	EXTERNAL PB VALVE	PV-1	INTERNAL PROCESS VAPORIZER COIL
V-8	EXTERNAL PB CHECK VALVE	RV-1	SAFETY RELIEF VALVE
V-9	EXTERNAL RETURN PB VALVE	RV-2	LINE RELIEF
V-10	ECONOMIZER VALVE	BD-1	SAFETY BURST DISC
V-11	ECONOMIZER INLET ISO VALVE	PI-1	PRESSURE INDICATOR
V-12	SAFETY 3-WAY DIVERTER VALVE	LI-1	LIQUID INDICATOR
V-13	SAFETY LINE PURGE VALVE	S-1	STRAINER

EXT PB Circuit - Top Components

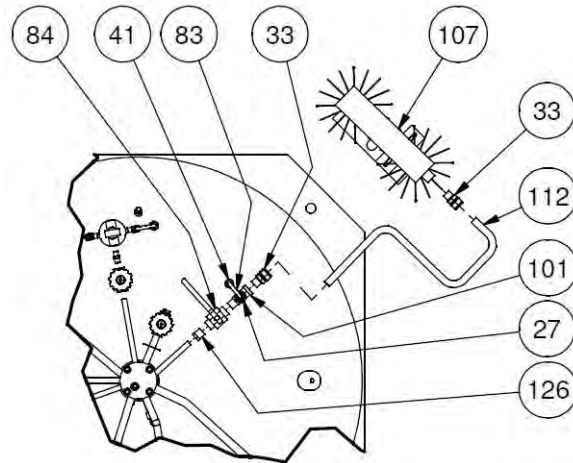

Item	PN	Qty	Description
27	10MC008	1	CONN SS 3/8ODT*1/2MPT
33	10MC005	2	CONN SS 3/4ODT*1/2MPT
41	1812702	1	RV BRS 1/4MPT 550PSI
83	20946824	1	RV TUBE S/A MPV-MAINLINE_3.75 w/FITTINGS
84	1712202	1	VALVE BALL BRS 1/2FPT
101	11551035	1	TEE STREET BRS 1/2NPT FORGED
107	11721436	1	EXT PB 1500ZX TMX FG#FG00242
112	20944978	1	PB_IN TUBE_1500ZX FF_2
126	1212982	1	BSHG HEX BRS 1/2MPT*3/8FPT

EXT Gas Use Components

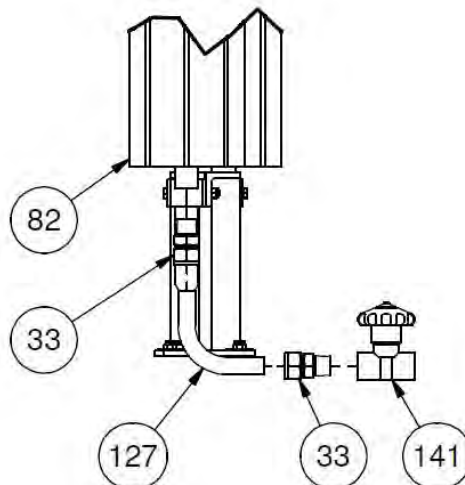

Item	PN	Qty	Description
33	10MC005	2	CONN SS 3/4ODT*1/2MPT
82	14925522	1	VAPORIZER ASSY PERMA-CYL 450ZX
127	13379718	1	TUBE SS .750"OD .049W
141	10502848	1	VALVE SHUTOFF BRZ 1/2FPT SHORT

EXT PB Circuit - Bottom Components

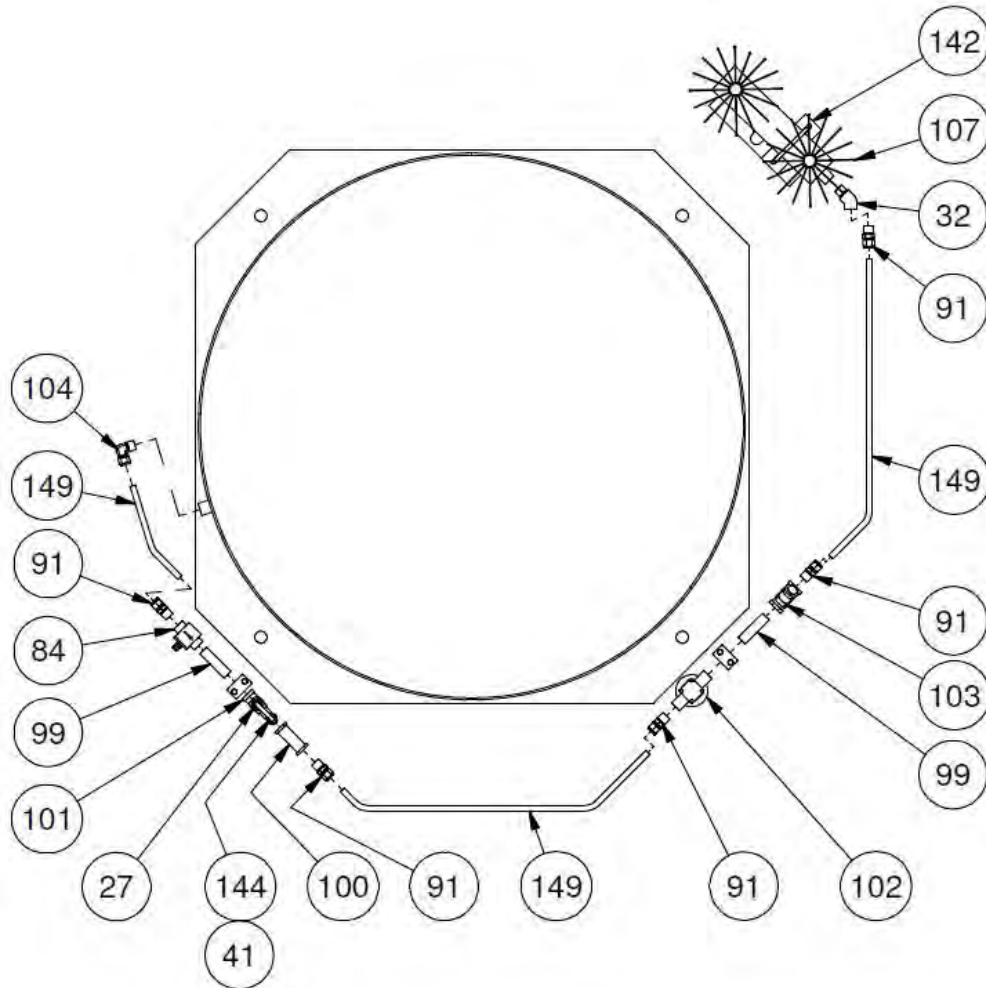

Item	PN	Qty	Description
27	10MC008	1	CONN SS 3/8ODT*1/2MPT
32	1214802	1	ELBOW BRS 45D 1/2FPT*1/2MPT
41	1812702	1	RV BRS 1/4MPT 550PSI
84	1712202	1	VALVE BALL BRS 1/2FPT
91	11357232	5	CONN SS 1/2ODT*1/2MPT
99	1310281	2	NIPPLE SS 1/2NPT*3
100	11529090	1	STRAINER .500NPT BRZ BODY
101	11551035	1	TEE STREET BRS 1/2NPT FORGED
102	11635511	1	REGULATOR .500NPT @ 450PSI
103	13462175	1	KIT CHECK VALVE NIBCO 1/2"FPT
104	11357241	1	ELBOW SS 90D 1/2ODT*1/2MPT
107	11721436	1	EXT PB 1500ZX TMX FG#FG00242
142	11722113	1	VALVE SHUTOFF BRZ 1/2FPT SHORT
144	20894150	1	RV TUBE S/A TRIFECTA-X_15.00 w/o FITTINGS
149	2710201	3	TUBE SS .500"OD .049W WLD

External Vaporizer Components

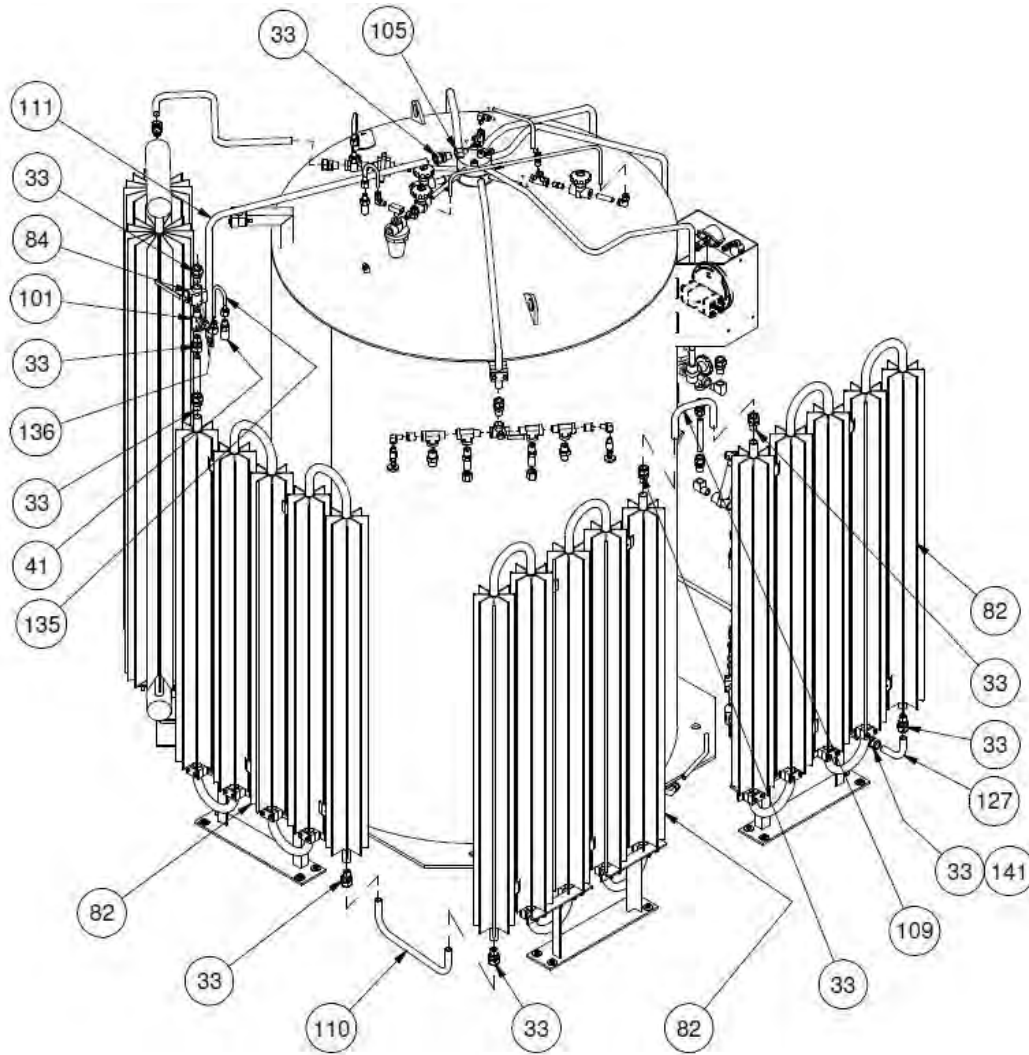

Item	PN	Qty	Description
32	1214802	1	ELBOW BRS 45D 1/2FPT*1/2MPT
33	10MC005	9	CONN SS 3/4ODT*1/2MPT
41	1812702	1	RV BRS 1/4MPT 550PSI
82	14925522	3	VAPORIZER ASSY PERMA-CYL 450ZX
84	1712202	1	VALVE BALL BRS 1/2FPT
101	11551035	1	TEE STREET BRS 1/2NPT FORGED
105	1210852	1	ADAPTER BRS 1/2FPT*1/4MPT
109	20944980	1	UPPER VAPOR TUBE
110	20944981	1	LOWER VAPOR TUBE
111	20944977	1	VAPORIZER-IN TUBE
127	13379718	1	"TUBE SS .750"OD .049W "
135	20894149	1	RV TUBE S/A MPV-MAINLINE_3.75 w/FITTINGS
136	13726821	1	ELBOW BRS 90D 3/8ODT*1/2MPT
141	10502848	1	

Safety Components

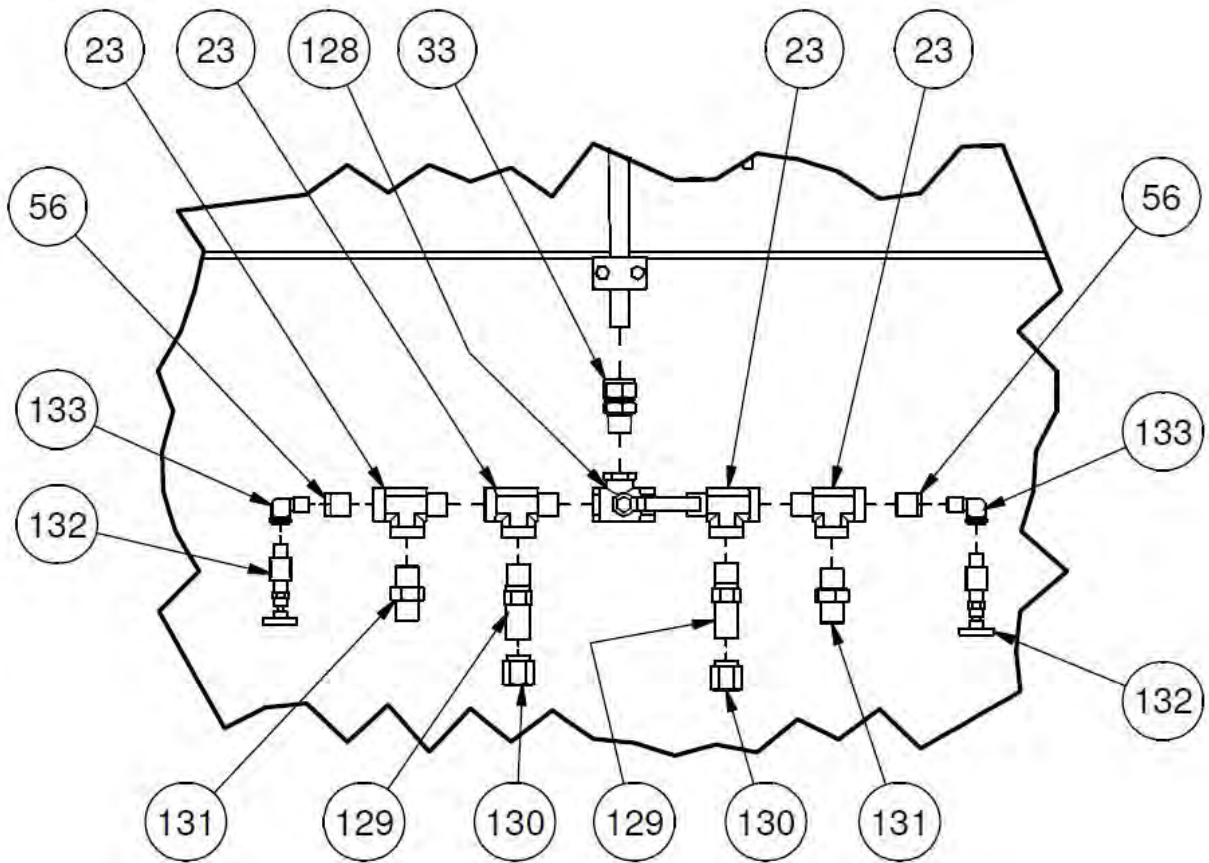

<i>Item</i>	<i>PN</i>	<i>Qty</i>	<i>Description</i>
23	1212082	4	TEE STREET BRS 1/2FPT X 1/2MPT
33	10MC005	1	CONN SS 3/4ODT*1/2MPT
56	1210032	2	BSHG HEX BRS 1/2MPT*1/4FPT
128	11773885	1	VALVE BALL DIV SS 1/2NPT
129	11488591	2	RV BRS 1/2MPT 350PSI ASME SEC VIII
130	1810092	2	RV BRS INLINE ADAPTER 1/2NPT
131	11526622	2	RPD ASSY INLINE 1/2MPT 700PSI ASME
132	10907239	2	VALVE NEEDLE BRS 1/4MPT(ANGLE)
133	1210462	2	ELBOW STREET BRS 90D 1/4MPT

FlexFill™ Piping Option Components

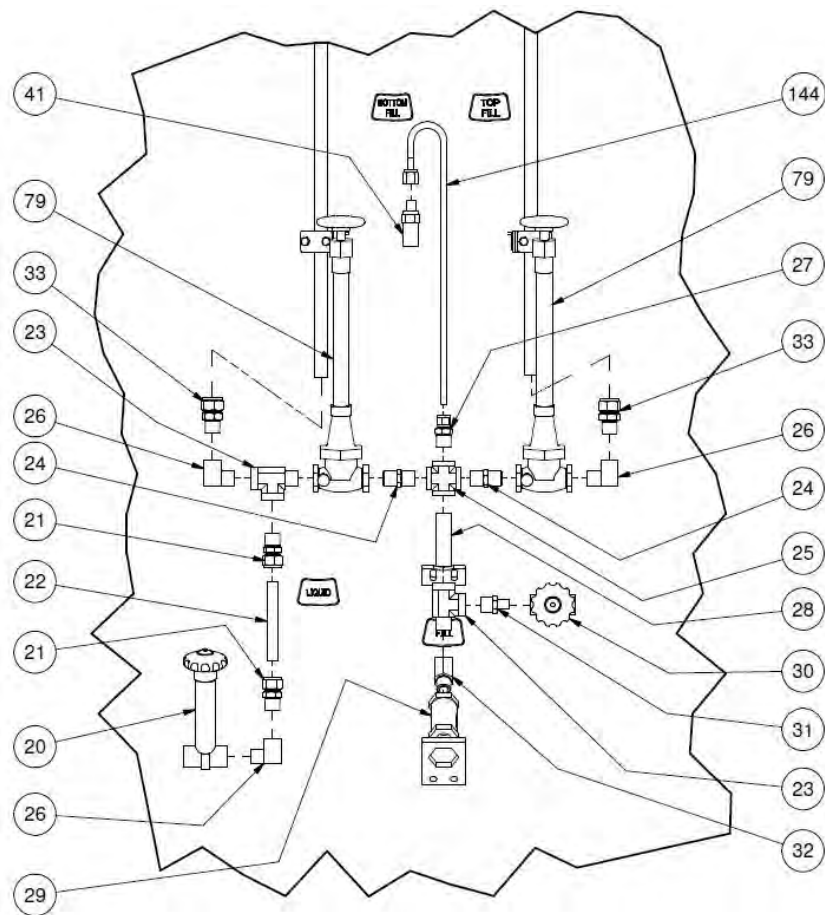

Item	PN	Qty	Description
20	11625639	1	VALVE SHUTOFF 1/2FPT
21	11939558	2	CONN SS 5/8ODT*1/2MPT
22	13698209	1	TUBE SS .625"OD*.049W*4.5"LG
23	1212082	2	TEE STREET BRS 1/2FPT X 1/2MPT
24	1310102	2	NIPPLE HEX BRS 1/2NPT SCH 40
25	11036367	1	CROSS BRS 1/2FPT PARKER # 1/2KMMOO-B
26	11825454	3	ELBOW STREET SS 90D 1/2NPT
27	10MC008	1	CONN SS 3/8ODT*1/2MPT
28	1312502	1	NIPPLE BRS 1/2NPT*3
29	11051090	1	VALVE CHECK BRS 1/2FPT*1/2FPT
30	11905999	1	VALVE SHUTOFF 1/4FPT
31	10599563	1	NIPPLE HEX R BRS 1/2NPT*1/4NPT
32	1214802	1	ELBOW BRS 45D 1/2FPT*1/2MPT
33	10MC005	2	CONN SS 3/4ODT*1/2MPT
41	1812702	1	RV BRS 1/4MPT 550PSI
79	10616790	2	VALVE GLOBE BRS 1/2NPT SCRCD
144	20894150	1	RV TUBE S/A TRIFECTA-X_15.00 w/o FITTINGS

Economizer Components

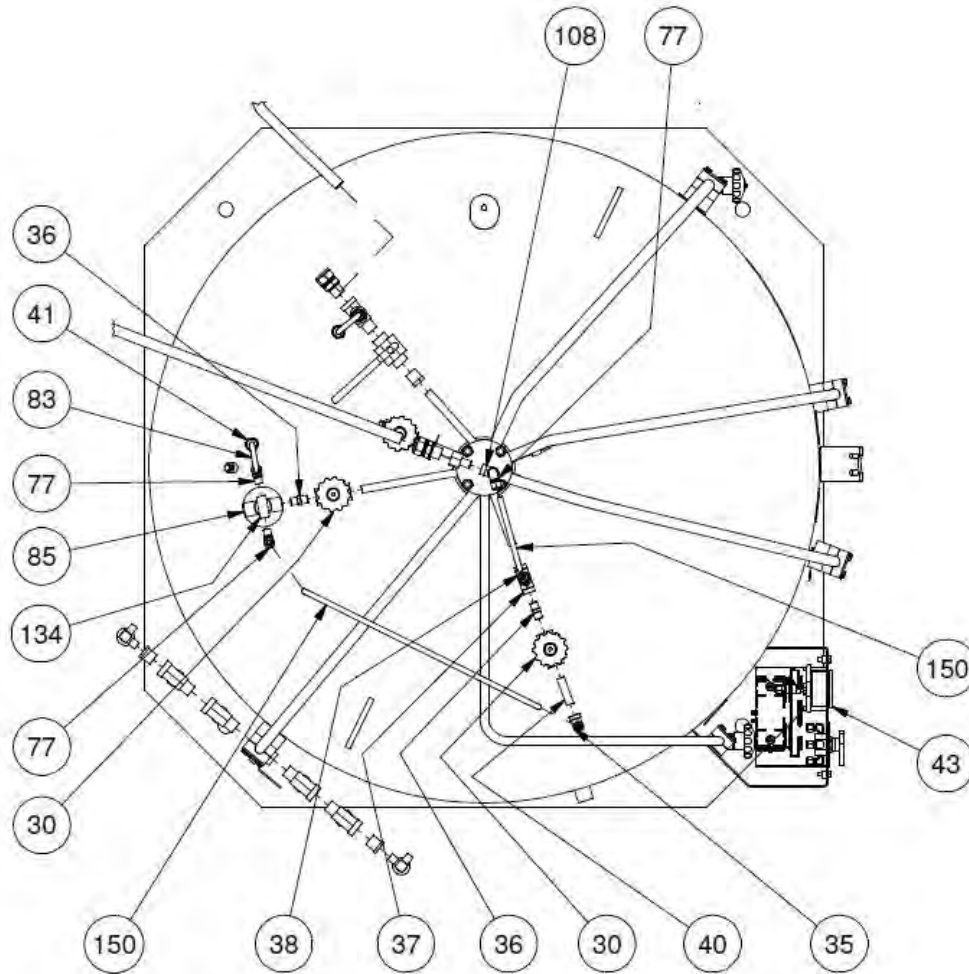

Item	PN	Qty	Description
30	11905999	2	VALVE SHUTOFF 1/4FPT
35	13726476	1	ELBOW BRS 90D 3/8ODT*1/4FPT
36	1310092	2	NIPPLE HEX BRS 1/4NPT SCH 40
37	11499898	1	TEE BRS 3/8FPT
38	13671014	1	CONN BRS 3/8ODT*3/8MPT
40	1310131	1	NIPPLE SS 1/4NPT*2
41	1812702	1	RV BRS 1/4MPT 550PSI
43	13830791	1	KIT PERMA 4-WAY 1000/1500HP
77	11547950	3	ELBOW BRS 90D 3/8ODT*1/4MPT
83	20946824	1	RV TUBE S/A MPV-MAINLINE_3.75 w/FITTINGS
85	20905985	1	REGULATOR .250NPT @ 465PSI
108	14175021	1	TEE STREET BRS 1/4NPT FORGED
134	1213092	1	TEE BRS 1/4FPT*1/4FPT*1/4MPT
150	10591019	2	TUBE CU 0.375"OD LW COIL

Warranty

Chart Packaged Gas Products Warranty Policy

Warranty only applies to original purchaser of Chart equipment and does not transfer to any other party.

Materials, components and workmanship are warranted to be free of defects for 90 days from date of invoice.

Vacuum integrity as measured by conformance to Chart NER (Normal Evaporation Rate) specifications is warranted as follows:

- Perma-Cyl, Mega-Cyl™ or Laser-Cyl™ Liquid Cylinders - 5 years from date of invoice.
- All Chart repaired liquid cylinders - 2 years from date of invoice.

Damage or abuse caused by purchaser voids Chart warranty obligations.

Freight damage incurred during shipment from Chart to purchaser must be reported immediately to Chart, and before placing equipment into service.

In the event of a valid warranty claim, Chart reserves the right to repair, replace or refund the value of the equipment at its discretion. The warranty applies only to the purchased Chart equipment and in no case is Chart obligated to reimburse the purchaser for consequential damages resulting from the operation of Chart equipment.



