



TECHNICAL MANUAL STANDARD ATMOSPHERIC COLD-STRETCHED

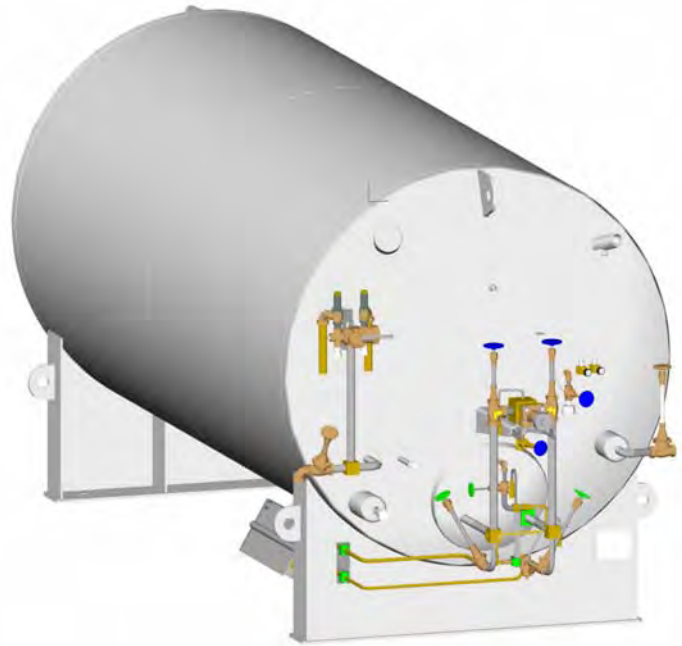

TABLE OF CONTENTS

1	<i>SAFETY</i>	<i>1</i>
1.1	GENERAL	1
1.2	OXYGEN DEFICIENT ATMOSPHERES	1
1.3	OXYGEN ENRICHED ATMOSPHERES	2
1.4	NITROGEN AND ARGON	3
2	<i>VESSEL INFORMATION</i>	<i>5</i>
2.1	RECEIVING CHECKPOINTS	5
2.2	VACUUM CHECK PROCEDURE	5
2.3	PHYSICAL DESCRIPTION	6
2.4	OPERATING DESCRIPTION	7
2.5	PRESSURE BUILD-UP SYSTEM	7
2.6	ECONOMIZER SYSTEM	8
2.7	OPERATOR QUALIFICATIONS	8
3	<i>CONTROLS</i>	<i>9</i>
4	<i>FILLING PROCEDURES</i>	<i>10</i>
4.1	INITIAL FILL	10
5	<i>WITHDRAWAL PROCEDURES</i>	<i>15</i>
5.1	LIQUID DELIVERY	15
5.2	GAS DELIVERY	16
5.3	REGULATOR ADJUSTMENTS	16
6	<i>VESSEL HANDLING INSTRUCTIONS</i>	<i>18</i>
6.1	VESSEL TIE DOWN GUIDELINES	20
7	<i>GENERAL</i>	<i>22</i>

7.1	MAINTENANCE	22
7.1.1	COMPATIBILITY AND CLEANING	22
7.1.2	PERIODIC INSPECTION	22
7.1.3	SOLDERING	22
7.1.4	VACUUM INTEGRITY	23
7.1.5	STORAGE	23
7.2	TROUBLESHOOTING	23
7.3	REPAIR	23
7.4	VALVE REPAIR	24
7.5	REGULATOR REPAIR	26
7.6	GAUGE REPAIRS	27
7.7	INNER TANK BURST DISC REPAIR	27
7.8	TESTING AFTER REPAIR	29
7.9	REGULATOR MAINTENANCE INSTRUCTIONS	30
8	<i>RECOMMENDED SPARES</i>	33
8.1	11001551 RECOMMENDED SPARES 01 1"	33
8.2	11001560 RECOMMENDED SPARES 01 1-1/2"	33
8.3	11060068 RECOMMENDED SPARES DSS 1"	34
8.4	11882379 RECOMMENDED SPARES DSS 1-1/2"	34
8.5	LIQUID LEVEL CHARTS	34
9	<i>DRAWINGS</i>	35

Revision Log	Description
-	Original Issue
A (7/13/11)	Add section 7.1.5 and remove section 7.10.

1 SAFETY

1.1 GENERAL

Cryogenic containers, stationary or portable are from time to time subjected to assorted environmental conditions of an unforeseen nature. This safety bulletin is intended to call attention to the fact that whenever a cryogenic container is involved in any incident whereby the container or its safety devices are damaged, good safety practices must be followed. The same holds true whenever the integrity or function of a container is suspected of abnormal operation.

Good safety practices dictate the contents of a damaged or suspect container be carefully emptied as soon as possible. Under no circumstances should a damaged container be left with product in it for an extended period of time. Further, a damaged or suspect container should not be refilled unless the unit has been repaired and re-certified.

Incidents which require that such practices be followed include: highway accidents, immersion of a container in water, exposure to extreme heat or fire, and exposure to most adverse weather conditions (earthquake, tornadoes, etc.) As a rule of thumb, whenever a container is suspected of abnormal operation, or has sustained actual damage, good safety practices must be followed.

In the event of known or suspected container vacuum problems (even if an extraordinary circumstances such as those noted above has not occurred), do not continue to use the unit. Continued use of a cryogenic container that has a vacuum problem can lead to embrittlement and cracking. Further, the carbon steel jacket could possibly rupture if the unit is exposed to inordinate stress conditions caused by an internal liquid leak.

Prior to reusing a damaged container, the unit must be tested, evaluated, and repaired as necessary. It is highly recommended that any damaged container be returned to Chart for repair and re-certification.

The remainder of this safety bulletin addresses those adverse environments that may be encountered when a cryogenic container has been severely damaged. These are oxygen deficient atmospheres, oxygen enriched atmospheres, and exposure to inert gases.

1.2 OXYGEN DEFICIENT ATMOSPHERES

The normal oxygen content of air is approximately 21%. Depletion of oxygen content in air, either by combustion or by displacement with inert gas, is a potential hazard and users should exercise suitable precautions.

One aspect of this possible hazard is the response of humans when exposed to an atmosphere containing only 8 to 12% oxygen. In this environment, unconsciousness can be immediate with virtually no warning. When the oxygen content of air is reduced to about 15 to 16%, the flame of ordinary combustible materials, including those commonly used as fuel for heat or light, may be extinguished. Somewhat below this concentration, an individual breathing the air is mentally incapable of diagnosing the situation because the onset of symptoms such as sleepiness, fatigue, lassitude, loss of coordination, errors in judgment and confusion can be masked by a state of “euphoria,” leaving the victim with a false sense of security and well being.

Human exposure to atmosphere containing 12% or less oxygen leads to rapid unconsciousness. Unconsciousness can occur so rapidly that the user is rendered essentially helpless. This can occur if the condition is reached by an immediate change of environment, or through the gradual depletion of oxygen.

Most individuals working in or around oxygen deficient atmospheres rely on the “buddy system” for protection-obviously, the “buddy” is equally susceptible to asphyxiation if he or she enters the area to assist the unconscious partner unless equipped with a portable air supply. Best protection is obtainable by equipping all individuals with a portable supply of breathable air. Life lines are acceptable only if the area is essentially free of obstructions and individuals can assist one another without constraint.

If an oxygen deficient atmosphere is suspected or known to exist:

- 1. Use the “buddy system.” Use more than one “buddy” if necessary to move a fellow worker in an emergency.**
- 2. Both the worker and “buddy” should be equipped with self-contained or airline breathing equipment.**

1.3 OXYGEN ENRICHED ATMOSPHERES

An oxygen-enriched atmosphere occurs whenever the normal oxygen content of air is allowed to rise above 23%. While oxygen is nonflammable, ignition of combustible materials can occur more readily in an oxygen-rich atmosphere than in air; and combustion proceeds at a faster rate although no more heat is released.

It is important to locate an oxygen system in a well ventilated location since oxygen-rich atmospheres may collect temporarily in confined areas during the functioning of a safety relief device or leakage from the system.

Oxygen system components, including but not limited to, containers, valves, valve seats, lubricants, fittings, gaskets and interconnecting equipment including hoses, shall have adequate compatibility with oxygen under the conditions of temperature and pressure to which the components may be exposed in the containment and use of oxygen. Easily ignitable materials shall be avoided unless they are parts of equipment or systems that are approved, listed, or proved suitable by tests or by past experience.

Compatibility involves both combustibility and ease of ignition. Materials that burn in air may burn violently in pure oxygen at normal pressure, and explosively in pressurized oxygen. In addition, many materials that do not burn in air may do so in pure oxygen, particularly when under pressure. Metals for containers and piping must be carefully selected, depending on service conditions. The various steels are acceptable for many applications, but some service conditions may call for other materials (usually copper or its alloy) because of their greater resistance to ignition and lower rate of combustion.

Similarly, materials that can be ignited in air have lower ignition energies in oxygen. Many such materials may be ignited by friction at a valve seat or stem packing, or by adiabatic compression produced when oxygen at high pressure is rapidly introduced into a system initially at low pressure.

1.4 NITROGEN AND ARGON

Nitrogen and argon (inert gases) are simple asphyxiates. Neither gas will support or sustain life and can produce immediate hazardous conditions through the displacement of oxygen. Under high pressure these gases may produce narcosis even though an adequate oxygen supply sufficient for life is present.

Nitrogen and argon vapors in air dilute the concentration of oxygen necessary to support or sustain life. Inhalation of high concentrations of these gases can cause anoxia, resulting in dizziness, nausea, vomiting, or unconsciousness and possibly death. Individuals should be prohibited from entering areas where the oxygen content is below 19% unless equipped with a self-contained breathing apparatus. Unconsciousness and death may occur with virtually no warning if the oxygen concentration is below approximately 8%. Contact with cold nitrogen or argon gas or liquid can cause cryogenic (extreme low temperature) burns and freeze body tissue.

Persons suffering from lack of oxygen should be immediately moved to areas with normal atmospheres. **SELF-CONTAINED BREATHING APPARATUS MAY BE REQUIRED TO PREVENT ASPHYXIATION OF RESCUE WORKERS.** Assisted respiration and supplemental oxygen should be given if the victim is not breathing. If cryogenic liquid or cold boil-off gas contacts worker's skin or eyes, the affected tissue should be flooded or soaked with tepid water (105-115°F or 41-46°C). **DO NOT USE HOT WATER.** Cryogenic burns that result in blistering or deeper tissue freezing should be examined promptly by a physician.

Additional information on nitrogen and argon and liquid cylinders is available in CGA Pamphlet p-9. Write to the Compressed Gas Association, Inc., New York, NY 10110.

NOTE :

Extracted from Safety Bulletin SB-2 from Compressed Gas Association, Inc., New York, dated March 1966 and from the "Nitrogen Material Safety Data Sheet" published by Air Products and Chemicals, Inc., Allentown, PA 18105, dated 1 June 1978.

2 VESSEL INFORMATION

Although vessels may vary in piping and plumbing details, some general comments on configuration and operation can be made.

2.1 RECEIVING CHECKPOINTS

1. Check braces, skids, wooden chocks, and other shipping supports. Damage or deformation would indicate the possibility of mishandling during shipment.
2. Examine welded or brazed joints on plumbing for cracks or deformation, especially near valves and fittings.
3. Check points where pipes exit the tank for cracks or breaks.
4. Check relief valves and burst discs for dirt or damage.
5. Check pressure within vessel on PI-1. If pressure is zero, extra precautions against contamination and impurities must be taken.
6. Examine the 5g impactograph. If it has sprung, damage may have occurred during shipment. Notify your company's tank specialist and/or CHART.
7. Check the container vacuum.
 - a) If warm vacuum for "NC" models is above 20 microns, consult factory.

2.2 VACUUM CHECK PROCEDURE

CAUTION: UNAUTHORIZED CHANGING OF THE VACUUM PROBE WILL VOID VESSEL WARRANTY.

1. The standard CHART vacuum probe is a Teledyne-Hastings DV-6R probe. Select a compatible instrument to read the output of the vacuum probe.
2. Remove the rubber cap on probe outlet to expose contact. Note that probe housing need not be opened to do this.
3. Plug the instrument to the probe and calibrate the instrument.

4. Open the vacuum probe isolation valve. Wait for 5 minutes and take vacuum reading. Note that valve handle protrudes through protective housing and can be turned without opening the housing.
5. Close the isolation valve and take a second reading. Monitor the rate of rise in vacuum probe with isolation valve closed. If the vacuum continues to rise at a constant rate, it is possible that the probe assembly is leaking. Consult the factory.
6. Verify that the isolation valve is closed.
7. Replace the rubber probe cap.

Compare the vacuum reading obtained now to reading taken prior to shipping.

2.3 PHYSICAL DESCRIPTION

A Chart vessel is designed for long-term storage of cryogenic liquefied gases under pressure in the range of 5 PSI (0.4 kg/cm²) to the MAWP (Maximum Allowable Working Pressure). Operation of the station can be fully automatic with the unit's regulator system set to maintain preset pressure and flow conditions into a customer's pipeline. While hardware may vary slightly from model to model, each unit essentially performs the same functions.

The vessel is comprised of an alloy steel inner tank encased in an outer carbon steel vacuum shell. The insulation system between the inner and outer containers consists of composite insulation and high vacuum to ensure long holding time. The insulation system designed for long-term vacuum retention is permanently sealed at the factory to ensure vacuum integrity. The units have a tank pressure relief device, which is set at the factory. As a secondary pressure relief device, the container is further protected from over-pressurization by a rupture disc. The bursting disc will rupture completely to relieve inner tank pressure in the event the tank relief valve fails and pressure exceeds the rupture disc setting. The vacuum space is protected from over-pressurization by use of a tank annulus rupture disc assembly. Pressure relief devices used on Chart vessels designed for the U.S. specifications meet the requirements of CGA Pamphlet S1.3, "Pressure Relief Device Standards, Part 1, for Stationary Vessels."

The stations are leg mounted. Lifting lugs are secured to the bottom head and to the top head of the container. The lifting lugs are provided to facilitate handling. Moving requires the use of a crane and adherence to specific rigging instructions, which may vary from vessel to vessel. Some Chart vessels cannot be lifted with one hook only.

Controls Used To Operate The System Are Mounted Under And On The Sides Of The Customer Station. The Pressure Gauge And Liquid Level Gauge Are Located At Eye Level On The Container For Ease Of Viewing.

Single Regulator System

Single regulator system has a single regulator, which doubles as an economizer regulator and a pressure building regulator. The regulator in the economizer circuit automatically allows vapor space gas to be introduced preferentially into the final line or gas use circuit when the customer station pressure exceeds the regulator setting. The pressure building circuit is responsible for maintaining a minimum set pressure in the vessel.

Dual Regulator System

Dual regulator system has two regulators, which has an economizer regulator and a pressure building regulator. The regulator in the economizer circuit automatically allows vapor space gas to be introduced preferentially into the final line or gas use circuit when the customer station pressure exceeds the regulator setting. The pressure building circuit is responsible for maintaining a minimum set pressure in the vessel.

The normal operating pressure range of a vessel is from 60 PSI to approximately 175 PSI. Operating pressure can be increased or decreased as desired by adjusting the regulator, for vessels requiring a different range the PB/Econo regulator spring may be changed.

2.4 OPERATING DESCRIPTION

Vessel operation is governed by the pressure build-up system and the economizer system. The pressure build-up system and the economizer system may be combined into a single regulator system for more effective low withdrawal operations.

2.5 PRESSURE BUILD-UP SYSTEM

The pressure build-up system consists of an ambient air vaporizer and pressure building regulator. When tank pressure becomes lower than the set point of the pressure building regulator, the regulator will open. As a result, liquid will be able to flow through the vapor trap in the annulus, through the isolation valve and regulator to be expanded to vapor in the pressure building coil. The vapor accumulates in the inner tank vapor space to increase pressure. This flow continues until inner tank pressure is equal to regulator setting. When the pressures are equal, the regulator closes. This system thus automatically maintains station pressure as required.

**** NOTE: Upon tank installation. The nuts mounting the PB coil (PBC-1) to the respective brackets must be loosened $\frac{1}{2}$ - $\frac{3}{4}$ turns to allow for expansion & contraction.**

2.6 ECONOMIZER SYSTEM

The economizer system allows the excess gas, which accumulates in the vapor space during periods of low or no use to be consumed preferentially, in effect, it acts like an adjustable in-line relief valve, venting the tank into the customer use line. When vessel pressure is high, above the set point of the regulator, it opens. This allows gas, which flows more easily than the liquid, to flow out of the vapor space, through the isolation valve, regulator, and finally back into the tank to connect to the gas use line. This preferential flow continues until the regulator closes. The single regulator is designed to automatically set the economizer circuit to regulate at 7 PSI (0.5 kg/cm²) higher than that of the pressure building circuit. On dual regulator systems the preset economizer regulator is set at 20PSI (1.4kg/cm²).

2.7 OPERATOR QUALIFICATIONS

Chart Stations are designed for safe and simple operation. The operator is expected to be knowledgeable of the nature of the gas(es) with which he is working, as well as all applicable safety requirements. This manual contains several chapters dealing with Operating instructions, Handling Instructions, and Maintenance Procedures. To fully understand these procedures, we recommend the operator first become familiar with controls and indicators.

3 CONTROLS

Chart cryogenic container operating procedures specify that the operator shall be familiar with all controls and indicators as well as safety considerations. The following controls and indicators should be located and identified on the vessel prior to filling or putting the vessel into operation.

For a list of controls and indicators, see Process & Instrument Diagram in Section 8.

4 FILLING PROCEDURES

This chapter provides the initial fill, gas use, liquid delivery, and refilling procedures for the vessel described in this manual. Before performing any of the procedures contained in this chapter, become familiar with the location and function of the controls and indicators.

4.1 INITIAL FILL

The initial fill is usually performed on a warm vessel, one that has not been in use for an extended period. The warm container must be purged to ensure product purity.

When preparing the tank for filling or when changing service, the following items should be considered:

1. The vessel should be inspected for possible damage or unsuitability for intended use. If damage is detected (e.g. serious dents, loose fittings, etc.) remove the unit from service and perform repairs as soon as possible.
2. The vessel may be filled by pumping or pressure transfer. If vessel pressure is at least 50 PSI (3.5 kg/cm²) less than the maximum allowable pressure of the supply unit, liquid may be transferred by pressure transfer. If the normal working pressure of the station is equal to or greater than the maximum allowable pressure of the supply unit, liquid must be pumped into the tank.
3. To remove the moisture or foreign matter from the tank or tank lines, the vessel must be purged. Use a small amount of new product for purging when changing service and a small amount of the same product if the purge is to ensure purity or remove contaminants.
4. When changing service, the approved CGA (or other keyed) fitting will have to be installed for connection FC-1.

Table 1 Vessel Purging Procedure

STEP NUMBER	Purging Procedure
	CAUTION
	<p>The maximum purge pressure should be equal to 50 percent of the maximum operating pressure of the tank or 30 PSI (2.1 kg/cm²), whichever is less. The maximum purge pressure should be determined before starting the purge operation. To prevent drawing atmospheric contaminants back into the tank, a positive pressure of at least 5 PSI (0.4 kg/cm²) must always be maintained in the tank.</p> <p>Attach the source of liquid purge to the fill connection (FC-1).</p>
1	<p>Close all valves except the pressure build-up valves (HCV-3, HCV-11) and liquid level gauge vapor phase and liquid phase shutoff valves (HCV-8, HCV-10).</p>
	NOTE
2	<p>The pressure building/economizer regulator or pressure building regulator in the dual regulator system (PCV-1) is <i>normally</i> set to build pressure to 120 PSI. When this pressure is used as the purge pressure, DO NOT adjust the regulator adjusting screw. When a solenoid valve is used to control the pressure building circuit, it must be energized.</p> <p>Open hose drain valve (HCV-7), and allow source to vent through hose. Vent until slight frosting appears on hose. Close hose drain valve (HCV-7).</p>
3	<p>Open the bottom fill valve (HCV-1) enough to allow liquid to flow slowly into the tank through the bottom fill line. The gradual flow enables the liquid to vaporize in the line and pressure buildup coil and slowly build up pressure in the inner tank.</p>
4	<p>Shut off the liquid supply source when the pressure in the tank reaches the maximum purge pressure as indicated on tank pressure gauge (PI-1).</p>
5	<p>Open the fill line drain valve (HCV-7) slowly to avoid splashing of the liquid. Drain all liquid from the tank. The appearance of gas (vapor) at the drain indicates that all liquid has been drained.</p>
6	<p>Close drain valve (HCV-7) and bottom fill valve (HCV-1).</p>
7	<p>Open the liquid level gauge equalization valve (HCV-9) to prevent damage to the gauge before closing the liquid level gauge vapor phase and liquid phase shut-off valves. When all liquid is drained, close the liquid level gauge vapor phase and liquid phase shut-off valves (HCV-8, HCV-10).</p>
8	<p>Loosen the unions on either side of the liquid level gauge (LI-1). Both the upper and lower liquid level gauge valves (HCV-8, HCV-10) should be opened wide and the gas streams visually checked for signs of moisture. Provided no moisture is observed after blowing the lines for approximately two minutes, both valves should be closed. If moisture is observed in the gas stream, the gas should be discharged until it is clear of all moisture.</p>

STEP NUMBER	Purging Procedure	
9	<p style="text-align: center;">NOTE</p> <p>A careful check for moisture in the phase lines will ensure trouble free operation of the liquid level gauge. Due to their small diameter, gauge lines are easily plugged by ice.</p>	
10	<p>Open the vapor vent valve (HCV-12) and full trycock valve (HCV-4). The top fill valve (HCV-2) will have to be vented by opening hose drain valve (HCV-7).</p>	
11	<p>Repeat purge procedure 2 through 6 and 10 at least three times to ensure product purity.</p>	
12	<p>Reconnect the liquid level gauge (LI-1), open the liquid level control valves (HCV-8, HCV-10), then close the by-pass valve (HCV-9).</p>	
13	<p>After purging the tank, but before filling, verify that the following valves are open or closed as indicated.</p>	
	<p>Valve</p> <p>Bottom fill valve HCV-1</p> <p>Top fill valve HCV-2</p> <p>Vapor vent valve HCV-12</p> <p>Full trycock valve HCV-4</p> <p>Liquid level gauge equalizing valve HCV-9</p> <p>Product supply valve HCV-13</p> <p>Pressure building inlet/outlet valves HCV-3/HCV-11</p> <p>Economizer isolation valve HCV-17</p> <p>Liquid level gauge liquid phase valve HCV-10</p> <p>Liquid level gauge vapor phase valve HCV-8</p>	<p>Position</p> <p>Closed</p> <p>Closed</p> <p>Closed</p> <p>Closed</p> <p>Closed</p> <p>Closed</p> <p>Closed</p> <p>Closed</p> <p>Open</p> <p>Open</p>

Table 2 Initial (Warm Tank) Filling Procedure

STEP NUMBER	Initial (Warm Tank) Filling Procedure
1	Purge tank to assure product purity
2	Verify that the contents of the supply unit is the proper product to be transferred.
3	Verify that all valves except liquid phase-high (HCV-10) and gas phase-low (HCV-8) are closed.
4	Connect the supply unit transfer hose to tank fill connection (FC-1).
	NOTE
	Cool down the transfer hose prior to filling by opening hose drain valve (HCV-7) and venting the supply unit through the hose for approximately three minutes. Close drain valve (HCV-7).
5	Open bottom fill valve (HCV-1) slowly. If a pressure transfer is to be made, allow pressure to build up in the liquid supply unit until it is at least 50 PSI (3.5 kg/cm ²) higher than station pressure. Open the discharge valve on the supply unit to begin flow.
	(or)
	If a pump transfer is to be made, make the required connections to the pump. Open the supply unit transport discharge valve slowly. Maintain pump discharge pressure from 50 PSI (3.5 kg/cm ²) to 100 PSI (7.0 kg/cm ²) higher than the tank pressure. Fill slowly.
6	Monitor pressure in tank during filling. If pressure rises above supply pressure, or near relief valve pressure, the tank may have to be vented through the vapor vent valve (HCV-12), should pressure continue to rise, the fill may have to be interrupted to allow pressure to drop.
7	Monitor liquid level contents gauge (LI-1). When the gauge indicates approximately three-quarters full, open full trycock valve (HCV-4)
8	When liquid spurts from full trycock valve (HCV-4), immediately stop fill at the supply source and close full trycock valve (HCV-4).
9	Close bottom fill valve (HCV-1).
10	Drain residual liquid in the fill hose via drain valve (HCV-7).
11	Relieve fill hose pressure by loosening the hose at fill connection, then disconnect the hose. It is recommended that the fill hose be allowed to defrost to prevent moisture from being drawn inside the hose.

Table 3 Vessel Refilling Procedure

STEP NUMBER	Vessel Refilling Procedure
1	<p style="text-align: center;">NOTE</p> <p>Filling a cryogenic vessel through the bottom tends to raise pressure in the vessel as gases in vapor space are compressed. Filling through the top tends to lower pressure as gases in head space are cooled down and re-liquefied.</p>
2	Verify that the contents of the supply unit is the proper product to be transferred.
3	Verify that the bottom and top fill valves are closed (HCV-1, HCV-2).
4	Verify minimum required operating pressure in vessel.
5	Verify that all other valves are in normal operating positions.
6	Connect the supply unit transfer hose to tank fill connection (FC-1).
7	<p style="text-align: center;">NOTE</p> <p>Cool and purge down the transfer hoses prior to filling by opening hose drain valve (HCV-7) and the supply unit discharge valve for approximately three minutes or until hose begins to frost. Close drain valve (HCV-7).</p>
8	Open top fill valve (HCV-2) completely.
	<p>If a PRESSURE TRANSFER is to be made, allow pressure to build up in the liquid supply unit until it is at least 50 PSI (3.5Kg/cm²) higher than station pressure. Open the discharge valve on the supply unit to begin flow.</p> <p style="text-align: center;">(or)</p>
	<p>If a PUMP TRANSFER is to be made, make the required connections to the pump. Open the supply unit transport discharge valve slowly. Close pump circulating valve slowly, so as not to lose pump prime. Maintain pump discharge pressure from 50 PSI (3.5 kg/cm²) to 100 PSI (7.0 kg/cm²) higher than tank pressure.</p>
9	Monitor pressure in vessel as indicated. If pressure begins to drop to near the minimum operating pressure, begin to open bottom fill valve (HCV-1), and throttle top fill valve (HCV-2), until pressure stabilizes.
10	Monitor liquid level contents gauge (LI-1). When the gauge indicates approximately three-quarters full, open full trycock valve (HCV-4).
11	When liquid spurts from full trycock valve (HCV-4), stop fill at the supply source and close full trycock valve (HCV-4).
12	Close tank fill valves (HCV-1, HCV-2).
13	Drain residual liquid in the fill hose via drain valve (HCV-7).
14	Relieve fill hose pressure by loosening the hose at the fill connection, and then disconnect the hose

5 WITHDRAWAL PROCEDURES

This chapter provides general guidelines for product decanting in either gaseous or liquid form for the vessel described in this manual. Before performing any of the procedures contained in this chapter, become familiar with the location and function of the controls and indicators.

NOTE

When using a vessel for gaseous service, a free standing vaporizer will have to be installed between the Gas Use connection and a final line pressure regulating system.

5.1 LIQUID DELIVERY

Table 4 Liquid Withdrawal Procedure

STEP NUMBER	Liquid Withdrawal Procedure
1	Connect customer line liquid withdrawal connection (C-1).
2	Verify that all valves except gauge liquid phase valve (HCV-10) and the gauge gas phase valve (HCV-8) are closed.
3	Observe pressure building regulator/economizer regulator or pressure building regulator in the dual regulator system (PCV-1) setting as indicated on the station pressure gauge (PI-1). If station pressure is too high, open vent valve (HCV-12) to relieve excessive gas. It is possible that regulator springs will require changing for lower operational pressure.
4	Open liquid withdrawal valve (HCV-18) slowly to begin liquid flow.
5	Once the desired amount of liquid has been delivered, close the liquid withdrawal valve (HCV-18).

5.2 GAS DELIVERY

Table 5 Gas Withdrawal Procedure

STEP NUMBER	Gas Withdrawal Procedure																						
1	Connect customer line to vessel gas use connection (VAP) or to the optional final line connection if used.																						
2	Verify that all valves except gauge liquid phase (HCV-10) and gauge gas phase (HCV-8) are closed.																						
3	Open product supply valve (HCV-13), pressure building inlet valve (HCV-3), PB outlet valve (HCV-11), and economizer shut-off valve (HCV-17) to start gas flow. At this time, final line pressure gauge will be indicating pressure in the customer line and the system will automatically deliver gas until stopped, or vessel is empty.																						
4	<p>The liquid regulator will not open until the set pressure is reached, thus preferentially drawing vapor off the head space.</p> <p>Once the required amount of product has been delivered (or to close the tank down for an extended period of time), stop gas flow by closing gas use valve (HCV-13). The operation of a Chart unit is completely automatic, valves need to be opened and closed only during filling and during major maintenance.</p>																						
5	<p>Normal operating valve position for a VS unit are as follows:</p> <table border="0" data-bbox="402 961 998 1228"> <tr> <td>Bottom fill valve HCV-1</td> <td>Closed</td> </tr> <tr> <td>Top fill valve HCV-2</td> <td>Closed</td> </tr> <tr> <td>Vapor vent valve HCV-12</td> <td>Closed</td> </tr> <tr> <td>Full trycock valve HCV-4</td> <td>Closed</td> </tr> <tr> <td>Liquid level gauge equalizing valve HCV-9</td> <td>Closed</td> </tr> <tr> <td>Hose drain valve HCV-7</td> <td>Closed</td> </tr> <tr> <td>Product supply valve HCV-13</td> <td>Open</td> </tr> <tr> <td>Pressure building inlet/outlet valves HCV-3/HCV-11</td> <td>Open</td> </tr> <tr> <td>Economizer isolation valve HCV-17</td> <td>Open</td> </tr> <tr> <td>Liquid level gauge liquid phase valve HCV-10</td> <td>Open</td> </tr> <tr> <td>Liquid level gauge vapor phase valve HCV-8</td> <td>Open</td> </tr> </table>	Bottom fill valve HCV-1	Closed	Top fill valve HCV-2	Closed	Vapor vent valve HCV-12	Closed	Full trycock valve HCV-4	Closed	Liquid level gauge equalizing valve HCV-9	Closed	Hose drain valve HCV-7	Closed	Product supply valve HCV-13	Open	Pressure building inlet/outlet valves HCV-3/HCV-11	Open	Economizer isolation valve HCV-17	Open	Liquid level gauge liquid phase valve HCV-10	Open	Liquid level gauge vapor phase valve HCV-8	Open
Bottom fill valve HCV-1	Closed																						
Top fill valve HCV-2	Closed																						
Vapor vent valve HCV-12	Closed																						
Full trycock valve HCV-4	Closed																						
Liquid level gauge equalizing valve HCV-9	Closed																						
Hose drain valve HCV-7	Closed																						
Product supply valve HCV-13	Open																						
Pressure building inlet/outlet valves HCV-3/HCV-11	Open																						
Economizer isolation valve HCV-17	Open																						
Liquid level gauge liquid phase valve HCV-10	Open																						
Liquid level gauge vapor phase valve HCV-8	Open																						

5.3 REGULATOR ADJUSTMENTS

NOTE :

To field set or adjust regulators quickly the vessel must preferably be a full tank.

Under normal circumstances, the system does not require adjustment. However, it may be necessary to change regulator settings to obtain either higher or lower pressure setting within the range of the factory installed springs, at the time of starting up a vessel. It is good practice to verify set points during an initial fill.

The adjustments which follows are required to “final set” the regulator following spring replacement, or after completing valve repairs which required disassembly and reassembly.

Single Regulator System

The economizer regulator circuit will automatically be set 7 PSI (0.5 kg/cm²) higher than pressure building regulator. The pressure building regulator should be set approximately 20 PSI to 40 PSI higher than the desired delivery pressure. Detailed regulator adjustment procedures are provided in tables.

Dual Regulator System

The economizer regulator is normally set 20 PSI (1.4 kg/cm²) higher than pressure building regulator. The pressure building regulator should be set approximately 20 PSI (1.4 kg/cm²) to 40 (2.8 kg/cm²) PSI higher than the desired delivery pressure. Detailed regulator adjustment procedures are provided in tables.

Table 6 Pressure Building Regulator Adjustment

STEP NUMBER	Pressure Building Regulator Adjustment
1	This procedure is best performed with a completely full tank, so that all changes in adjustment of the pressure building regulator will be reflected rapidly. Observe reading on pressure gauge (PI-1). If pressure is lower than desired set point of pressure building regulator/economizer regulator (PCV-1), proceed to Step 2; if higher, proceed to step 3.
2	If tank pressure is below the desired setting, loosen the pressure screw lock nut on the regulator. With PB Inlet and PB Outlet valves (HCV-3, HCV-11) open, gradually open regulator by turning the pressure screw (clockwise) to build tank pressure to the desired setting. Note that the pressure screw should be adjusted in small increments, allowing sufficient time for tank pressure to stabilize each time the screw is turned. The tank can be considered stabilized when no frost is found on the pressure building circuit. This reduces the possibility of over-shooting the desired pressure, which would in turn, require partial tank blow-down via the vent valve (HCV-12). Tighten lock nut on regulator, and return vessel to normal service.
3	If the tank is above the desired setting, open vent valve (HCV-12) to vent excess gas. Should pressure continue to rise above the desired level, proceed to step 4.
4	Again vent excess gas by opening vent valve (HCV-12). Reduce pressure until tank pressure gauge (PI-1) indicates a reading of 10 PSI (0.7 kg/cm ²) below the desired setting. Loosen set screw on PB regulator/economizer valve (PCV-1), and proceed to Step 2, gradually decrease tank pressure by adjusting the pressure screw (counter clockwise).

6 VESSEL HANDLING INSTRUCTIONS

Figures 1 and 2 depict two methods of handling vessels during installation. The handling method pictured in Figure 2 uses two cranes to place the tank. The two-crane method is the safer, and thus, more preferred method of installing the vessel. The alternate method of installation uses a single crane. This method is pictured in Figure 2.

FIGURE 1, TWO-CRANE INSTALLATION METHOD

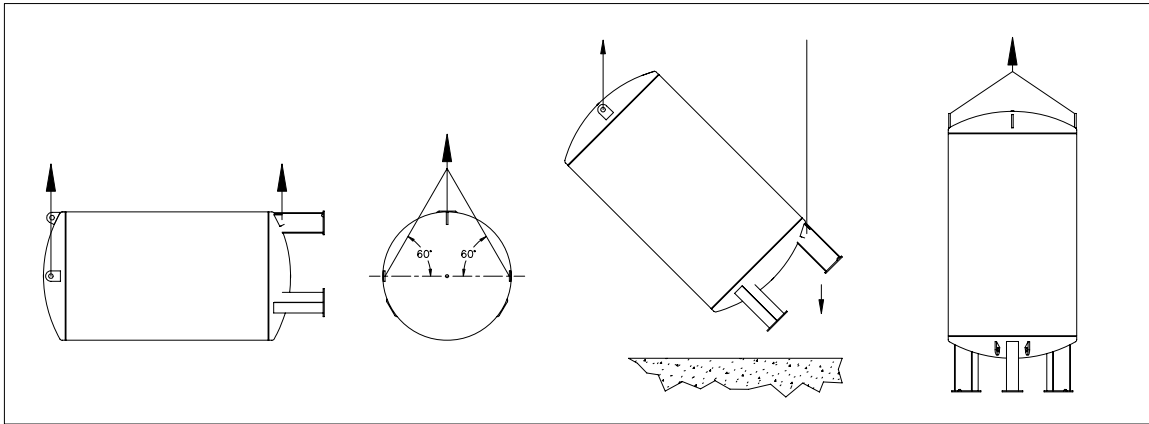
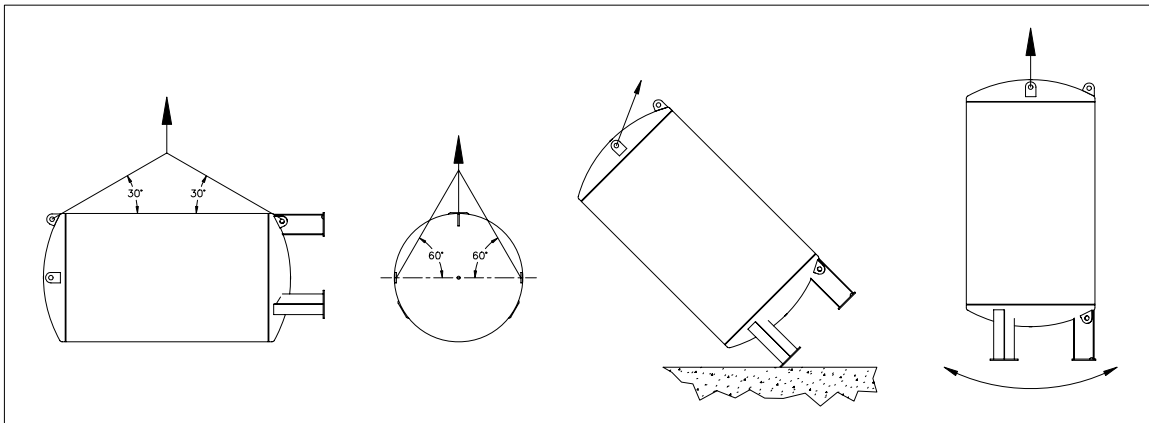

FIGURE 2, SINGLE-CRANE INSTALLATION METHOD



6.1 VESSEL TIE DOWN GUIDELINES

Chart Inc. Vessel Tie Down Guidelines

PURPOSE: TO BE GIVEN or SHOWN TO DRIVERS PRIOR TO LOADING IF POSSIBLE.

- Unless otherwise specified by customer, the tank should be orientated with the plumbed head pointing backward. The plumbing is less likely to be damaged during shipping in this orientation.
- Place supports or saddles on the head-shell seam, never in the middle of the head.
- Using appropriately sized element, tie the vessel to the bed of the trailer at the lifting lugs on the top of the vessel and at any lug clearly marked "Tie Down Only".
- If no lugs exist on the bottom portion of a vertical tank, tie the vessel to the bed of the trailer at the mounting holes on the leg pad. Attach elements to the vessel as close to the head as possible. If possible, avoid attaching chains to the outer part of the leg.
- A minimum of eight elements should be used to secure any vessel. The elements should be situated such that the tank cannot slide or roll in *any* direction.
- **Straps can cause damage to the tank finish. Avoid using straps to secure the vessel.**
- Under no circumstances should a chain, strap, or other tie down equipment that may damage the tank finish, come in direct contact with the outer shell of the vessel. Use rubber pad, corrugated cardboard or a similar material to protect the tank in areas where contact may occur. The trucker is responsible for providing these materials when required.
- If additional blocking is required due to placing the vessel partially over the drop section of the trailer, the trucker is responsible for providing that blocking.

Figure 1 below shows a side view of an acceptable element configuration for a conventional CHART vertical vessel.

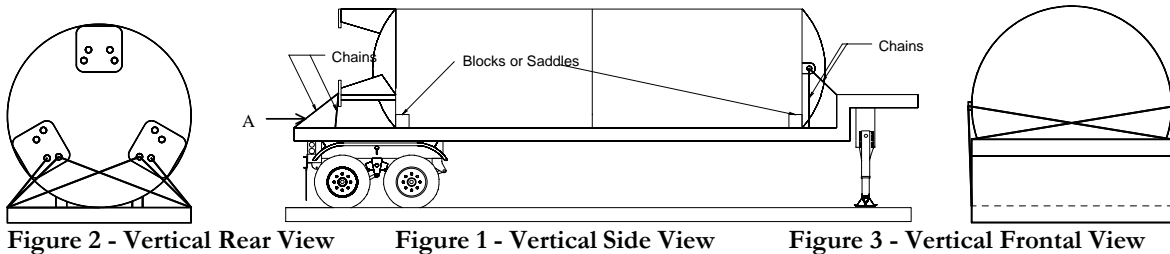

Figures 4 and 5 below show side and end views of a horizontal tank with tie down lugs on the saddle supports. The element configuration shown is acceptable for this type of vessel. If a tank is not equipped with tie down lugs on the saddle supports, use the holes in the saddle supports as tie down points. Use a chain configuration similar to the figure below.

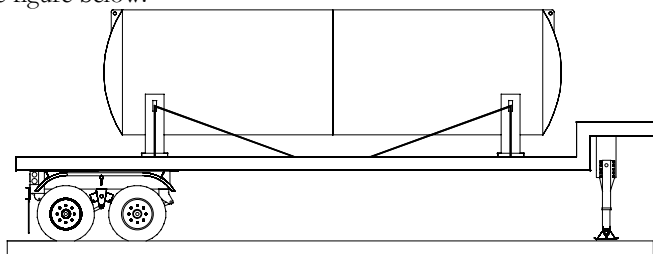

Figure 4 - Horizontal Side View

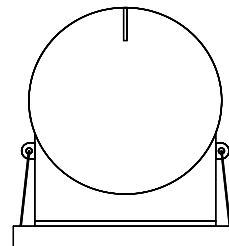

Figure 5 - Horizontal End View

CABLE AND CHAIN TABLE

Tank Size (gal)	Typ. Vessel Weight (lbs)	Maximum Force in Element (lbs)	Recommended Cable	Recommended Chain
1500	10000	17800	(1) 1/2" IWRC 6X19	(2) 1/2" Transport Grade 7
3000	17000	30600	(1) 3/4" IWRC 6X19	(3) 1/2" Transport Grade 7
6000	30000	53900	(1) 3/4" IWRC 6X19	(2) 7/8" Alloy Grade 8
9000	45000	66200	(2) 3/4" IWRC 6X19	(2) 7/8" Alloy Grade 8
11000	54000	79400	(2) 3/4" IWRC 6X19	(3) 7/8" Alloy Grade 8
13000	63000	92700	(2) 3/4" IWRC 6X19	(3) 7/8" Alloy Grade 8
15000	72000	106000	(2) 3/4" IWRC 6X19	(3) 7/8" Alloy Grade 8

This table shows **approximate** Chart tank sizes and weights. Tank sizes and volumes are based off of a standard 400 psi tank. Actual Tank weights may vary. Consult the data plate for the actual tank weight. The maximum force in any element is found from the weakest element on the vertical tank tie down configuration (Element "A"). If element "A" exceeds a 45 degree angle from horizontal the force in the element will exceed the value indicated in the table.

**** IT IS THE DRIVERS RESPONSIBILITY TO SECURE LOAD IN ACCORDANCE WITH DOT REGULATIONS.**

7 GENERAL

This chapter contains vessel maintenance information, including troubleshooting and repair procedures. Before performing any of the procedures in this chapter, be sure you are familiar with the location and function of controls and indicators discussed in other chapters.

7.1 MAINTENANCE

7.1.1 COMPATIBILITY AND CLEANING

It is essential to always keep the vessel clean and free of grease and oil. This is particularly important for units used in nitrogen and argon service since the temperature of liquid nitrogen or argon is below the liquefaction temperature of air; thus making it possible to condense liquid oxygen from air on the piping and vaporizer surfaces.

When replacing components, use only parts that are considered compatible with liquid oxygen and have been properly cleaned for oxygen service. (Refer to CGA Bulletin G4.1 “Equipment Cleaned for Oxygen Service”.) Do not use regulators, fittings, or hoses that were previously used in a compressed air environment. Only oxygen compatible sealants or virgin Teflon tape should be used on threaded fittings. All new joints should be leak tested with oxygen compatible leak test solution. When de-greasing parts use a suitable solvent for cleaning metallic parts.

7.1.2 PERIODIC INSPECTION

In order to maintain a cryogenic vessel in good operating condition, certain system components should be inspected on a periodic basis. Those components requiring periodic inspection are listed in this manual. In vessels being operated in areas having extreme hot or cold climates, inspection intervals should be shortened.

7.1.3 SOLDERING

Before performing any soldering work, always exhaust oxygen from oxygen lines and purge with nitrogen gas. Verify that lines are inert.

7.1.4 VACUUM INTEGRITY

These vessels are equipped with vacuum thermocouple gauge tubes and vacuum integrity may be tested with a vacuum meter. Deterioration or loss of vacuum will be apparent by cold spots, frost, or condensation on the jacket, or evidenced by abnormally rapid pressure buildup. Unless one of these conditions is evident, the vacuum level should not be suspected. In the event one of the above conditions exists, contact the factory for advice on vessel vacuum testing.

7.1.5 STORAGE

When a vessel is to be removed from service, it is essential to maintain cleanliness of the internal piping and pressure vessel. Follow the withdrawal procedures to empty the vessel of product and purge the vessel prior to storage. It is recommended to set up a routine inspection schedule to ensure a minimum positive pressure of 5 psi is maintained during storage. Ensure all atmospheric ports remain capped, plugged, or otherwise sealed to prevent moisture or debris ingress.

7.2 TROUBLESHOOTING

The Table 10 provides some troubleshooting procedures. The table is arranged in a Trouble/Probable Cause/Remedy format. Note that probable causes for specific problems are listed in descending order of significance. That is, check out the first cause listed before proceeding to the next. Repair procedures required, as listed in the remedy column, may be found in the Repair portion of this chapter. Perform procedures in order listed and exactly as stated (Refer to drawings as required to locate system components identified in the troubleshooting guide.)

7.3 REPAIR

CAUTION :

Plumbing should always be allowed to return to ambient temperature before repair work is performed. Vent or drain the vessel as necessary before replacing any component(s) exposed to pressure or to cryogenic liquid.

When repair of damaged components is required (in those instances when a spare part is not readily available), follow the instructions below.

When disassembly of an assembly is required, removed parts should be coded to facilitate reassembly. Reassembly of components should always be performed in the reverse manner in which they are disassembled. Parts removed during disassembly should be protected from damage, thoroughly cleaned, and stored in protective polyethylene bags if not immediately reinstalled. Clean all metal parts with a good industrial cleaning solvent. All rubber components should be washed in a soap and warm water solution. Air dry all cleaned parts using an oil-free, clean, low-pressure air source. Before reassembly, make sure that all parts are thoroughly cleaned and have been degreased. Cleaning will prevent valves and regulators from freezing while in service and prevent contamination of the liquid product.

When removing components from a vessel remember to always plug pipe openings as soon as they are exposed. Plastic pipe plugs of a clean plastic film may be used for this purpose.

7.4 VALVE REPAIR

When a defective valve is suspected, remove and repair the assembly as described in this manual. If a valve is leaking through the packing, tighten the packing nut first to see if the leakage will stop before removing the valve. Packing is best tightened when the valve is warm. If a safety relief valve fails, the defective assembly should be discarded and a new valve installed.

NOTE :

Globe valves used on containers vary in tube size from 1/4" to 2". While internal valve components may vary from valve to valve, the functional operation and repair procedures for these valves are the same.

Table 7 Valve Repair

STEP NUMBER	PROCEDURE
	<p style="text-align: center;">NOTE</p> <p>Unless valve component parts are available in inventory, a defective valve should be replaced with a new assembly.</p>
1	Release pressure in the vessel by opening vent valve (HCV-12).
2	Remove the valve seat assembly.
3	Disassemble the valve and inspect all piece parts
4	Clean all metallic parts with a good industrial cleaner, and all rubber & teflon parts in a warm water and soap solution.
5	Air dry all components using a clean low pressure air source.
6	Replace all worn, deformed or damaged parts.
7	<p>Repack the valve. Either preformed or twisted Teflon filament packing can be used. When using twisted Teflon filament packing, untwist Teflon and use only a single strand. Pack Teflon tightly; otherwise, moisture can get into the valve and freeze when the valve is cold.</p> <p>Reassemble the valve. Make sure that mating surfaces are clean and properly seated. If the repaired valve is not to be reinstalled immediately, seal it in a polyethylene bag for storage. Apply a label to the bag such as "CLEAN VALVE. DO NOT OPEN BAG UNLESS UNIT IS TO BE INSTALLED."</p>

7.5 REGULATOR REPAIR

When a defective pressure building regulator/ economizer regulator or final line regulator is identified, remove and repair the units as detailed in this manual.

NOTE :

Replacement regulators should be obtained from Chart to ensure compatibility.

Table 8 General Regulator Repair

STEP NUMBER	PROCEDURE
	<p>NOTE Unless regulator component parts are available in inventory, a defective regulator should be replaced with a new assembly.</p>
1	Release pressure in the vessel by opening vent valve (HCV-12).
2	Depressurize the regulator.
	<p style="text-align: center;">Single Regulator System</p> <p>a) For the pressure building/economizer regulator (PCV-1), this is accomplished by closing the pressure building inlet valve (HCV-3), the pressure building outlet valve (HCV-11), and the economizer isolation valve (HCV-17), and by loosening line relief valve (TSV-3). This relieves pressure on both the upstream and downstream sides of the regulator.</p> <p style="text-align: center;">Dual Regulator System</p> <p>b) For the pressure building (PCV-1) or economizer regulator (PCV-2), this is accomplished by closing the pressure building inlet valve (HCV-3), the pressure building outlet valve (HCV-11), and the economizer isolation valve (HCV-17), and by loosening line relief valves (TSV-3 and TSV-4). This relieves pressure on both the upstream and downstream sides of the regulators.</p> <p>c) For the final line regulator, this is accomplished by closing the two final line regulator isolation valves.</p>
3	It is possible that the body of the regulator is permanently installed in the vessel; in this case the seats, domes, pistons, springs, gaskets, etc. can be removed and replaced.
4	Disassemble the regulator, making sure to identify all piece parts removed.
5	Inspect all parts for wear, deformation, nicks, or damage. Replace all gaskets and O-rings.
6	Clean all metal parts with an industrial cleaning solvent. Air dry with a clean, low-pressure air source.
7	Reassemble the regulator in the reverse order of disassembly.
8	Bench test the rebuilt unit to make sure that it actuates properly at the set pressure. The pressure builder/economizer and final line regulators close to regulate downstream pressure.
9	If the regulator is to be reinstalled on a vessel, do so as soon as possible following repair. If it is to be returned to inventory, seal the unit in a polyethylene bag for storage. Apply a label to the bag such as "CLEAN REGULATOR, DO NOT OPEN BAG UNLESS UNIT IS TO BE INSTALLED. "
10	Pressurize the regulator by opening the applicable pressure building and isolation valves. Allow pressure to build up in the system and verify the reliability of the rebuilt unit.

7.6 GAUGE REPAIRS

Since a special instrument is normally required for making gauge repairs. It is advised that a defective gauge be replaced with a new unit and the defective one returned to your local Chart distributor or to the factory for repairs. However, before replacing a gauge there are a number of checks that can be performed.

CAUTION :

Before removing (or calibrating) the tank pressure gauge or liquid level gauge, make sure gauge isolation valves are closed and that the equalizing valve is open.

The major cause of gauge malfunction is a leakage in the gauge line. Therefore, as a first check, make certain that gauge lines are leak tight. Other gauge tests include:

1. Check gauge lines of obstructions.
2. Check leaky equalizer valve.
3. Ensure that connection lines are properly mated.
4. Verify that the gauge is properly zeroed.
5. Ensure that the pointer doesn't stick.

If the above checks fail to correct the problem, remove and replace the gauge. When returning the gauge to Chart for repair, indicate the nature of the difficulty experienced with the gauge in your letter of transmittal.

7.7 INNER TANK BURST DISC REPAIR

The tank burst disc is a safety relief device that will rupture completely to relieve inner tank pressure in the event tank relief valve fails or is unable to accommodate sufficient flow. Due to changes in pressure in the vessel, the disc will flex, gradually harden, embrittle, and consequently rupture at a lower pressure.

The following table serves to describe replacement of the inner vessel burst disc for vessels equipped with a dual relief system. In the event that a component needs to be replaced in the dual relief system, simply switch the selector handle to the other side of the safety system to allow routine maintenance and repair.

Table 9 Tank Burst Disc Replacement - Dual Safety System

STEP NUMBER	PROCEDURE
1	Switch selector valve (HCV-15) to other side, and depressurize the isolated side of the relief valve system, rather than venting vessel.
2	Remove burst disc (PSE-1) by opening HCV-16 if equipped. Or loosen PSE-1 allowing pressure to escape..
3	Install new burst disc (PSE-1), making sure that mating surfaces are clean and properly seated. Use an oxygen compatible liquid thread sealant to prevent leaking.

7.8 TESTING AFTER REPAIR

After making repairs requiring disassembly or part replacement, leak test all valves and piping joints that were taken apart and reconnected. Do not return the vessel to service until all leaks have been corrected or retested.

Table 10 Troubleshooting

PROBLEM	POSSIBLE CAUSE	DIAGNOSIS	SOLUTION
	1. Excessive shutdown time	1. User pattern	1. Replace vessel with more efficient model
	2. Low withdrawal rate	1. Frosting on economizer piping. No frosting on HCV-13 or Vap	1. Consult factory
	3. Tank gauge (PI-1) in error	1. Compare with gauge of known accuracy	1. Replace
*Pressure remains above economizer set point	4. Economizer not operating (tank above economizer set pressure)	1. No frost evident on pipe to HCV-17 & PCV-1.	1. Check if HCV-17 open
*Vessel vents through relief valve frequently	5. Leaking pressure building/economizer regulator (PCV-1)	1. Line to PCV-1 frosted from tank to HCV-3, and beyond	1. Check adjustment 2. Repair or replace
Excessive Tank Pressure Vessel	6. Inadequate vacuum	1. Take vacuum reading	Consult factory
Failure to maintain set delivery pressure	1. Pressure builder not operational	1. PB Valve Closed	1. PB Valve Open
*House pressure is low	2. Regulator set too low	1. No frosting on pipe to HCV-3, PCV-1 or PBC-1 2. Set pressure at or below final line pressure	1. Readjust
	3. Cannot maintain pressure	1. HCV-3, PCV-1 always frosted 2. Withdrawal too high	1. Install higher capacity PB system-consult factory
	4. Tank burst disc (PSE-1) ruptured	1. Flow can be felt at outlet of PSE-1	1. Replace
	5. Piping leak	1. Leak is audible	1. Replace
Erratic contents gauge reading	1. Needle is stuck	1. Tap gauge	1. Inspect pointer and bend if need be
	2. Needle binds	1. Tap gauge repeatedly	1. Replace gauge
	3. Needle does not adjust to "0"	1. Does not "0" when HCV-9 (equalizing valve) opened	1. Adjust
	4. Leaky gauge lines	1. Reading does not correspond to use	1. Tighten lines and fittings
	5. Incorrect span	1. Reading does not correspond to use	1. Reading does not correspond to use
	6. Valves not opened	1. Needle stays at "0"	1. Equalization valve closed (HCV-9) 2. Isolation valves (HCV-8 and HCV-10) open
	7. Reverse lines	1. Needle stays at "0"	1. Check stampings in gauge and vessel bottom "HP" corresponds to liquid phase
	8. Plugged line	1. Needle pegs, or moves very slowly	1. Consult factory

PROBLEM	POSSIBLE CAUSE	DIAGNOSIS	SOLUTION
Leaking relief valve	1. Ice under/in seat	1. Valve reseats when warming up	1. Warm and dry valve to prevent moisture accumulation
	2. Damaged seat	1. Valve does not re-seat	1. Replace valve
Ruptured tank burst disc	1. Excessive pressure	1. Relief valve damaged	1. Replace disc and valve
	2. Fatigue or corrosion	1. Environment	1. Replace disc
Inability to hold vacuum	1. Improper vacuum gauge change (voids warranty)	1. Measure vacuum rise in gauge assembly	1. Consult factory
	2. Internal/external leak	1. Vacuum rises in tank over short time	1. Consult factory
	3. Corroded safety disk (PSE-3)	1. Visual on helium leak test	1. Replace and re-pump
	4. Outgassing	1. Slow vacuum rise over long time	1. Re-pump

7.9 REGULATOR MAINTENANCE INSTRUCTIONS

PBE-1:

The Type PBE-1 regulator is designed for cryogenic service and combines the pressure building and economizer functions into one unit. In the Type PBE-1, the economizer function starts before the pressure build function stops. A restriction orifice limits the economizer output and prevents it from overpowering the pressure build function.

PBE-2:

The Type PBE-2 regulator is designed for cryogenic service and combines the pressure building and economizer functions into one unit. It is a direct acting, single seated, spring loaded diaphragm-type regulator. In the Type PBE-2, the economizer phase starts at the point at which the pressure build level is reached, thus assuring a smooth transition between the two functions.

DUAL REGULATORS

Dual regulators are designed for cryogenic service utilizing separate regulators for pressure building and economizer functions. This allows setting of greater pressure differences between these two regulated functions.

OPERATING INSTRUCTIONS

Adjusting the Delivery Pressure

The regulator's delivery pressure setting is adjusted by turning the adjusting screw at the top of the spring chamber after loosening the adjusting screw lock nut. To increase the delivery pressure, turn the adjusting screw clockwise (into the spring chamber). To decrease the delivery pressure, turn the adjusting screw counter-clockwise (out of the spring chamber). Tighten the adjusting screw lock nut after the adjusting has been made.

REPAIR KITS

REGULATOR PART NUMBER	REGULATOR		KIT PART NUMBER
	SIZE	MODEL	
11490623	1/4"	PBE-1	11656638
11490631	1/2"	PBE-2	11656700
2110032	1/4"	A-32	9715652
2110072	1/2"	TYPE B	10620123
11640353	1/2"	G-60-HP	11656734
11049205	1/4"	FRM	9715572
2111462	1/2"	FRM-2 HP	10620115

SPRINGS

REGULATOR	MODEL SIZE	SPRING PART NUMBER	RANGE (PSI)
PBE-1	1/4"	10525193	75-175
		10972348	150-350
PBE-2	1/2"	5710131	20-75
		10522363	25-125
		11525371	100-200
		10707392	150-250
A-32	1/4"	5710191	15-65
		5710111	40-100
		10525193	75-175
		5710201	100-250
TYPE B	1/2"	5710131	20-75
		10522363	25-125
		11525371	100-200
		10707392	150-250
G-60	1/2"	5710431	0-7
		5710371	5-70
		5710411	100-400
FRM	1/4"	5710031	2-25
		5710191	15-65
		5710111	40-100
		10525193	75-175
		5710201	100-250
FRM-2	1/2"	5710301	200-400

8 RECOMMENDED SPARES

8.1 11001551 RECOMMENDED SPARES 01 1"

Component	Description	Quantity
11509339	RPD ASSY 3/4"MPT*FREE 375PSI	1
11494835	RV BRZ 3/4MPT*1FPT 250 PSIG	1
1810802	RV BRS 1/4MPT 400PSI	1
11656638	KIT REPAIR REG PBE-1 W/CHECK	1
11819564	KIT REPAIR VLV FILL CHECK REGO	1
11819572	KIT REPAIR VLV FILL CHECK REGO	1
11819450	KIT REPAIR VLV BNT 1-1/2"ANGLE	1
11819468	KIT REPAIR VLV SEAT 1-1/2"ANGLE	1
11819425	KIT REPAIR VLV BNT 1/2-1" REGO	2
11819433	KIT REPAIR VLV SEAT 1/2-3/4"	1
11819441	KIT REPAIR VLV SEAT 1" REGO	1
11819521	KIT REPAIR VLV STEM 1/2-1/2"	1

8.2 11001560 RECOMMENDED SPARES 01 1-1/2"

Component	Description	Quantity
11494835	RV BRZ 3/4MPT*1FPT 250 PSIG	1
11509304	RPD ASSY 1"MPT*FREE 375PSI	1
1810802	RV BRS 1/4MPT 400PSI	1
11656700	KIT REPAIR REG PBE-2 W/CHECK	1
11819564	KIT REPAIR VLV FILL CHECK REGO	1
11819572	KIT REPAIR VLV FILL CHECK REGO	1
11819450	KIT REPAIR VLV BNT 1-1/2"ANGLE	1
11819468	KIT REPAIR VLV SEAT 1-1/2"ANGLE	1
11819425	KIT REPAIR VLV BNT 1/2-1" REGO	2
11819433	KIT REPAIR VLV SEAT 1/2-3/4"	1
11819441	KIT REPAIR VLV SEAT 1" REGO	1
11819521	KIT REPAIR VLV STEM 1/2-1/2"	1

8.3 11060068 RECOMMENDED SPARES DSS 1"

Component	Description	Quantity
11509339	RPD ASSY 3/4"MPT*FREE 375PSI	1
11494835	RV BRZ 3/4MPT*1FPT 250 PSIG	1
1810802	RV BRS 1/4MPT 400PSI	1
9715652	KIT REPAIR PB REG VGL-160	1
9715572	KIT REPAIR REG 1/4" TYPE FRM	1
11819564	KIT REPAIR VLV FILL CHECK REGO	1
11819572	KIT REPAIR VLV FILL CHECK REGO	1
11819450	KIT REPAIR VLV BNT 1-1/2"ANGLE	1
11819468	KIT REPAIR VLV SEAT 1-1/2"ANGLE	1
11819425	KIT REPAIR VLV BNT 1/2-1" REGO	2
11819433	KIT REPAIR VLV SEAT 1/2-3/4"	1
11819548	KIT REPAIR VLV STEM 1/4-1/2"	1
11819441	KIT REPAIR VLV SEAT 1" REGO	1

8.4 11882379 RECOMMENDED SPARES DSS 1-1/2"

Component	Description	Quantity
11494835	RV BRZ 3/4MPT*1FPT 250 PSIG	1
11509304	RPD ASSY 1"MPT*FREE 375PSI	1
1810802	RV BRS 1/4MPT 400PSI	1
10620123	KIT REPAIR REG B 1/2"	1
9715572	KIT REPAIR REG 1/4" TYPE FRM	1
11819564	KIT REPAIR VLV FILL CHECK REGO	1
11819572	KIT REPAIR VLV FILL CHECK REGO	1
11819468	KIT REPAIR VLV SEAT 1-1/2"ANGLE	1
11819450	KIT REPAIR VLV BNT 1-1/2"ANGLE	1
11819425	KIT REPAIR VLV BNT 1/2-1" REGO	2
11819433	KIT REPAIR VLV SEAT 1/2-3/4"	1
11819441	KIT REPAIR VLV SEAT 1" REGO	1
11819548	KIT REPAIR VLV STEM 1/4-1/2"	1

8.5 LIQUID LEVEL CHARTS

9 DRAWINGS

Outline & Dimension	
VS-525-1500	C-14190861
VS-3000-6000	C-14190870
VS-9000-15000	C-14190888
HS-1500	C-14190896
HS-3000-6000	C-14190909
HS-9000-15000	C-14190917

Process & Instrument Diagram (UNIT SPECIFIC)

INNER VESSEL DESIGN DATA				
Model:	VS-525 / 900 / 1500			
MAWP:	PSIG	250	400	500
	barg	17.24	27.58	34.47
DESIGN PRESSURE	PSIG	272.4	422.4	522.4
	barg	18.78	29.12	36.02
CODE COMPLIANCE: ASME CODE CASE 2596				
DESIGN TEMPERATURE	°F	-32° TO 120°		
	°C	-196° TO 49°		
MATERIAL OF CONSTRUCTION: SA240 304 STAINLESS STEEL				
OUTER VESSEL DATA				
CODE COMPLIANCE: FULL VACUUM PER CGA-341				
DESIGN TEMPERATURE	°F	-20° TO 300°		
	°C	-29° TO 149°		
MATERIAL OF CONSTRUCTION: A36 CARBON STEEL				
INSULATION TYPE: VACUUM AND MULTILAYER INSULATION				
EVACUATION CONNECTION: 3-1/2" PUMPOUT PORT				
VACUUM GAUGE CONNECTION: HASTINGS DV6R				
BUILDING CODE				
DESIGNED FOR CURRENT BUILDING CODE SEE CHART POLICY #NP-180				

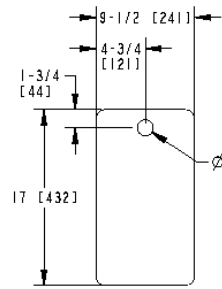

FOOT PAD
1-1/4 [32] THK
TYP 3 PLCS

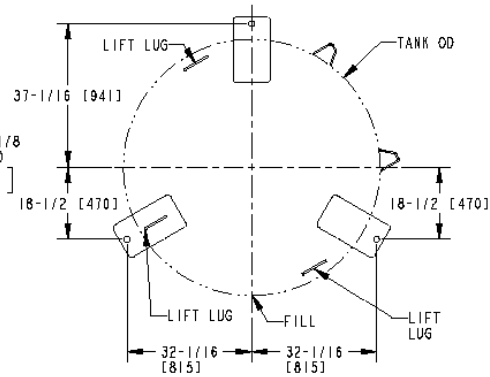

BOLT HOLE LAYOUT
TOP VIEW
SCALE: N/A

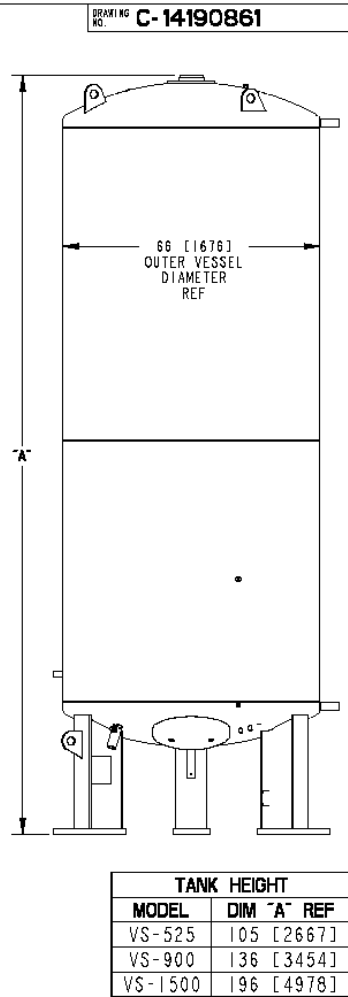

WEIGHTS AND SHIPPING DATA											
MODEL:		VS-525			VS-900			VS-1500			
MAWP	PSIG	250	400	500	250	400	500	250	400	500	
	barg	17.24	27.58	34.47	17.24	27.58	34.47	17.24	27.58	34.47	
WEIGHT EMPTY	POUNDS	3,300	4,000	4,500	4,400	5,100	5,800	6,100	7,600	8,700	
	KILOGRAMS	1,497	1,814	2,041	1,996	2,313	2,631	2,767	3,447	3,946	
WEIGHT FULL	OXYGEN	POUNDS	8,300	9,000	9,500	12,700	13,400	14,100	21,600	23,000	24,100
		KILOGRAMS	3,765	4,082	4,309	5,761	6,078	6,396	9,798	10,433	10,932
	NITROGEN	POUNDS	6,800	7,500	8,000	10,300	11,000	11,700	17,100	18,500	19,600
		KILOGRAMS	3,084	3,402	3,629	4,672	4,990	5,307	7,756	8,391	8,890
	ARGON	POUNDS	9,400	10,100	10,600	14,500	15,200	15,900	25,000	26,400	27,500
		KILOGRAMS	4,264	4,581	4,808	6,577	6,895	7,212	11,340	11,975	12,474
SHIPPING DIMENSIONS	INCHES	105 X 85 X 75			136 X 85 X 75			196 X 85 X 75			
	MM'S	2,667 X 2,159 X 1,905			3,454 X 2,159 X 1,905			4,978 X 2,159 X 1,905			

CAPACITIES					
MODEL:		VS-525	VS-900	VS-1500	
CAPACITY	GROSS GALLONS	570	940	1,640	
	(COLD) LITERS	2,158	3,558	6,208	
	NET GALLONS	510	850	1,580	
	(COLD) LITERS	1,931	3,218	5,981	
GASES EQUIVALENT AT 1 ATM AND 70°F / 1 ATM AND 21°C	OXYGEN	SCF	58,800	97,900	181,900
		NM3	1,665	2,772	5,151
	NITROGEN	SCF	47,500	79,200	147,200
		NM3	1,345	2,243	4,168
	ARGON	SCF	57,400	95,700	177,800
		NM3	1,625	2,710	5,035

IN[mm]

REV	ECR NO	REVISION DESCRIPTION	BY	DATE	APPROVED	DATE
					JJC	10-7-08
					MMK	10-8-08
					KJR	10-15-08
					DML	10-22-08
					RC	10-8-08
					JK	10-13-08

SEE B.O.M.

UNLESS OTHERWISE SPECIFIED DIMENSIONS ARE IN INCHES. TOLERANCES: FRACTIONS ± 1/8 ANGLES ± 2 PLACE DECIMALS ± NA 3 PLACE DECIMALS ± NA

PART NUMBER
14190861

THE MATERIALS AND INFORMATION, INCLUDING THE PRINCIPLES OF DESIGN CONTAINED IN THIS PRINT, IS THE EXCLUSIVE PROPERTY OF CHART, INC., AND IS CONFIDENTIAL AND PROPRIETARY INFORMATION. THIS INFORMATION MAY NOT BE REPRODUCED, COPIED, OR LOANED, IN PART OR IN WHOLE, NOR IS THE INFORMATION TO BE RELATED TO ANY PARTY WITHOUT CHART'S PRIOR WRITTEN CONSENT.

APPROVED: JJC DATE: 10-7-08
 NEXT ASS'Y: MMK USED ON: 10-8-08
 APPLICATION: KJR QUANTITY REQ'D: 10-15-08
 DATE: DML 10-22-08
 DATE: RC 10-8-08
 DATE: JK 10-13-08

VS-525/900/1500 SS COLD STRETCH 250/400/500PSI

DRAWING NO. **C-14190861** REV
 SCALE: 1/32"=1" DO NOT SCALE DRAWING SHEET 1 OF 1

INNER VESSEL DESIGN DATA					
Model	VS-3000 THRU 6000				
MAWP:	PSIG	175	250	400	500
	barg	12.07	17.24	27.58	34.47
DESIGN PRESSURE	PSIG	206.3	281.3	431.3	531.3
	barg	14.23	19.39	29.74	36.63
CODE COMPLIANCE:	ASME CODE CASE 2596				
DESIGN TEMPERATURE	°F	-320° TO 120°			
	°C	-196° TO 49°			
MATERIAL OF CONSTRUCTION:	SA240 304 STAINLESS STEEL				
OUTER VESSEL DATA					
CODE COMPLIANCE:	FULL VACUUM PER CGA-341				
DESIGN TEMPERATURE	°F	-20° TO 300°			
	°C	-29° TO 149°			
MATERIAL OF CONSTRUCTION:	A36 CARBON STEEL				
INSULATION TYPE:	VACUUM AND MULTILAYER INSULATION				
EVACUATION CONNECTION:	3-1/2" PUMPOUT PORT				
VACUUM GAUGE CONNECTION:	HASTINGS DV6R				
BUILDING CODE					
DESIGNED FOR CURRENT BUILDING CODE SEE CHART POLICY #NP-180					

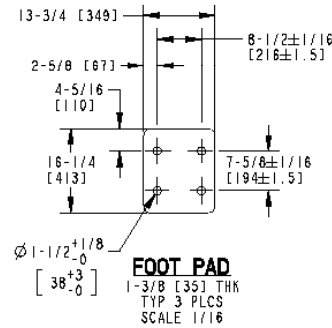
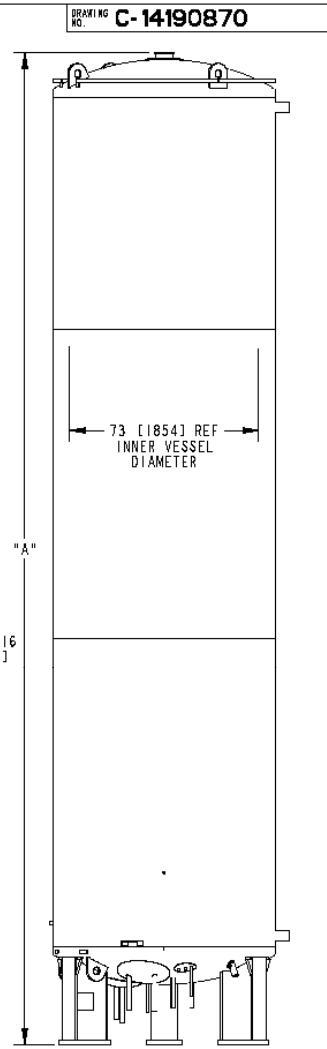
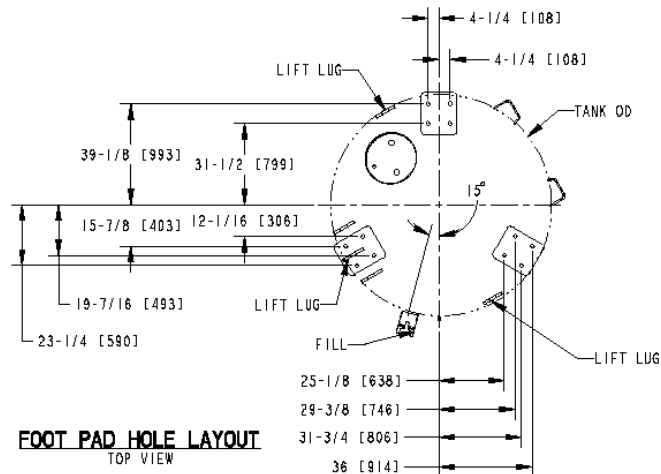

TANK HEIGHT	
MODEL	DIM "A" REF
VS-3000	228 [5791]
VS-6000	383 [9728]

WEIGHTS AND SHIPPING DATA										
MODEL:		VS-3000				VS-6000				
MAWP	PSIG	175	250	400	500	175	250	400	500	
		barg	12.07	17.24	27.58	34.47	12.07	17.24	27.58	34.47
WEIGHT EMPTY	POUNDS	10,900	12,600	15,100	15,100	19,800	21,300	27,000	27,100	
	KILOGRAMS	4,944	5,715	6,849	6,849	8,891	9,662	12,247	12,292	
WEIGHT FULL	OXYGEN	POUNDS	40,600	42,200	44,700	44,700	76,200	77,800	83,500	83,600
		KILOGRAMS	18,416	19,142	20,276	20,276	34,564	35,289	37,875	37,920
	NITROGEN	POUNDS	31,900	33,600	36,100	36,100	59,700	61,300	67,000	67,100
		KILOGRAMS	14,470	15,241	16,375	16,375	27,079	27,805	30,391	30,436
	ARGON	POUNDS	47,100	48,800	51,300	51,300	88,700	90,300	96,000	96,100
		KILOGRAMS	21,364	22,135	23,269	23,269	40,234	40,959	43,545	43,590
SHIPPING DIMENSIONS	INCHES (L * W * H)	228 x 86 x 86				383 x 86 x 86				
	MM'S (L * W * H)	5,791 x 2,184 x 2,184				9,728 x 2,184 x 2,184				

CAPACITIES					
MODEL:		VS-3000	VS-6000		
CAPACITY	GROSS	GALLONS	3,150	6,010	
	(COLD)	LITERS	11,924	22,750	
	NET	GALLONS	3,030	5,770	
	(COLD)	LITERS	11,470	21,842	
GASES EQUIVALENT AT 1 ATM AND 70°F / 1 ATM AND 0°C	OXYGEN	SCF	348,800	664,200	
		NM3	9,877	18,808	
	NITROGEN	SCF	282,200	537,300	
		NM3	7,991	15,215	
	ARGON	SCF	340,900	649,200	
		NM3	9,653	18,383	

IN(mm)

REV	ECR NO	REVISION DESCRIPTION	BY	DATE	APPROVED	DATE			
					MMK	10-7-08			
					MMK	10-8-08	NEXT ASS'Y	USED ON	NEXT ASS'Y
					KJR	10-15-08	APPLICATION		QUANTITY REQ'D
					DML	10-22-08	Distribution & Storage Group New Prague Operations		
					RC	10-8-08			
					JK	10-13-08	VS-3000 THRU 6000 SS COLD STRETCH 175/250/400/500PSI		
THE MATERIALS AND INFORMATION, INCLUDING THE PRINCIPLES OF DESIGN CONTAINED IN THIS PRINT, IS THE EXCLUSIVE PROPERTY OF CHART INC., AND IS CONFIDENTIAL AND PROPRIETARY INFORMATION. THIS INFORMATION MAY NOT BE REPRODUCED, COPIED, OR LOANED, IN PART OR IN WHOLE, NOR IS THE INFORMATION TO BE RELATED TO ANY PARTY WITHOUT CHART'S PRIOR WRITTEN CONSENT.					PART NUMBER 14190870		UNLESS OTHERWISE SPECIFIED DIMENSIONS ARE IN INCHES. TOLERANCES: FRACTIONS ± 1/8 ANGLES ± 2 PLACE DECIMALS ± NA 3 PLACE DECIMALS ± NA		
DRAWING NO. C-14190870							SCALE	DO NOT SCALE DRAWING	SHEET 1 OF 1

WEIGHTS AND SHIPPING DATA														
MODEL:		VS-9000			VS-1000			VS-13000			VS-15000			
MAWP	PSIG	175	250	400	175	250	400	175	250	400	175	250	400	
		barg	12.07	17.24	27.58	12.07	17.24	27.58	12.07	17.24	27.58	12.07	17.24	27.58
WEIGHT EMPTY	POUNDS	29,100	32,000	38,900	34,900	38,200	46,700	41,300	45,200	55,100	47,600	52,000	63,400	
	KILOGRAMS	13,200	14,515	17,645	15,830	17,327	21,183	18,733	20,502	24,993	21,591	23,587	28,758	
WEIGHT FULL	OXYGEN	POUNDS	117,200	120,000	127,000	142,400	145,700	154,100	169,500	173,300	183,200	195,400	199,700	211,100
		KILOGRAMS	53,161	54,431	57,606	64,592	66,088	69,899	76,884	78,608	83,098	88,632	90,582	95,753
	NITROGEN	POUNDS	91,500	94,300	101,300	111,000	114,300	122,800	132,100	135,900	145,800	152,200	156,600	168,000
		KILOGRAMS	41,504	42,774	45,949	50,349	51,846	55,701	59,920	61,643	66,134	69,037	71,033	76,204
	ARGON	POUNDS	136,600	139,400	146,400	166,100	169,400	177,900	197,800	201,600	211,500	228,000	232,400	243,700
		KILOGRAMS	61,961	63,231	66,406	75,342	76,839	80,694	89,721	91,444	95,935	103,419	105,415	110,540
SHIPPING DIMENSIONS	INCHES (L * W * H)	348 x 114.2 x 114.2			407 x 114.2 x 114.2			466 x 114.2 x 114.2			525 x 114.2 x 114.2			
	MM'S (L * W * H)	8,840 x 2,901 x 2,901			10,338 x 2,901 x 2,901			11,837 x 2,901 x 2,901			13,335 x 2,901 x 2,901			

CAPACITIES						
MODEL:		VS-9000	VS-1000	VS-13000	VS-15000	
CAPACITY	GROSS GALLONS	9,360	11,410	13,470	15,520	
	(COLD) LITERS	35,431	43,192	50,989	58,750	
	NET GALLONS	8,990	10,960	13,060	15,060	
	(COLD) LITERS	34,031	41,488	49,437	57,008	
GASES EQUIVALENT AT 1 ATM AND 70°F / 1 ATM AND 0°C	OXYGEN	SCF	1,034,800	1,261,500	1,503,300	1,733,500
		NM3	29,302	35,722	42,569	49,087
	NITROGEN	SCF	837,100	1,020,500	1,216,100	1,402,300
		NM3	23,704	28,897	34,436	39,709
	ARGON	SCF	1,011,400	1,233,000	1,469,300	1,694,300
		NM3	28,640	34,915	41,606	47,977

INNER VESSEL DESIGN DATA				
Model	VS-9000 THRU 15000			
MAWP:	PSIG	175	250	400
	barg	12.07	17.24	27.58
DESIGN PRESSURE	PSIG	213.5	288.5	438.5
	barg	14.72	19.89	30.23
CODE COMPLIANCE:	ASME CODE CASE 2596			
DESIGN TEMPERATURE	°F	-320° TO 120°		
	°C	-196° TO 49°		
MATERIAL OF CONSTRUCTION:	SA240 304 STAINLESS STEEL			
OUTER VESSEL DATA				
CODE COMPLIANCE:	FULL VACUUM PER CGA-341			
DESIGN TEMPERATURE	°F	-20° TO 300°		
	°C	-29° TO 149°		
MATERIAL OF CONSTRUCTION:	A36 CARBON STEEL			
INSULATION TYPE:	VACUUM AND MULTILAYER INSULATION			
EVACUATION CONNECTION:	3-1/2" PUMPOUT PORT			
VACUUM GAUGE CONNECTION:	HASTINGS DVR6			
BUILDING CODE:				
DESIGNED FOR CURRENT BUILDING CODE SEE CHART POLICY #NP-180				

TANK HEIGHT	
MODEL	DIM "A" REF
VS-9000	348 [8840]
VS-11000	407 [10338]
VS-13000	466 [11837]
VS-15000	525 [13335]

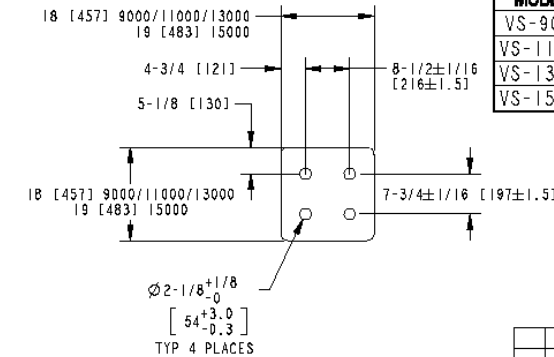

FOOT PAD
 1-5/8 [42] THK 9000/11000/13000
 1-7/8 [48] THK 15000
 SCALE 1/16
 TYP (3) PLCS

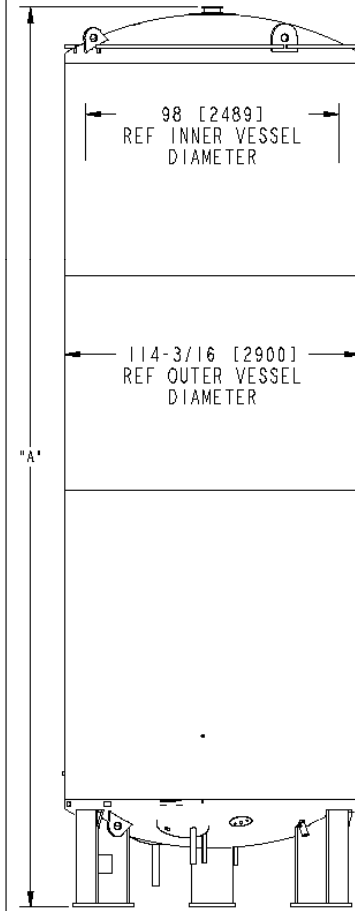

REV	ECR NO	REVISION DESCRIPTION	BY	DATE	APPROVED	DATE	QUANTITY REQ'D
					BY: JJC	10-7-08	
					BY: MMK	10-8-08	NEXT ASS'Y USED ON
					BY: KJR	10-15-08	APPLICATION
					BY: DML	10-22-08	QUANTITY REQ'D
					BY: RC	10-8-08	
					BY: JK	10-13-08	
					UNLESS OTHERWISE SPECIFIED DIMENSIONS ARE IN INCHES. TOLERANCES: FRACTIONS ± 1/8 DECIMALS ± .010 2 PLACE DECIMALS ± .005 3 PLACE DECIMALS ± .001		
					PART NUMBER 14190888		
					DRAWING NO. C-14190888		
					SCALE 1/32"=1" DO NOT SCALE SHEET 1 OF 2		

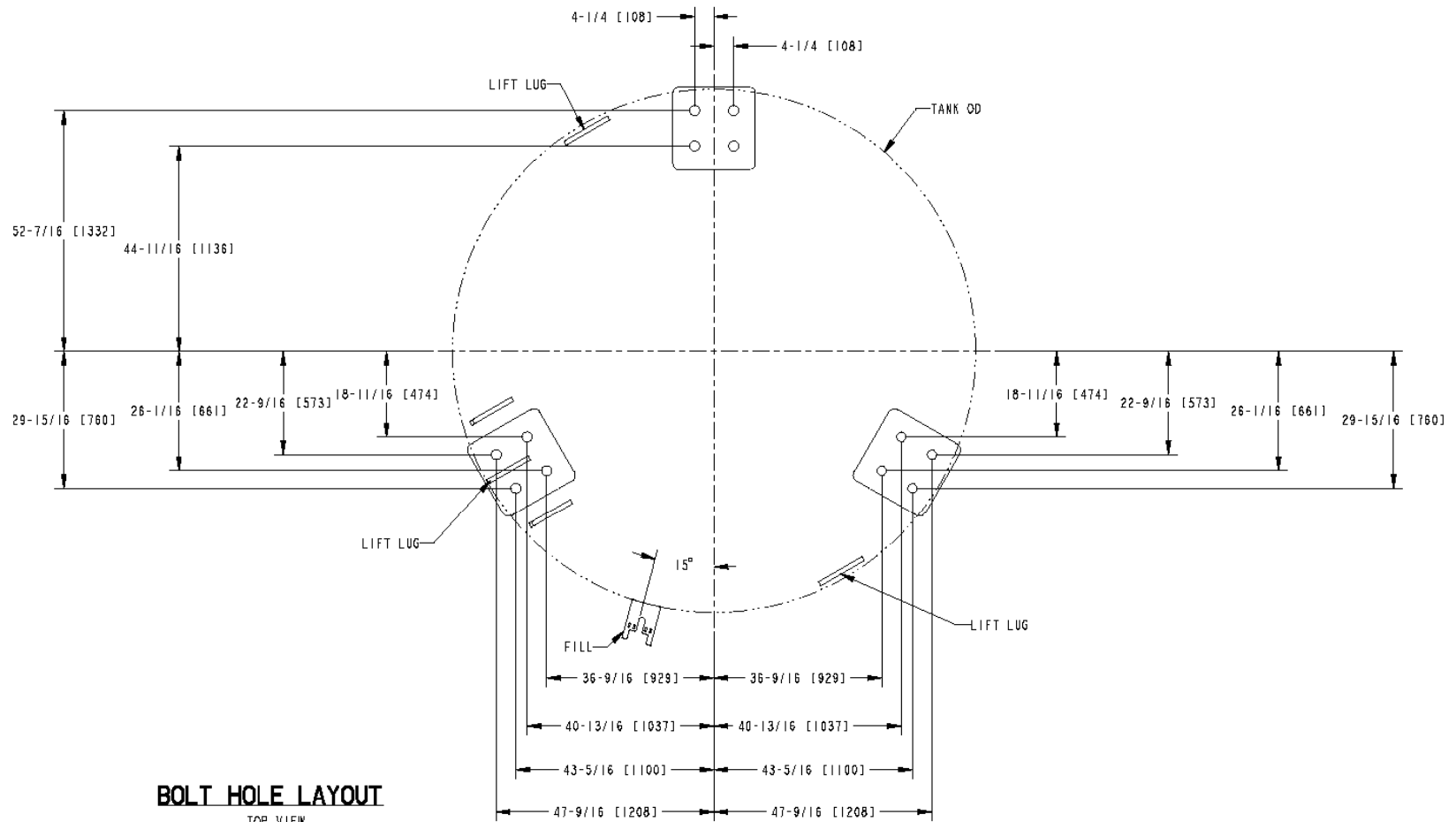

BOLT HOLE LAYOUT
TOP VIEW
SCALE NA

APPROVED	DATE			
DRAWN BY: JJC	10-7-08	NEXT ASS'Y	USED ON	
REV'D BY:		APPLICATION	QUANTITY REQ'D	
WFL: ECR:		 Distribution & Storage Group New Prague Operations		
PRG: CHG:				
REV	ECR NO	REVISION DESCRIPTION	BY	DATE
		THE MATERIALS AND INFORMATION, INCLUDING THE PRINCIPLES OF DESIGN CONTAINED IN THIS PRINT, IS THE EXCLUSIVE PROPERTY OF CHART INC., AND IS CONFIDENTIAL AND PROPRIETARY INFORMATION. THIS INFORMATION MAY NOT BE REPRODUCED, COPIED, OR LOANED, IN PART OR IN WHOLE, NOR IS THE INFORMATION TO BE RELATED TO ANY PARTY WITHOUT CHART'S PRIOR WRITTEN CONSENT.	MAT'L	SEE B.O.M.
			PART NUMBER	14190888
UNLESS OTHERWISE SPECIFIED DIMENSIONS ARE IN INCHES.		380 VS-9000 THRU 15000 SS COLD STRETCH 175/250/400PSI		
TOLERANCES:		DRAWING NO. C-14190888		
FRACTIONS ± 1/8		REV		
ANGLES ±		SCALE 1/16"=1"		
2 PLACE DECIMALS ± NA		DO NOT SCALE DRAWING		
3 PLACE DECIMALS ± NA		SHEET 2 OF 2		

DRAWING NO. **C-14190896**

INNER VESSEL DESIGN DATA		
MODEL:	HS-1500	
MAWP:	PSIG	250
	barg	17.24
DESIGN PRESSURE	PSIG	272.4
	barg	18.78
CODE COMPLIANCE: ASME CODE CASE 2596		
DESIGN TEMPERATURE	°F	-320° TO 120°
	°C	-196° TO 49°
MATERIAL OF CONSTRUCTION: SA240 304 STAINLESS STEEL		
OUTER VESSEL DATA		
CODE COMPLIANCE: FULL VACUUM PER CGA-341		
DESIGN TEMPERATURE	°F	-20° TO 300°
	°C	-29° TO 149°
MATERIAL OF CONSTRUCTION: A36 CARBON STEEL		
INSULATION TYPE: VACUUM AND MULTILAYER INSULATION		
EVACUATION CONNECTION: 3-1/2" PUMPOUT PORT		
VACUUM GAUGE CONNECTION: HASTINGS DV6R		
BUILDING CODE: DESIGNED FOR CURRENT BUILDING CODE SEE CHART POLICY #NP-180		

WEIGHTS AND SHIPPING DATA			
MODEL:	HS-1500		
MAWP	PSIG	250	
	barg	17.24	
WEIGHT EMPTY	POUNDS	6,700	
	KILOGRAMS	3,039	
WEIGHT FULL	OXYGEN	POUNDS	22,200
		KILOGRAMS	10,070
	NITROGEN	POUNDS	17,700
		KILOGRAMS	8,029
	ARGON	POUNDS	25,600
		KILOGRAMS	11,612
SHIPPING DIMENSIONS	INCHES	201 X 85 X 75	
	MM'S	5,105 X 2,159 X 1,905	

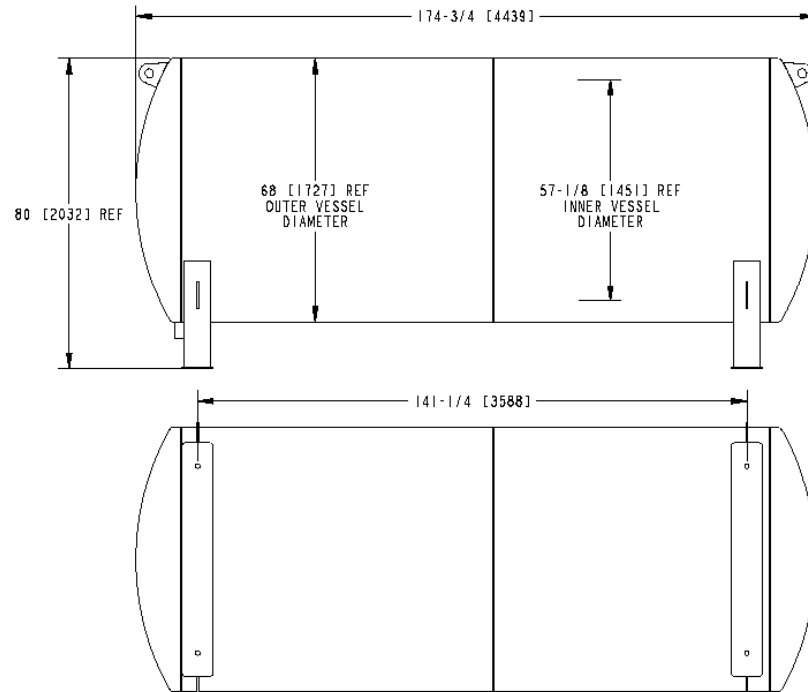
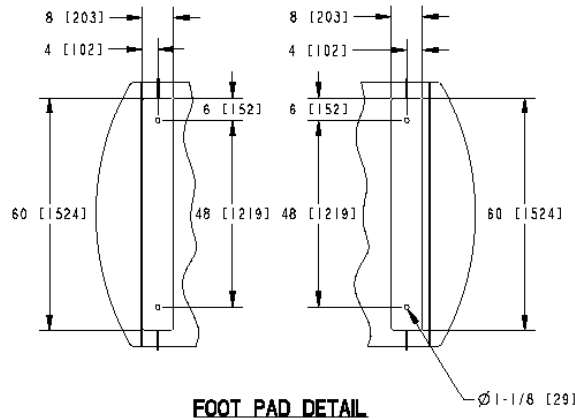

CAPACITIES			
MODEL:		HS-1500	
CAPACITY	(COLD)	GALLONS	1,640
		LITERS	6,208
	(COLD)	GALLONS	1,580
		LITERS	5,981
GASES EQUIVALENT AT 1 ATM AND 70°F / 1 ATM AND 0°C	OXYGEN	SCF	181,900
		NM3	5,151
	NITROGEN	SCF	147,200
		NM3	4,168
	ARGON	SCF	177,800
		NM3	5,035

				APPROVED	DATE					
				BY: JJC	10-28-08					
				BY: MMK	10-28-08	NEXT ASS'Y	USED ON	NEXT ASS'Y	QTY REQ'D	
A	13874	CHG DRAWING PER ECR	JJC	11-24-08	BY: KJR	10-29-08	APPLICATION		QUANTITY	REQ'D
REV	ECR NO	REVISION DESCRIPTION	BY	DATE	BY: DML	11-5-08				
				BY: RC	10-30-08	Distribution & Storage Group New Prague Operations				
				BY: JK	10-30-08					
				UNLESS OTHERWISE SPECIFIED DIMENSIONS ARE IN INCHES. TOLERANCES: FRACTIONS ± 1/4						
				PART NUMBER		DRAWING NO.		REV		
				14190896		C-14190896		A		
				UNLESS OTHERWISE SPECIFIED DIMENSIONS ARE IN INCHES. TOLERANCES: FRACTIONS ± 1/4		SCALE		DO NOT SCALE		SHEET
				2 PLACE DECIMALS ± NA		3/64" = 1"		DRAWING		1 OF 1
				3 PLACE DECIMALS ± NA						

IN[mm]

INNER VESSEL DESIGN DATA			
Model	HS-3000 THRU 6000		
MAWP:	PSIG	175	250
	barg	12.07	17.24
DESIGN PRESSURE	PSIG	206.3	281.3
	barg	14.23	19.39
CODE COMPLIANCE:	ASME CODE CASE 2596		
DESIGN TEMPERATURE	°F	-320° TO 120°	
	°C	-196° TO 49°	
MATERIAL OF CONSTRUCTION:	SA240 304 STAINLESS STEEL		
OUTER VESSEL DATA			
CODE COMPLIANCE:	FULL VACUUM PER CGA-341		
DESIGN TEMPERATURE	°F	-20° TO 300°	
	°C	-29° TO 149°	
MATERIAL OF CONSTRUCTION:	A36 CARBON STEEL		
INSULATION TYPE:	VACUUM AND MULTILAYER INSULATION		
EVAUATION CONNECTION:	3-1/2" PUMPOUT PORT		
VACUUM GAUGE CONNECTION:	HASTINGS DV6R		
BUILDING CODE:			
DESIGNED FOR CURRENT BUILDING CODE SEE CHART POLICY #NP-180			

TANK LENGTH	
MODEL	DIM "A" REF
HS-3000	206-5/8[5,249]
HS-6000	359-1/2[9,132]

SADDLE LENGTH	
MODEL	DIM "B" REF
HS-3000	166[4,216]
HS-6000	318[8,077]

WEIGHTS AND SHIPPING DATA						
MAWP	MODEL:	HS-3000		HS-6000		
	PSIG	175	250	175	250	
WEIGHT EMPTY	barg	12.07	17.24	12.07	17.24	
	POUNDS	10,900	11,700	20,300	21,700	
WEIGHT FULL	KILOGRAMS		4,944	5,307	9,208	9,843
	OXYGEN	POUNDS	40,500	41,300	79,000	80,500
		KILOGRAMS	18,370	18,733	35,834	36,514
	NITROGEN	POUNDS	31,800	32,700	61,900	63,300
		KILOGRAMS	14,424	14,832	28,077	28,712
	ARGON	POUNDS	47,000	47,900	92,000	93,500
KILOGRAMS		21,319	21,727	41,730	42,411	
SHIPPING DIMENSIONS	INCHES (L * W * H)	233 x 86 x 95		386 x 86 x 95		
	MM'S (L * W * H)	5,913 x 2,184 x 2,413		9,805 x 2,184 x 2,413		

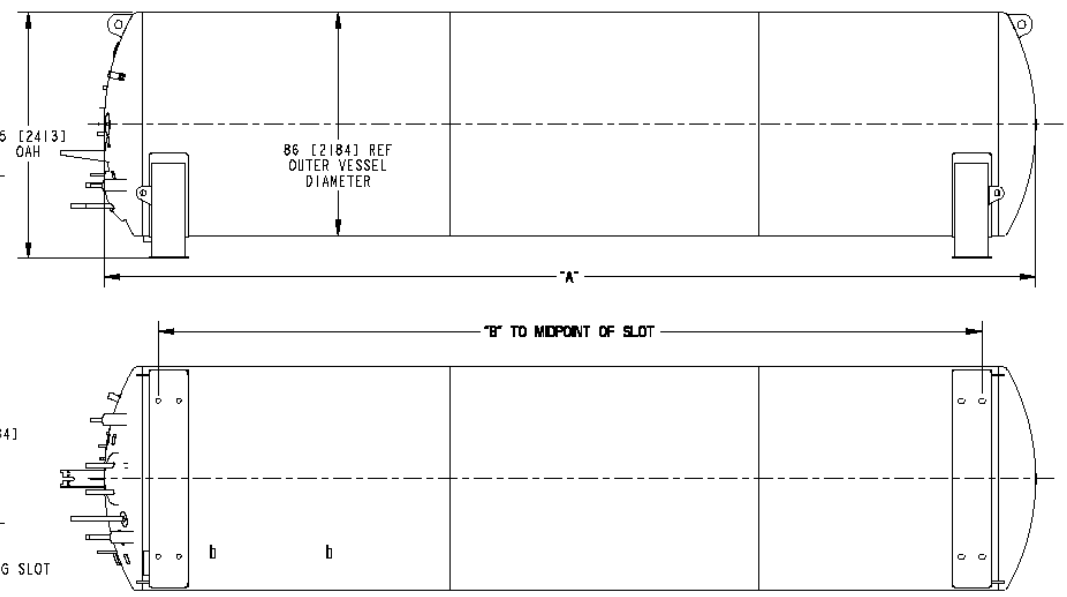
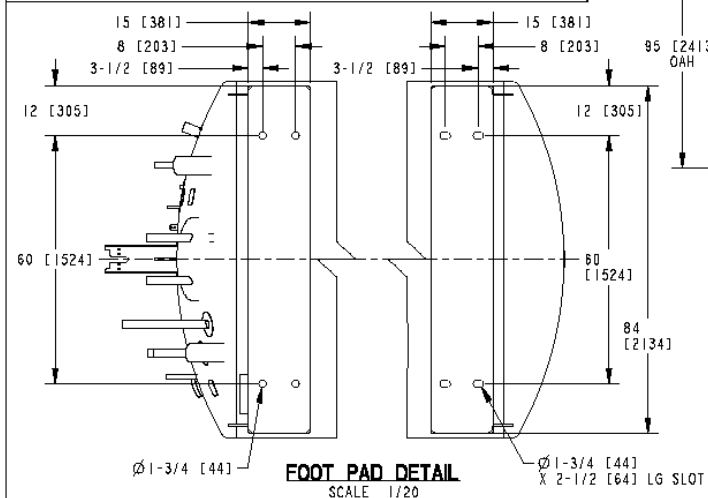

CAPACITIES				
CAPACITY	MODEL:	HS-3000		HS-6000
	GASES EQUIVALENT AT 1 ATM AND 70°F / 1 ATM AND 0°C	OXYGEN	GROSS GALLONS	3,150
(COLD) LITERS			11,924	22,750
NITROGEN		NET GALLONS	3,030	5,770
		(COLD) LITERS	11,470	21,842
GASES EQUIVALENT AT 1 ATM AND 70°F / 1 ATM AND 0°C	ARGON	SCF	348,800	664,200
		NM3	9,877	18,808
	NITROGEN	SCF	282,200	537,300
		NM3	7,991	15,215
ARGON	SCF	340,900	649,200	
	NM3	9,653	18,383	

REV	ECR NO	REVISION DESCRIPTION	BY	DATE	APPROVED	DATE
					JJC	10-13-08
					MMK	10-14-08
					KJR	10-15-08
					DML	10-22-08
					RC	10-14-08
					JK	10-16-08

THE MATERIALS AND INFORMATION, INCLUDING THE PRINCIPLES OF DESIGN CONTAINED IN THIS PRINT, IS THE EXCLUSIVE PROPERTY OF CHART, INC., AND IS CONFIDENTIAL AND PROPRIETARY INFORMATION. THIS INFORMATION MAY NOT BE REPRODUCED, COPIED, OR LOANED, IN PART OR IN WHOLE, NOR IS THE INFORMATION TO BE RELATED TO ANY PARTY WITHOUT CHART'S PRIOR WRITTEN CONSENT.	PART NUMBER 14190909	UNLESS OTHERWISE SPECIFIED DIMENSIONS ARE IN INCHES. TOLERANCES: FRACTIONS ± 1/8 DECIMALS ± .01 2 PLACE DECIMALS ± .005 3 PLACE DECIMALS ± .001
--	--------------------------------	--

DISTRIBUTION & STORAGE GROUP New Prague Operations	APPLICATION HS-3000 THRU 6000 SS COLD STRETCH 175/250/400PSI
DRAWING NO. C-14190909	REV SCALE 1/32"=1" DO NOT SCALE DRAWING SHEET 1 OF 1

INNER VESSEL DESIGN DATA			
MODEL:		HS-9000 THRU 15000	
MAWP:	PSIG	175	250
	barg	12.07	17.24
DESIGN PRESSURE	PSIG	213.5	288.5
	barg	14.72	19.98
CODE COMPLIANCE: ASME CODE CASE 2596			
DESIGN TEMPERATURE	°F	-320° TO 120°	
TEMPERATURE	°C	-196° TO 49°	
MATERIAL OF CONSTRUCTION: SA240 304 STAINLESS STEEL			
OUTER VESSEL DATA			
CODE COMPLIANCE: FULL VACUUM PER CGA-341			
DESIGN TEMPERATURE	°F	-20° TO 300°	
	°C	-29° TO 149°	
MATERIAL OF CONSTRUCTION: A36 CARBON STEEL			
INSULATION TYPE: VACUUM AND MULTILAYER INSULATION			
EVACUATION CONNECTION: 3-1/2" PUMPOUT PORT			
VACUUM GAUGE CONNECTION: HASTINGS DV6R			
BUILDING CODE:			
DESIGNED FOR CURRENT BUILDING CODE SEE CHART POLICY #NP-180			

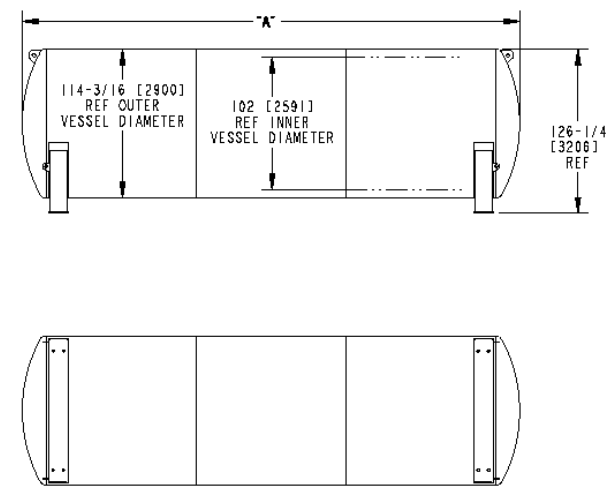
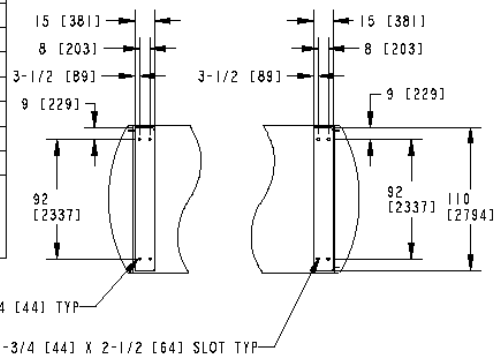

WEIGHTS AND SHIPPING DATA										
MODEL:		HS-9000		HS-1000		HS-13000		HS-15000		
MAWP	PSIG	175	250	175	250	175	250	175	250	
	barg	12.07	17.24	12.07	17.24	12.07	17.24	12.07	17.24	
WEIGHT EMPTY	POUNDS	28,700	31,600	34,500	37,800	40,600	44,400	46,900	51,300	
	KILOGRAMS	13,018	14,334	15,649	17,146	18,416	20,140	21,273	23,269	
WEIGHT FULL	OXYGEN	POUNDS	116,800	119,600	142,000	145,300	168,700	172,600	194,700	199,000
		KILOGRAMS	52,980	54,250	64,410	65,907	76,521	78,290	88,314	90,265
	NITROGEN	POUNDS	91,000	93,900	110,600	113,900	131,300	135,100	151,500	155,900
		KILOGRAMS	41,277	42,592	50,167	51,664	59,557	61,280	68,719	70,715
	ARGON	POUNDS	136,200	139,000	165,700	169,000	197,000	200,800	227,300	231,700
		KILOGRAMS	61,779	63,049	75,160	76,657	89,358	91,081	103,102	105,097
SHIPPING DIMENSIONS	INCHES (L * W * H)	348 x 118 x 127		408 x 118 x 127		467 x 118 x 127		528 x 118 x 127		
	MM'S (L * W * H)	8,840 x 2,998 x 3,226		10,364 x 2,998 x 3,226		11,862 x 2,998 x 3,226		13,412 x 2,998 x 3,226		

TANK LENGTH		
MODEL	DIM "A" REF	
HS-9000	323-5/8 [8,221]	
HS-11000	383-5/8 [9,745]	
HS-13000	442-5/8 [11,243]	
HS-15000	503-5/8 [12,793]	

SADDLE LENGTH		
MODEL	DIM "B" REF	
HS-9000	276 [7,010]	
HS-11000	336 [8,534]	
HS-13000	395 [10,033]	
HS-15000	456 [11,582]	

CAPACITIES						
MODEL:		HS-9000	HS-1000	HS-13000	HS-15000	
CAPACITY	GROSS GALLONS	9,360	11,410	13,470	15,520	
	(COLD) LITERS	35,431	43,192	50,989	58,750	
	NET GALLONS	8,990	10,960	13,060	15,060	
	(COLD) LITERS	34,031	41,488	49,437	57,008	
GASES EQUIVALENT AT 1 ATM AND 70°F / 1 ATM AND 0°C	OXYGEN	SCF	1,034,800	1,275,400	1,503,300	1,733,500
		NM3	29,302	36,115	42,569	49,087
	NITROGEN	SCF	837,100	1,031,700	1,216,100	1,402,300
		NM3	23,704	29,214	34,436	39,709
	ARGON	SCF	1,011,400	1,246,500	1,469,300	1,694,300
		NM3	28,640	35,297	41,606	47,977

REV	ECR NO	REVISION DESCRIPTION	BY	DATE	APPROVED	DATE		
					BY: JJC	10-28-08		
					BY: MMK	10-28-08	NEXT ASS'Y	USED ON
					BY: KJR	10-29-08	APPLICATION	NEXT ASS'Y FINAL ASS'Y
					BY: DML	11-5-08	QUANTITY REQ'D	
					BY: RC	10-30-08		
					BY: JK	10-30-08		
THE MATERIALS AND INFORMATION, INCLUDING THE PRINCIPLES OF DESIGN CONTAINED IN THIS PRINT, IS THE EXCLUSIVE PROPERTY OF CHART INC., AND IS CONFIDENTIAL AND PROPRIETARY INFORMATION. THIS INFORMATION MAY NOT BE REPRODUCED, COPIED, OR LOANED, IN PART OR IN WHOLE, NOR IS THE INFORMATION TO BE RELATED TO ANY PARTY WITHOUT CHART'S PRIOR WRITTEN CONSENT.					UNLESS OTHERWISE SPECIFIED DIMENSIONS ARE IN INCHES. TOLERANCES: FRACTIONS ± 1/8 ANGLES ± 2 PLACE DECIMALS ± NA 3 PLACE DECIMALS ± NA			
MAT'L SEE B.O.M. PART NUMBER 14190917					DISTRIBUTION & Storage Group New Prague Operations HS-9000 THRU 15000 SS COLD STRETCH 175/250PSI DRAWING NO. C-14190917 SCALE 1/64"=1" DO NOT SCALE DRAWING SHEET 1 OF 1			