



APPS-160 Gen 2 User Manual

Applicable Products:

PN 11914406 - APPS-160 10 to 50 PSIG operating pressure

PN 11918618 - APPS-160 40 to 85 PSIG operating pressure



Purpose:

The APPS (Adjustable Pressure Phase Separator) is used to lower the delivery pressure and saturation point of liquid nitrogen. Liquid nitrogen at high pressure will flow into the APPS, and exit at a lower pressure. The liquid nitrogen saturation pressure / temperature will also be reduced. Liquid nitrogen enters the APPS through a solenoid valve, and exits through a Chart style 1-inch vacuum insulated female bayonet. A differential pressure switch maintains the liquid level in the cylinder. The internal pressure of the cylinder is controlled by the combination of a pressure switch connected to a solenoid valve and a back-pressure regulator. If the pressure exceeds the set point of the pressure switch, the pressure switch activates a solenoid valve to rapidly vent the APPS down to the desired working pressure.

Specifications:

	PN 11914406	PN 11918618
Operating pressure	10 to 50 psig	40 to 85 psig
Height	60 inches	60 inches
Width	45 inches (20" OD cylinder)	45 inches (20" OD cylinder)
Weight (empty)	260 pounds	260 pounds
Capacity (gross)	42 gallons / 160 liters	42 gallons / 160 liters
Cryogenic fluid	Liquid nitrogen	Liquid nitrogen
Inlet connection	½" male 45° flare fitting	½" male 45° flare fitting
Outlet connection	1" female "MVE" bayonet	1" female "MVE" bayonet
Vent	½" FPT with vent pipe	½" FPT with vent pipe
MAWP vessel	150 psig per ASME Section 8, Division 1	150 psig per ASME Section 8, Division 1
Max inlet pressure	235 psig	235 psig
Maximum withdrawal rate	15 gallons per minute continuous	15 gallons per minute continuous
Power requirement	120 V AC – 60 HZ – 5 A	120 V AC – 60 HZ – 5 A

SAFETY:**⚠ WARNING! - INSTALLATION:**

The APPS-160 should be installed by a trained, knowledgeable technician. The cryogenic piping connected to the inlet and outlet must be constructed of materials suitable for cryogenic service and properly protected from possible over-pressure. The electrical connections to the control box should be completed by a trained technician, per the wiring schematic. The APPS-160 should be located on suitable, level surface and be properly fastened to prevent movement.

⚠ WARNING! - ASPHYXIATION HAZARD:

The venting nitrogen gas may displace the available oxygen in the area to the point where the atmosphere is deficient in oxygen. The cold nitrogen vent gas can collect in low areas, increasing the potential risk. When the APPS-160 is installed indoors or in any area with poor ventilation, the installation of an oxygen monitor should be considered.

⚠ WARNING! - EXTREME TEMPERATURES:

Surfaces in contact with the cryogenic liquid nitrogen or the vent gas will become extremely cold. These surfaces should not be touched.

⚠ WARNING! - EXTREME PRESSURES:

When liquid nitrogen is warmed and vaporizes into a gas, it's volume is increased by up to 700%. If trapped in an unprotected space, very high pressures can result. Any area of piping that can trap liquid nitrogen needs to be protected with properly sized relief valve that is appropriate for cryogenic service.

⚠ WARNING! - PRESSURIZED EQUIPMENT:

In normal operation, the APPS-160 and the associated piping will be pressurized. Before the pressure vessel is serviced or any plumbing components are removed, all pressure must be released.

⚠ WARNING! - ELECTRICAL EQUIPMENT:

In normal operation, the APPS-160 has wiring that is powered with 120 volt AC power. In addition, other wiring can be activated automatically without notice. Only knowledgeable technicians should access or repair the electrical wiring.

Installation:

- Remove the APPS-160 from the shipping crate. Visually inspect the APPS to assure there is no visible shipping damage.
- Move the APPS-160 to the exact installation location. Location must be flat, level and made from a suitable material such as concrete.
 - Normally the APPS is installed outdoors, on the pad, near the bulk supply vessel.
 - Mark the locations of the four foot pad holes.
 - Move the APPS and drill holes for 3/8" cement anchors (not supplied).
 - Install cement anchors.
 - Move APPS back into position and bolt down securely.
- Connect supply piping from bulk supply vessel to APPS-160 inlet (1/2" male 45° flare fitting). Optional APPS fill hose, part number 11000920 can be used for this connection.
- Connect APPS outlet (1" "MVE" female bayonet) to vacuum insulated pipe system. Refer to vacuum insulated pipe manual for the proper procedure.
- Connect 120 V AC, 60 HZ, 5 A electrical supply to APPS control box.
 - Conduit connector is located on bottom of control box.
 - Wiring should be connected to control box as follows:
 - Black (hot) wire to "H" connection on terminal block.
 - White (neutral) wire to "N" connection on terminal block.
 - Green (ground) wire to "GND BAR"
 - Assure both valve switches are in "AUTO" position.
 - Replace control box cover and attach securely.

Start up:

- Assure APPS is completely and properly installed.
- Turn APPS power switch to "ON" position.
- Open manual supply valve slightly to start flow of gas / liquid into APPS.
 - Throttle supply valve to prevent over-pressure of the APPS (opening the relief valves) due to vaporization / cool down losses during the initial fill.
 - Slowly open the supply valve as the APPS inner vessel is cooled to cryogenic temperature.
- After fill cycle ends, APPS will vent more often than normal for the first few hours.
- After the APPS is filled and stabilized, the vacuum insulated pipe system can be "started up" per the recommended process.

Operation:

- During normal operation, the APPS will function automatically.
- The liquid level switch will monitor the liquid nitrogen level. It will open and close the fill valve to maintain the liquid nitrogen level within the preset level.
- The vent regulator will release gas as required to maintain the APPS at the preset pressure.
- The pressure switch will monitor the pressure. If the pressure rises above the set point, it will open the vent valve and release gas to reduce the pressure.
 - **CAUTION!** The vent valve will open without notice. The venting gas will be cold and loud.
- To take the APPS out of service, turn the power switch to “OFF”. The APPS will still contain liquid nitrogen, therefore it will vent gas from the vent regulator and supply liquid nitrogen from the outlet until the unit is emptied.

Adjustments:

- Operating pressure
 - To change the operating pressure of the APPS-160, the set point of the vent regulator and pressure switch must be adjusted.
 - Vent regulator should be adjusted to the desired operating pressure. Pressure switch should be adjusted to open the vent valve at 2-3 psi higher than the regulator set point.
 - To adjust vent regulator, loosen lock nut and turn adjustment bolt.
 - In or clockwise will increase set point.
 - Out or counterclockwise will decrease set point.
 - Tighten lock nut after adjustment.
 - To adjust the pressure switch (see pictures on later pages):
 - Remove cover.
 - **Use caution. To monitor adjustment, power must be on and wires will be powered or “hot”.**
 - Turn large brass hex nut.
 - In or clockwise will decrease set point.
 - Out or counterclockwise will increase set point.
 - Replace cover after adjustment.
- Liquid nitrogen level
 - The liquid nitrogen level should only be changed by an experienced technician. Incorrect adjustment can result in the APPS overfilling or running empty.
 - To change the liquid nitrogen level, the liquid level switch must be adjusted.
 - Remove cover.
 - **Use caution. To monitor adjustment, power must be on and wires will be powered or “hot”.**
 - Turn brass machine screw.
 - In or clockwise will increase set point, resulting in a higher liquid nitrogen level.
 - Out or counterclockwise will decrease set point, resulting in a lower liquid nitrogen level.
 - Replace cover after adjustment.

Service:

- The APPS should only be serviced by a knowledgeable technician.
- Power should be disconnected before covers are removed from the control box, pressure switch or liquid level switch. If not, these boxes will contain “hot” wires and/or wires that will become “hot” without notice.
- Liquid nitrogen and all pressure should be released before any plumbing component is removed.
- Potential service parts are as follows:

Model	11914406 (10-50 psig)	11918618 (40-85 psig)
Vessel PRV (100 psig)	11915572	11915572
Vessel SRV (150 psig)	11915581	11915581
Inlet piping RV (235 psig)	1810062	1810062
Vent regulator	11756911	2110582
Fill or vent valve	11542577	11542577
Pressure switch	10805996	11860241
Liquid level switch	11841147	11841147
Inlet strainer	11529090	11529090
Inlet check valve	11208931	11208931

See the pictures on the following pages for the identification of components.

Parts are available from Chart Ind. at www.chartparts.com.



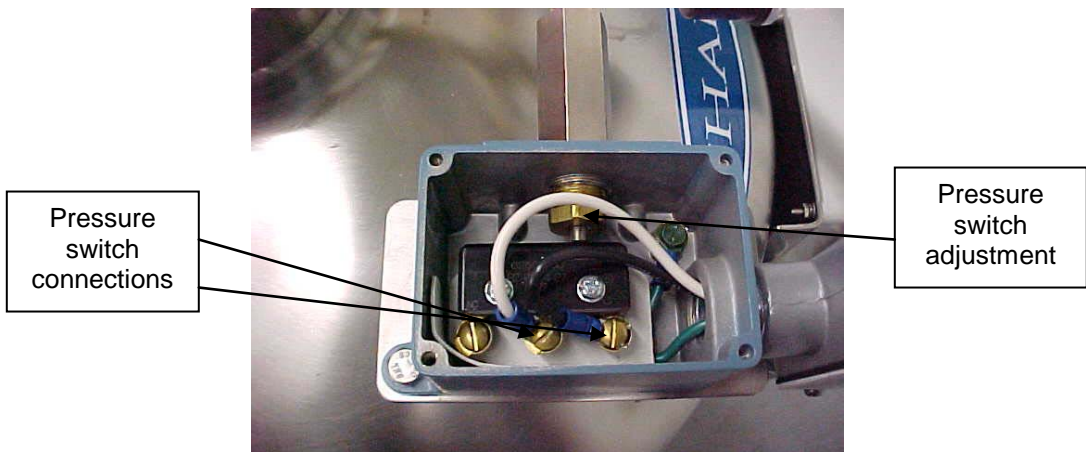
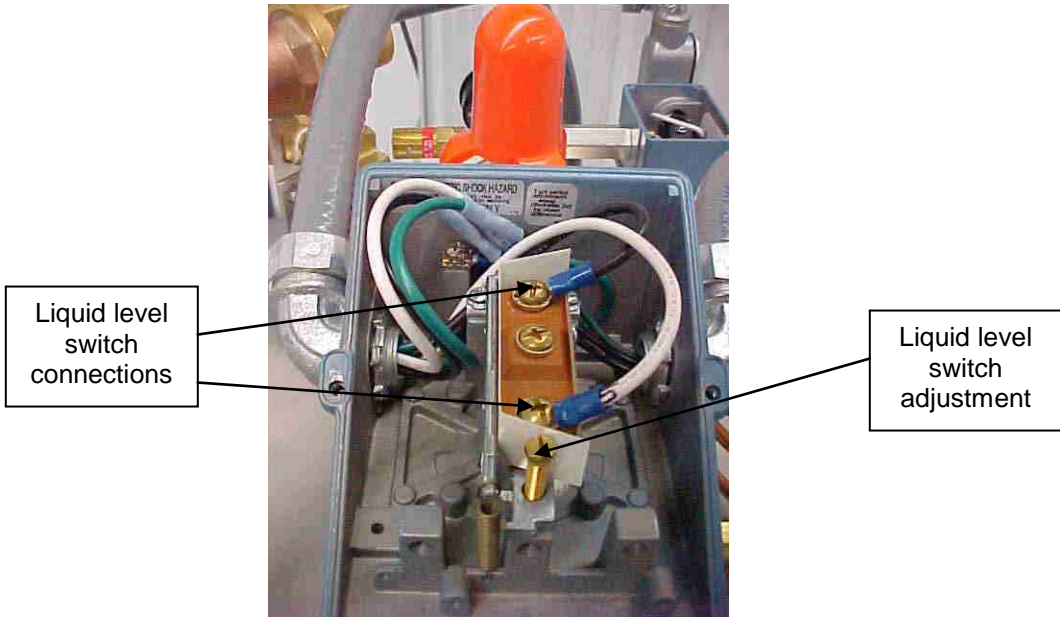
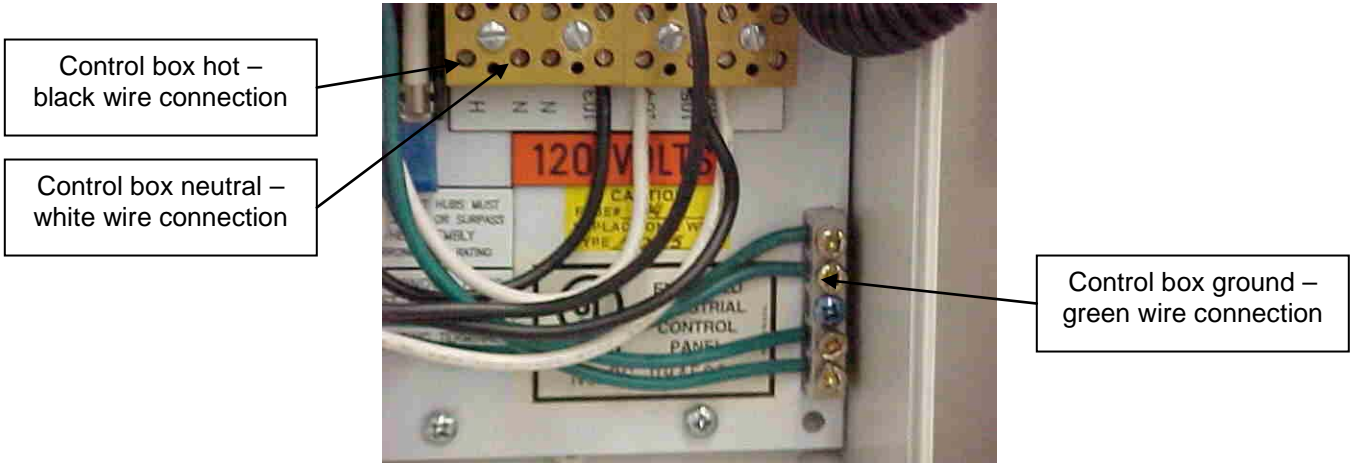

Control box electrical schematic:

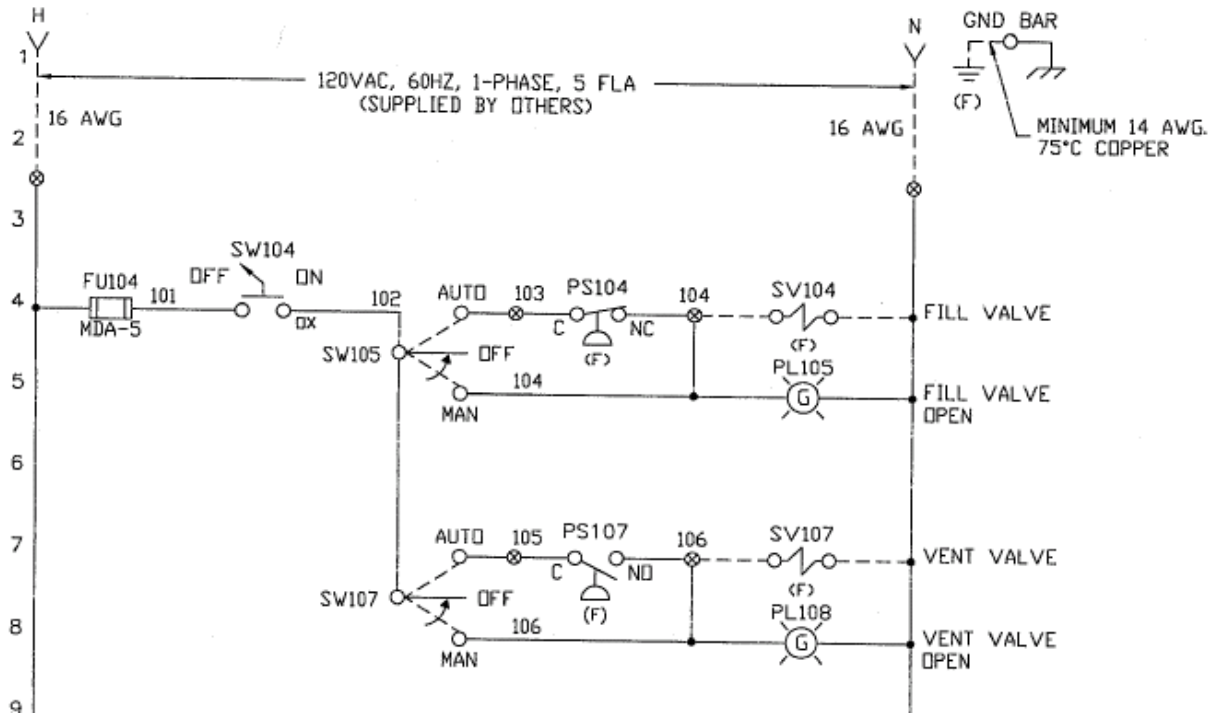

Contact information:

Chart, Industries
407 Seventh St. NW
New Prague, MN 56071

Phone – 952-758-4484

Fax – 952-758-8293

E-mail – vjpipe@chart-ind.com

Web – www.chart-ind.com