



# ***Installation Manual***

## ***Python® Vacuum Insulated Pipe***



**Designed and Built by:**

***Chart Inc.***

***407 7th Street NW  
New Prague, MN 56071 USA  
(800) 400-4683***





# Contents

---

Revision Log . . . . .	ii
<b>Preface . . . . .</b>	<b>1</b>
General . . . . .	1
Rigid Benefits . . . . .	1
Installation Manual . . . . .	1
Terms . . . . .	2
Acronyms / Abbreviations. . . . .	2
<b>Safety . . . . .</b>	<b>3</b>
Nitrogen and Argon . . . . .	3
Personal Protective Equipment (PPE). . . . .	4
<b>Instruction. . . . .</b>	<b>5</b>
Technical Information. . . . .	5
Specifications . . . . .	5
Performance Data. . . . .	5
LN <sub>2</sub> Flow Guideline . . . . .	5
Pressure Drop (psi/ft)* . . . . .	5
Receiving & Inspection . . . . .	6
Mounting Equipment . . . . .	7
Installation. . . . .	8
Sample System Installation. . . . .	8
Installation Kit . . . . .	9
Straight Joints. . . . .	10
Elbow Joints . . . . .	12
T-Joints . . . . .	15
Valve Kit . . . . .	18
Valve Kit Installation Procedure . . . . .	18
Cryovent Kit . . . . .	19
Cryovent Kit Installation Procedure . . . . .	19
Relief Valve Kit. . . . .	20
Relief Valve Kit Installation Procedure. . . . .	20
Trap Kit. . . . .	21
Trap Installation Procedure. . . . .	21
Nipple Toe. . . . .	22

## Revision Log

Revision Level	Date	Description
B	07/14/2014	Convert to new layout
C	11/13/2014	Add Preface section; replace flex photo in General Instructions section
D	03/27/2017	Remove MVIP wording throughout manual



## Preface

---

### General

Python® Vacuum Insulated Pipe products provide thermal performance that far exceed conventional foam insulation materials, take only a fraction as much space, and require no additional protection against moisture or vapors. Python piping is adaptable, reusable and easy to install. Available in 1/2" outer diameter tube (ODT), 1", 2" and 3" nominal pipe sizes (NPS).

Installed costs are comparable to most conventional mechanical insulation systems. Typical delivery on small projects is next day from stock. Installation service can be provided from one of our many locations worldwide.

Python piping is designed for temperatures down to -350°F and pressures up to 500 psi. Python systems can be modified and adapted to many applications such as liquid nitrogen, liquid argon, liquefied natural gas (LNG) and liquid carbon dioxide. Python piping is ideal for highly temperature-sensitive piping systems found in the petrochemical, energy, manufacturing, and food and beverage industries around the world.

### Rigid Benefits

- Python rigid vacuum insulated pipe is durable, easy to install and practically maintenance free
- Excellent flow characteristics make Python rigid pipe ideal for pipe mains
- Python rigid pipe can mate to Python flex's bendable pipe for inside drops
- Multi-layer superinsulation and chemical gettering assures long term vacuum integrity
- Fabricated by an ASME B31.3 code shop by certified welders (TIG welded)
- Rigid sections are less expensive, have better heat leak and less pressure drop than flexible vacuum insulated pipe
- Rigid sections will not dip between hangers and will minimize gas traps
- Rigid sections have a long life and have been known to last as long as 30 years

### Installation Manual

This manual is intended for use by Chart Python vacuum insulated pipe customers. It is important to read and understand the information in this manual before installing or operating the pipe system. This manual is provided by Chart to its customers as a courtesy and, except as expressly provided in this manual, Chart makes no warranties, express or implied, regarding the contents in this manual.

Any information contained in other manuals for equipment supplied by third party manufactures (including, but not limited to valves, actuators, relief valves, etc.) shall take precedence over information contained within this manual with respect to that third party equipment.

## Terms

Throughout this manual safety precautions will be designated as follows:



**Warning!** *Description of a condition that can result in personal injury or death.*



**Caution!** *Description of a condition that can result in equipment or component damage.*



**Note:** *A statement that contains information that is important enough to emphasize or repeat.*

## Acronyms / Abbreviations

The following acronyms / abbreviations are used throughout this manual:

ASME	American Society of Mechanical Eng.
BTU	British Thermal Unit
GPM	Gallons per Minute
KG	Kilogram
kJ	Kilojoule
LN <sub>2</sub>	Liquid Nitrogen
LNG	Liquefied Natural Gas
LPM	Liters per Minute
MLI	Multi-Layer Insulation
NPS	Nominal Pipe Size
OAL	Overall Length
ODT	Outer Diameter Tube
PN	Part Number
PSI	Pounds per Square Inch
PSIG	Pounds per Square Inch (Gauge)

## Safety

Python® Vacuum Insulated Pipe is intended to be used with pressurized, ultra-cold cryogenic liquids and gases. Only properly trained personnel should handle, install and/or operate this pipe system. Please review the Safety section in the VIP Product Manual (PN 14736238 available on [www.chartparts.com](http://www.chartparts.com)) along with the Warnings stated here. If there are any questions about the proper handling or use of this equipment, stop immediately and contact the factory for proper methods.



**Warning! EXTREME TEMPERATURES AND PRESSURES:** This equipment uses extreme temperatures and pressurized fluids. Failure to follow instructions and use proper safety precautions can cause severe injury or death.



**Warning! ASPHYXIATION HAZARD:** This equipment uses cryogenic fluids / gases that can displace oxygen and cause severe injury or death due to lack of oxygen. ALWAYS ensure proper ventilation of environment to maintain proper oxygen levels. Chart always recommends the use of an oxygen monitor where the risk of reduced oxygen levels exist.



**Warning! RAPID PRESSURE RISE HAZARD:** Any time a cryogenic liquid or cold gas is trapped between any two valves, rapid pressure rise can occur. It is extremely important that a pressure relief valve is installed in any such point in the system where liquid / cold gas can become trapped. Severe injury or death can occur due to failure to comply with this warning.



**Warning! DO NOT USE Python piping for oxygen or hydrogen service.** Python pipe is NOT compatible with oxygen or hydrogen.

Python vacuum insulated pipe is rated to 400 psig pressure. Pressures above this should not be used.

External valves and fittings can become extremely cold and may cause painful burns to personnel unless properly protected. Personnel must wear protective gloves and eye protection whenever removing parts or loosening fittings. Failure to do so may result in personal injury due to the extreme cold and pressure in the system.



**Warning! Accidental contact of liquid gases with skin or eyes may cause a freezing injury similar to a burn.**

## Nitrogen and Argon



**Warning! Nitrogen and argon vapors in air may dilute the concentration of oxygen necessary to support or sustain life.**

Nitrogen and argon (inert gases) are simple asphyxiates. Neither gas will support or sustain life and can produce immediate hazardous conditions through the displacement of oxygen. Under high pressure these gases may produce narcosis even though an adequate oxygen supply sufficient for life is present.

Nitrogen and argon vapors in air dilute the concentration of oxygen necessary to support or sustain life. Inhalation of high concentrations of these gases can cause anoxia, resulting in dizziness, nausea, vomiting, or unconsciousness and possibly death. Individuals should be prohibited from entering areas where the oxygen content is below 19% unless equipped with a self-contained breathing apparatus. Unconsciousness and death may occur with virtually no warning if the oxygen concentration is below approximately 8%. Contact with cold nitrogen or argon gas or liquid can cause cryogenic (extreme low temperature) burns and freeze body tissue.

Persons suffering from lack of oxygen should be immediately moved to areas with normal atmospheres. SELF-CONTAINED BREATHING APPARATUS MAY BE REQUIRED TO PREVENT ASPHYXIATION OF RESCUE WORKERS. Assisted respiration and supplemental oxygen should be given if the victim is not breathing. If cryogenic liquid or cold boil-off gas contacts worker's skin or eyes, the affected tissue should be flooded or soaked with tepid water (105-115°F or 41-46°C). DO NOT USE HOT WATER. Cryogenic burns that result in blistering or deeper tissue freezing should be examined promptly by a physician.

## ***Personal Protective Equipment (PPE)***

The following personal protective equipment is recommended when working around cryogenic liquid:

- Safety glasses with side shields to prevent cryogenic liquid from splashing into the eyes
- Chemical / Liquid resistant gloves to prevent cryogenic burns on exposed hands
- Long sleeve shirts to protect the arms
- Cuffless trousers worn over closed shoes





# Instruction

## Technical Information

### Specifications

Smart Number	Inner Pipe Size	Nominal Outside Jacket Diameter*	Actual Flow Diameter	Standard Overall Lengths**	Hole Required to Accommodate Pump Out	Outer Diameter with Braid	Weight / Length	MAWP (psi)
PY-08-PR	1/2" ODT	1-1/4" NPS	0.430"	2' - 20' in 1' increments, and 6' 6" length	2-1/2"	1-13/16"	1.5 lb/ft	500
PY-16-PR	1" NPS	2" NPS	1.185"		4"	2-9/16"	3.0 lb/ft	400
PY-32-PR	2" NPS	3" NPS	2.245"		5"	5"	5.0 lb/ft	400
PY-48-PR	3" NPS	5" NPS	3.334"		7"	7-1/8"	11.0 lb/ft	400

\*Not including pump out

\*\*Flex section lengths: 1/2"-6', 1"-8', 2"-9', 3"-9'

### Performance Data

Smart Number	Vacuum Insulated Pipe					Insulation Kits					
	Cool Down			Static Heat Leak		Straight		Elbow		Tee	
	kJ/m	kg/m*	lb of LN <sub>2</sub> /ft	BTU/hr/ft	Watt/m	BTU/hr	Watt	BTU/hr	Watt	BTU/hr	Watt
PY-08-PR	12	0.06	0.04	0.32	0.41	13	3.8	25	7.3	25	7.3
PY-16-PR	58	0.29	0.19	0.48	0.46	13	3.8	25	7.3	25	7.3
PY-32-PR	107	0.54	0.36	0.79	0.76	25	7.3	50	14.6	50	14.6
PY-48-PR	203	1.02	0.68	1.08	1.04	35	10.2	65	19.0	65	19.0

\*LN<sub>2</sub> at one bar

### LN<sub>2</sub> Flow Guideline

Smart Number	Maximum Recommended Flow Rate*		
	gpm	lpm	kg/hr
PY-08-PR	1.5	5.7	274
PY-16-PR	18	68.1	3283
PY-32-PR	95	360	17328
PY-48-PR	255	965	46512

\*Flow rate values are for a system with: 100' of pipe, 3 elbows, and 2 tees. Chart recommends pressure drop be kept to 5 psi or less.

### Pressure Drop (psi/ft)\*

Smart Number	Flow (gal/min)							
	2	5	10	25	50	75	100	150
PY-08-PR	0.080	0.501						
PY-16-PR		0.003	0.011	0.063	0.262	0.570	1.014	
PY-32-PR				0.002	0.009	0.193	0.034	0.077
PY-48-PR					0.001	0.003	0.005	0.011

\*Pressure drop numbers listed do not account for elevation changes. Chart recommends pressure drop be kept to 5 psi or less.

## Receiving & Inspection

1. Inspect all pipes to ensure no shipping damage has occurred. If any section of pipe is damaged or missing contact the shipping carrier and Chart immediately.
2. Set up clamps, hangers, and/or rollers to the designed layout. Listed below are the recommended maximum support spans.

Inner Pipe	Jacket Outer Diameter	Weight w/o Joint Kits	Recommended Support Span	Max. Pipe Support Span
1" NPS	2.375"	2.5 lbs/ft	10 feet	12 feet
2" NPS	3.500"	4.7 lbs/ft	10 feet	12 feet
3" NPS	5.563"	9.6 lbs/ft	8 feet	10 feet

3. Place pipe in or onto the clamps, hangers and/or rollers. Commonly used setups are pictured under the mounting section in this manual. These support styles are just examples and other styles can be used, but be sure that the mounting style allows for the contraction and expansion of the pipe. With liquid nitrogen running through the system, the pipe can contract as much as 3.3" in every 100' of pipe.
4. Pressure relief valves should be installed in any sections where liquid can be trapped. When the process fluid is a cryogen, relief valves must be installed on a riser 10" - 12" long so that it remains warm. Relief valves must be positioned or vented in a safe manner away from personnel, equipment, and/or other safety concerns. Relief valves located outside should be designed to prohibit moisture from resting on the seat or discharge surface.
5. Once all pipe sections are in place refer to the pages in this manual that involve the necessary joint installations for your system. Care should be taken to allow space for the insulation joints. The following tables give dimensions of the joint kits.

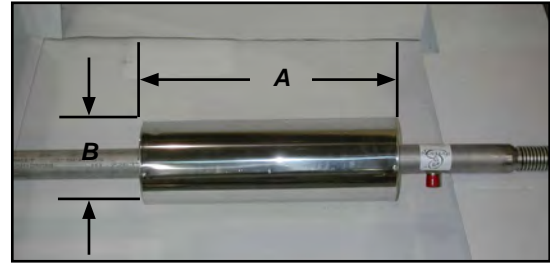

Straight Joint Kit		
Python Pipe Size	'A' Dimension	'B' Dimension
1"	19-1/2" (49.5 cm)	6-3/4" (11.1 cm)
2"	25-3/8" (64.5 cm)	8" (20.3 cm)
3"	25" (63.5 cm)	9-1/2" (24.1 cm)

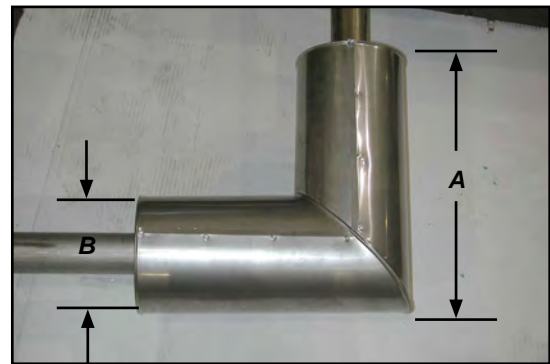

Elbow Joint Kit		
Python Pipe Size	'A' Dimension	'B' Dimension
1"	15-1/2" (39.4 cm)	6-3/4" (11.1 cm)
2"	23-1/4" (59.0 cm)	8" (20.3 cm)
3"	24" (61.0 cm)	9-1/2" (24.1 cm)

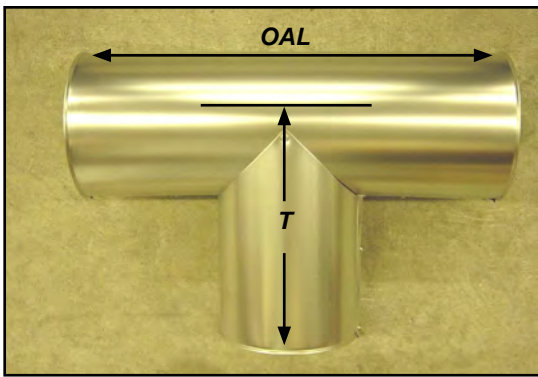

Tee Joint Kit			
Python Pipe Size	OAL	Diameter	T
1"	19-1/2" (49.5 cm)	6-3/4" (11.1 cm)	10" (25.4 cm)
2"	24-1/4" (61.6 cm)	8" (20.3 cm)	12-1/4" (31.1 cm)
3"	25" (63.5 cm)	9-1/2" (24.1 cm)	12-1/2" (31.8 cm)

6. Custom flex expansion / contraction transition joints should not exceed the recommended bend radius. The following table gives dimensions of the flex transition joints.

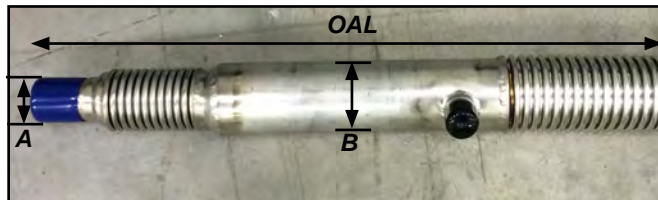

Python Pipe Size	Outer Pipe 'A' Diameter	Outer Flex 'B' Diameter	OAL	Minimum Recommended Bend Radius
1"	1.315"	2.60"	8' - 6"	12 inches
2"	2.375"	5.00"	9' - 0"	20 inches
3"	3.500"	5.00"	9' - 0"	20 inches

## Mounting Equipment

The photo below shows one type of clamp that can be used to support / mount the pipe. This type of clamp provides the pipe with a snug fit that also allows it to expand and contract along its axis.

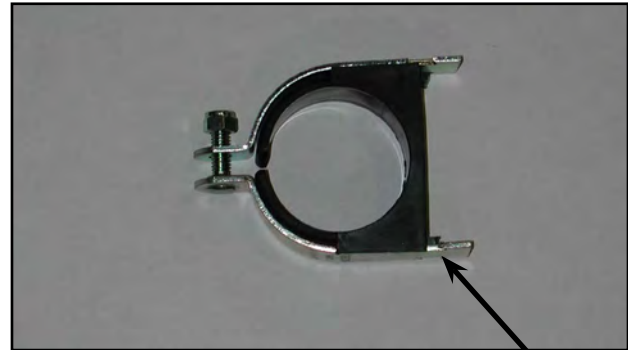

Overlapping metal pieces

- To install this clamp a strut is needed (see photo below). The overlapping metal pieces on the clamp slide into the strut (see photo below). The pipe then slides into the clamp.

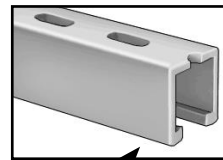

Strut



J-style hangers are another type of support that can be used. Attach the J-hanger to a ceiling support and then remove the bolt and place pipe onto the hanger. Tighten the nut until pipe is being supported. Do not over tighten which would prohibit the pipe from expanding and contracting.



## Installation

### Sample System Installation

#### Sample System #1: No Flex Section

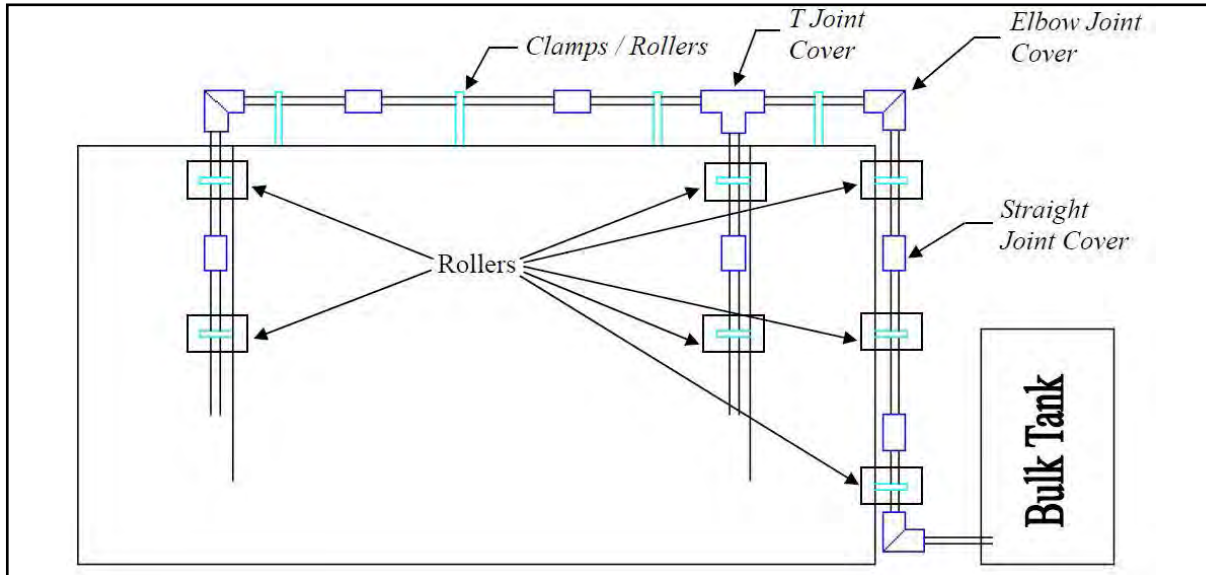

- In this sample system rollers must be used on vertical pipe because the cryogenic temperatures will cause the pipe to contract. If rollers are not used pipe will be damaged.

#### Sample System #2: Flex Section at Elbow

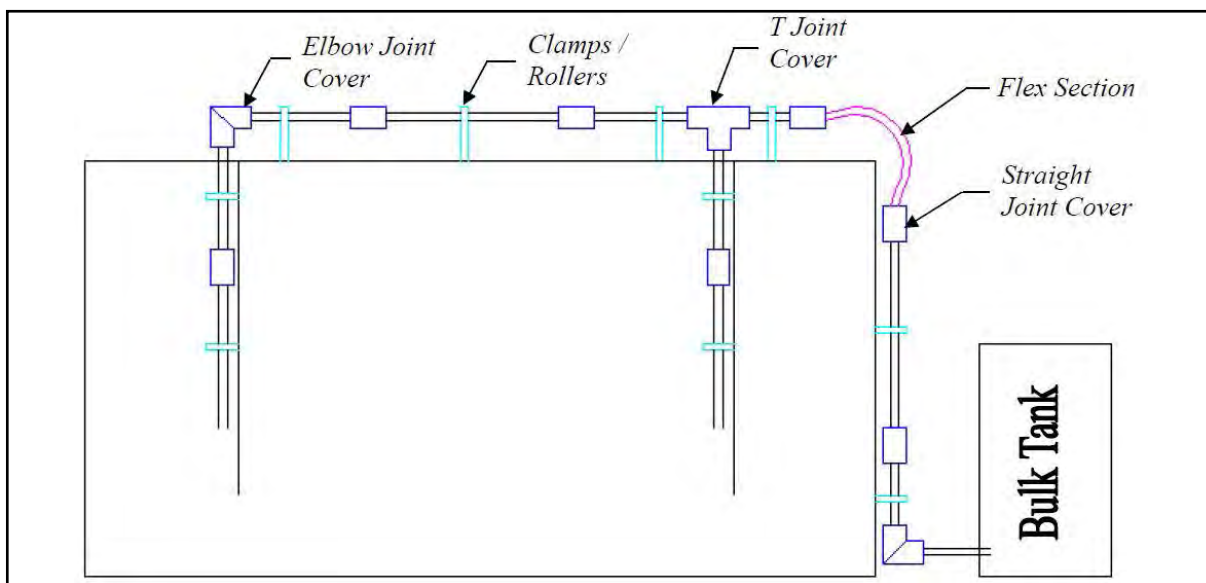

- In this sample system a flex section is used to make the elbow connection. This works well because if installed correctly, the flex section allows the expansion and contraction of the pipe caused by cryogenic temperatures.
- Clamps or rollers can be used on the roof. If using clamps do not over tighten because the pipe system will still move in the axial direction. If clamps are over tightened damage could occur to the pipe.

**Sample System #3: Flex Section at Straight**

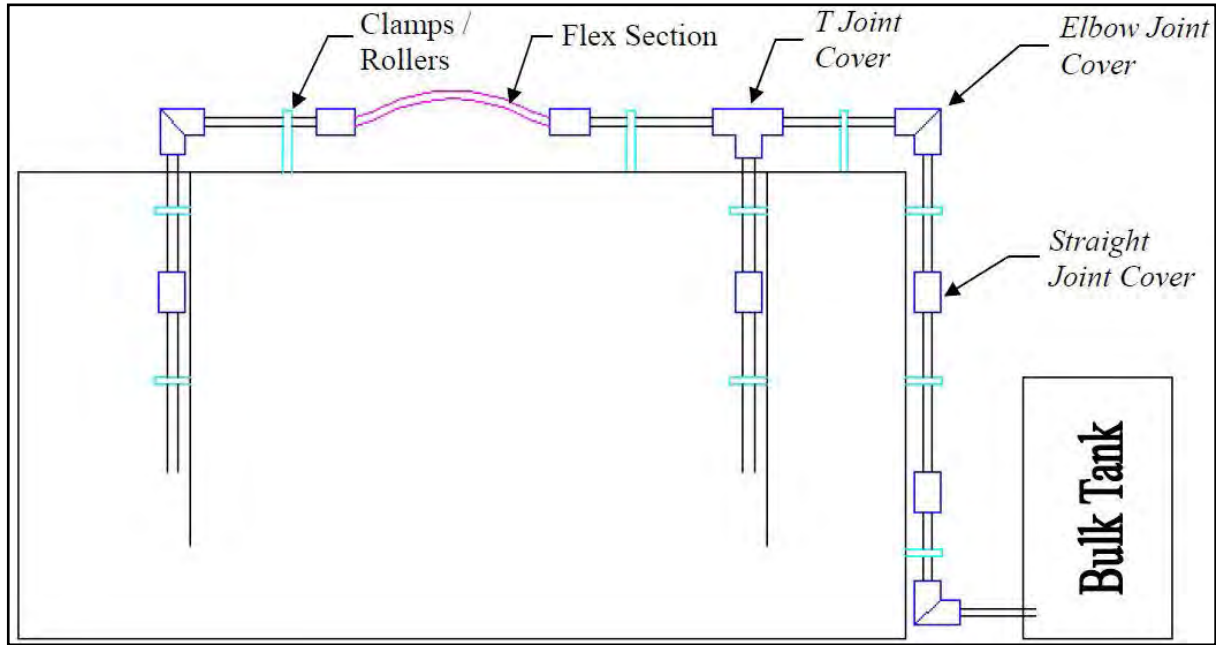

- In this sample system a flex section is used but not at the corner. This is also a good option as the flex section allows the pipe to expand and contract.
- The flex section must be installed so that the pipes have enough room to expand and contract. In order to allow for this expansion / contraction, bow the flex section out (in any direction) so that there is room for the pipe to move.
- Clamps or rollers can be used on roof. If using clamps do not over tighten because pipe system will still move in the axial direction. If clamps are over tightened damage to pipe could occur.

**Installation Kit**

PN 11002861 includes:

- 4 Boxes of Rubatex Foam Insulation Tape
- 2 Tubes of RTV Silicone Sealer
- 1 Roll Aluminum Foil Tape

If any part is missing, wrong or damaged please contact Chart as soon as possible.

The table below shows how many pipe joints can be completed with each kit based on the pipe diameter.

Pipe Diameter	Number of Joints Completed
1"	8 Joints per kit
2"	6 Joints per kit
3"	4 Joints per kit

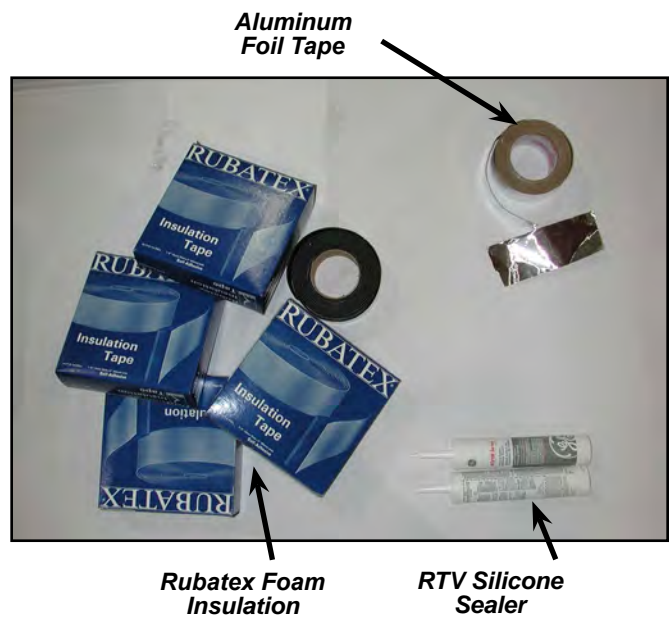

## Straight Joints

### Straight Joint Kit

1" - PN 11019209

2" - PN 11050530

3" - PN 11824831

Included in the kit:

- Stainless Steel Straight Joint Cover
- Multi-Layer Insulation (MLI) 40 inches



If any part is missing, wrong or damaged please contact Chart as soon as possible.

### Straight Pipe Sections

When installing a straight joint kit refer to this photo for sections A and B of the pipe.

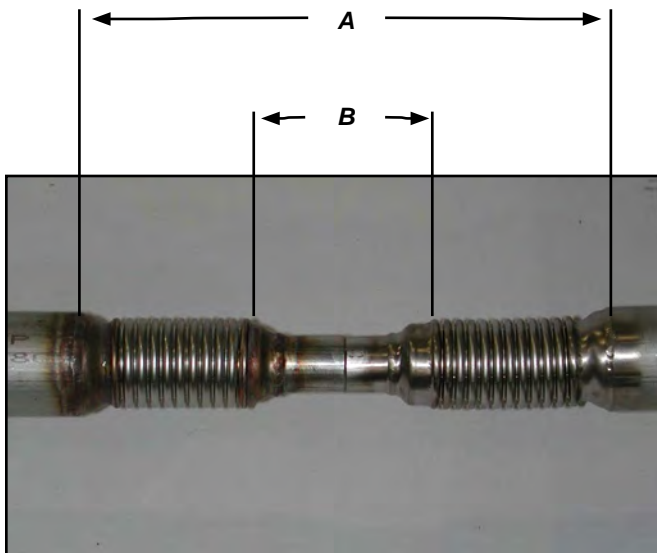

### Straight Joint Installation Procedure



**Caution!** *Stainless steel edges of joint cover and aluminum foil tape are extremely sharp; use caution when handling.*



**Warning!** *Excess heat may cause vacuum loss in pipe.*



1. Measure and mark pipe to be certain joint insulation cover is centered about the joint.



2. Slide stainless steel joint cover and foam on either pipe section.



3. TIG weld the two ends together.



**Warning!** *Excess heat may cause vacuum loss in pipe.*

4. After welding, a bubble test should be completed to determine if the weld was successful. If unsuccessful, the joint must be re-worked. If no bubbles are present move on to step 5.



5. Wrap MLI (supplied in kit shown on page 10) over section B of pipe. All 40 inches should be applied. Do not exceed diameter of bellows (section A). Use a small piece of aluminum foil tape to keep it from unwrapping.
- Optional after MLI - One layer of aluminum foil tape can be wrapped over section A to aid in the removal of foam insulation (applied in next step) if it is not applied correctly.



6. Wrap foam insulation over section A. Do not wrap too tightly because insulation will not be as effective. Also do not exceed outer diameter of pipe. If outer diameter of pipe is exceeded, disassembly of the steel joint cover is required.



7. Wrap a layer of aluminum foil tape over section A over the foam insulation.



8. Slide steel joint cover and foam over the joint. If cover does not slide over insulation wrap disassembly of the steel joint kit is required.
- a. Disassembly and reassembly of the straight steel joint kit involves:
- Taking screws out
  - Taking ends off
  - Slipping the joint kit over the insulation
  - Putting ends back on
  - Putting screws back into same holes



9. Slide or place cover over aluminum tape and insulation to the marks on pipe (made in step 1) or until cover is centered over joint.



10. Caulk all edges with silicone sealer. (Sides and seams where metal cover overlaps itself.)



11. Completed joint installation should look like this.

## Elbow Joints

### Elbow Joint Kit

- 1" - PN 11021430
- 2" - PN 11050521
- 3" - PN 11824849

Included in the kit:

- Stainless Steel Elbow Joint Cover
- Elbow Joint Connector
- Multi-Layer Insulation (MLI) 40 inches



If any part is missing, wrong or damaged please contact Chart as soon as possible.

\* Remove three screws to slide up cover on each leg before welding.



### Elbow Pipe Sections

When installing an elbow joint kit refer to this photo for sections A and B of pipe.

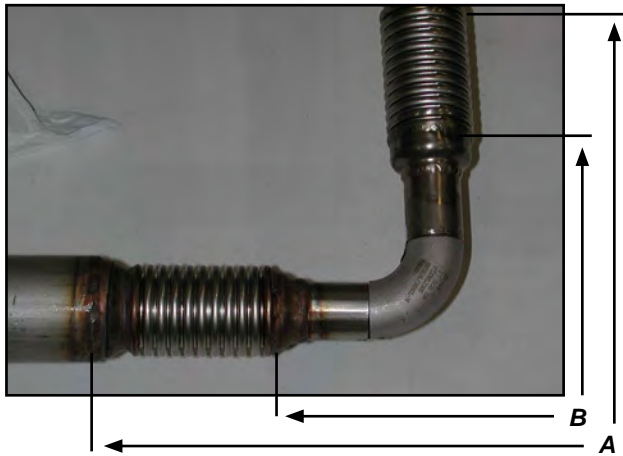

3. Wrap MLI (supplied in kit) over section B of pipe. All 40 inches should be applied. Do not exceed diameter of bellows (section A). Use a small piece of aluminum foil tape to keep it from unwrapping.
  - Optional after MLI - one layer of aluminum foil tape can be wrapped over section A to aid in the removal of foam insulation (applied in next step) if it is not applied correctly.

### Elbow Joint Installation Procedure



**Caution!** *Stainless steel edges and aluminum foil tape are extremely sharp; use caution when installing.*



**Warning!** *Excess heat may cause vacuum loss in pipe.*

1. TIG weld pipe ends together using supplied elbow connector (see heat warning above). Make sure elbow is 90° or insulation kit will be difficult to install.



4. Wrap foam insulation over section A. Do not wrap too tightly because insulation will not be as effective. Also do not exceed outer diameter of pipe. If outer diameter of pipe is exceeded, disassembly of steel joint cover is required.
  - a. Disassemble steel elbow joint cover:
    - Take screws out
    - Take ends off

2. After welding, a bubble test should be completed to determine if the weld was successful. If unsuccessful, the joint must be re-worked. If no bubbles are present move on to step 3.

5. Wrap a layer of aluminum foil tape over section A over the foam insulation.



6. Put one side of insulation in place. Then use tape to hold the foam together. This will make it easier to slide metal covers into place.

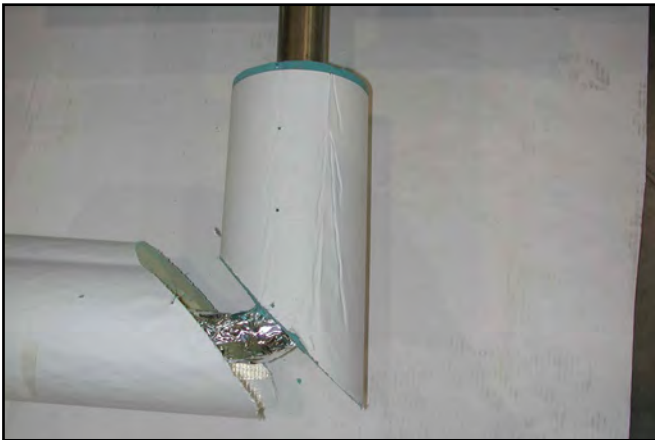

7. Put other section of insulation on and tape foam together.

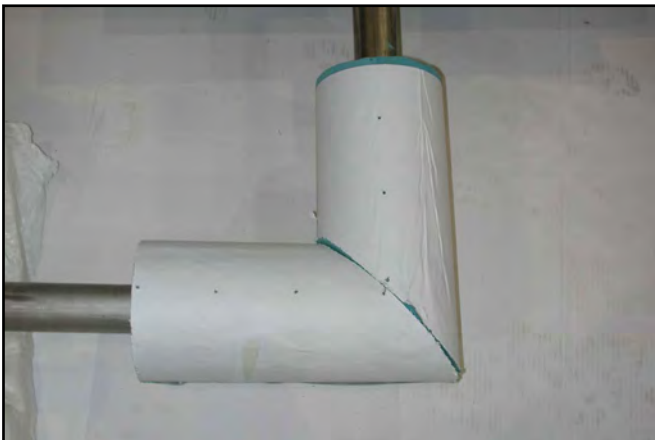

8. Slide steel cover and ends into place.

- Pay attention to which cover needs to go on first. Directly at the elbow one cover overlaps the other cover. The section that does not overlap is going to be called the first cover section.

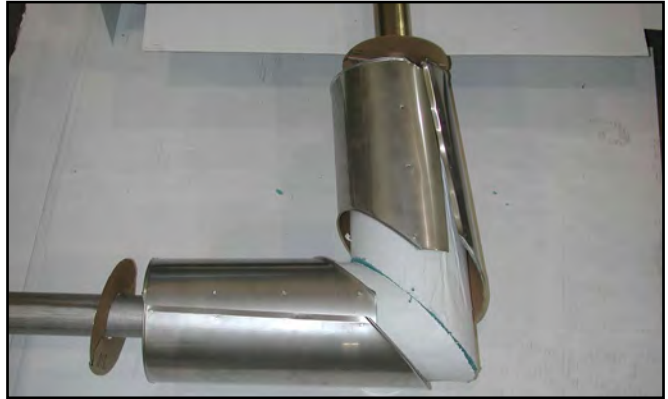

9. Put the first cover section in place.

- Put the end on
- Line up the holes
- Screw together

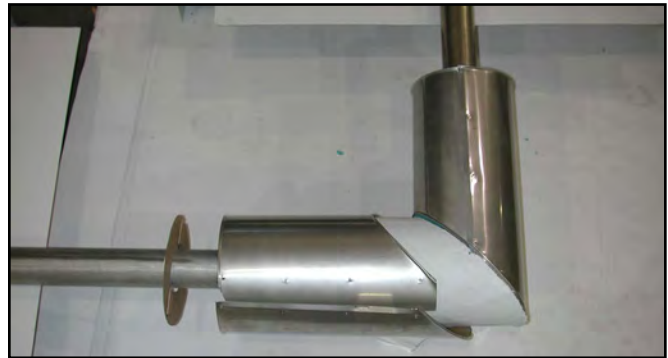

10. Put the other cover into place. Make sure that the metal edge goes over the first cover section.

- Put the end on
- Line up the holes
- Screw together



11. Caulk all edges, including the seams where the metal overlaps.



12. Completed elbow joint after installation should look like this.

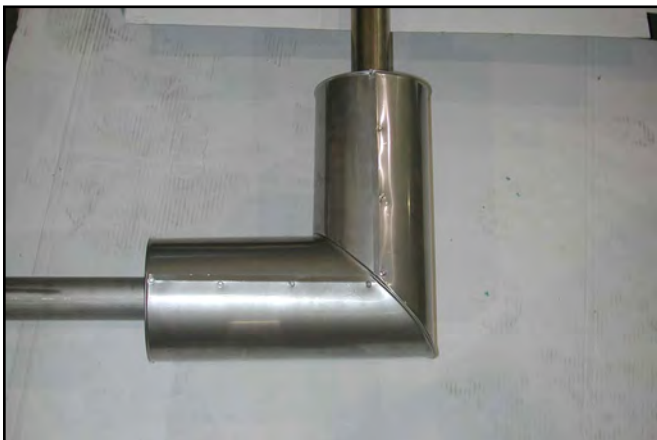

### T-Joints

#### T-Joint Kit

- 1" - PN 11018855
- 2" - PN 11050548
- 3" - PN 11824857

Included in the kit:

- Stainless Steel T-Joint Cover
- T-Joint Connector
- Multi-Layer Insulation (MLI) 40 inches

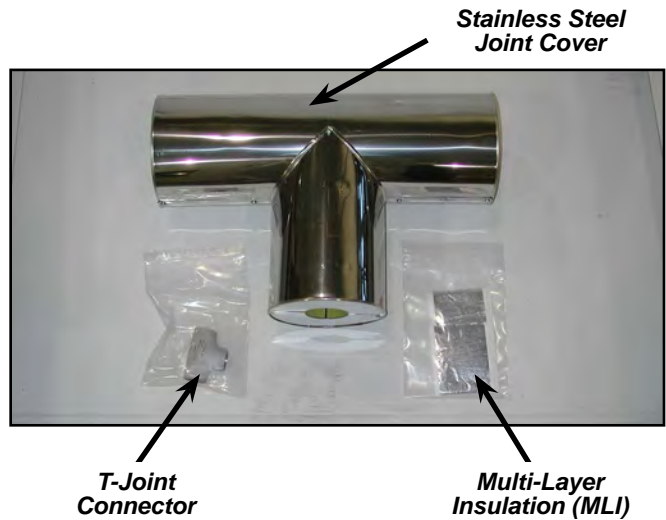

If any part is missing, wrong or damaged please contact Chart as soon as possible.

### T-Pipe Sections

When installing a T-joint kit refer to this photo for sections A and B of the pipe.

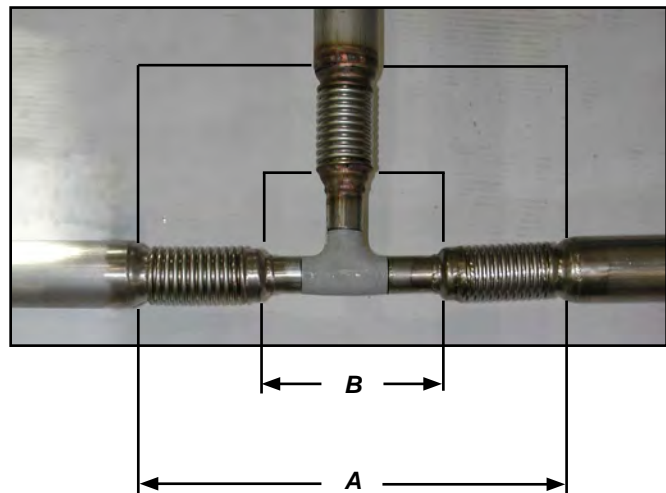

### T-Joint Installation Procedure



**Caution!** *Stainless steel edges and aluminum foil tape are extremely sharp; use caution when installing.*



**Warning!** *Excess heat may cause vacuum loss in pipe.*

- Using provided T-Joint Connector, TIG weld pipes together (see heat warning above). Make sure angles are 90° or insulation kit will be difficult to install.

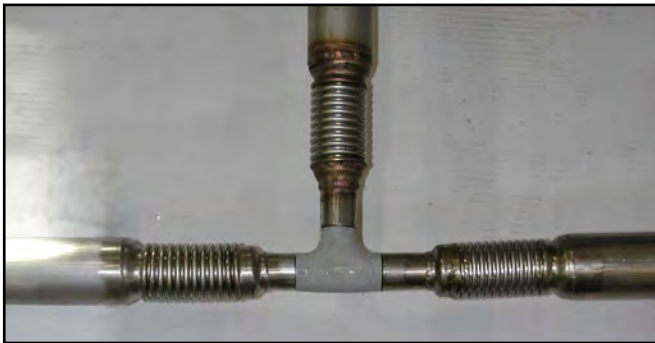

\* Remove two screws to slide branch leg onto pipe before welding.

- After welding, a bubble test should be completed to determine if the weld was successful. If unsuccessful, the joint must be re-worked. If no bubbles are present move on to step 3.

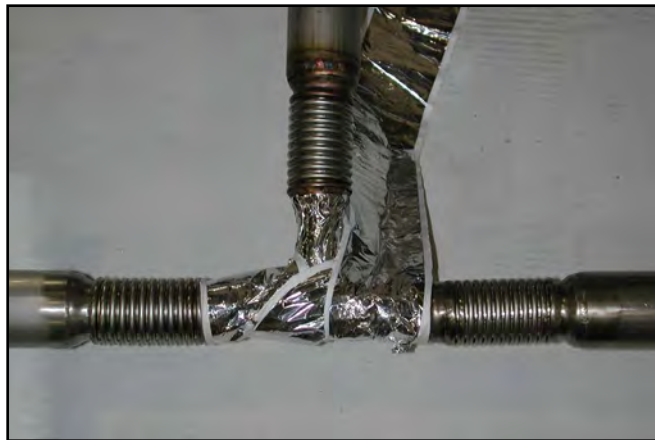

- Wrap MLI (supplied in kit) over section B of pipe. All 40 inches should be applied. Do not exceed diameter of bellows (section A). Use a small piece of aluminum foil tape to keep it from unwrapping.
  - Optional after MLI - one layer of aluminum foil tape can be wrapped over section A to aid in the removal of foam insulation (applied in next step) if it is not applied correctly.

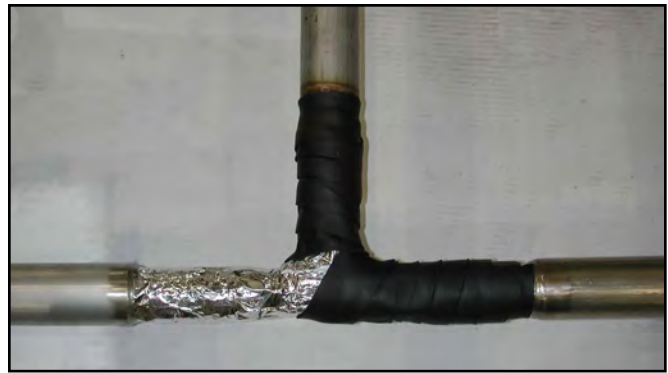

- Wrap foam insulation over section A. Do not wrap too tightly because insulation will not be as effective. Also do not exceed outer diameter of pipe. If outer diameter of pipe is exceeded, disassembly of steel joint cover is required.



- Completed foam insulation should look like this.



- Wrap a layer of aluminum foil tape over the foam insulation on section A.

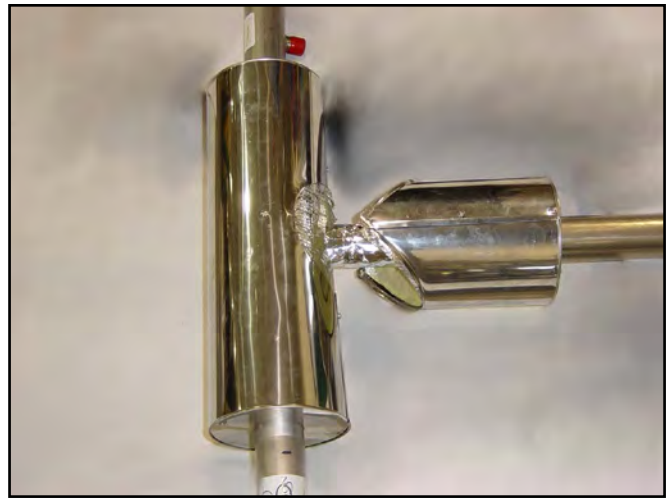

7. Take steel T-joint insulation cover apart.
- Take screws out
  - Take ends off
- Put small section of T-joint (metal cover and insulation) onto pipe by slipping it around the pipe. Put long T-joint ends on also, as seen in picture above.

9. Attach longer T-joint cover and insulation.
- Put ends in place
  - Line up holes
  - Put screws in



8. Put longer T-joint section (metal cover and insulation) over aluminum foil tape by sliding it around pipe.

10. Slide small T-joint cover over aluminum tape and attach it to longer T-joint cover.
- Put end on
  - Line up holes
  - Put screws in

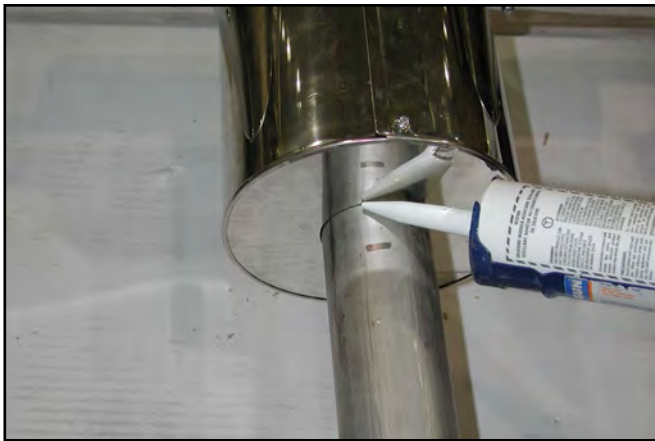

11. Caulk all edges, including seams where metal meets.



12. After completion, T-joint should look like this.

### Valve Kit

- 1" - PN 11749789
- 2" - PN 11749797
- 3" - PN 11826158

Included in the kit:

- 2 - Stainless Steel Nipple Toes
- Brass Globe Valve
- Stainless Steel Straight Joint Cover
- 2 - Multi-Layer Insulation (MLI) 40 inches

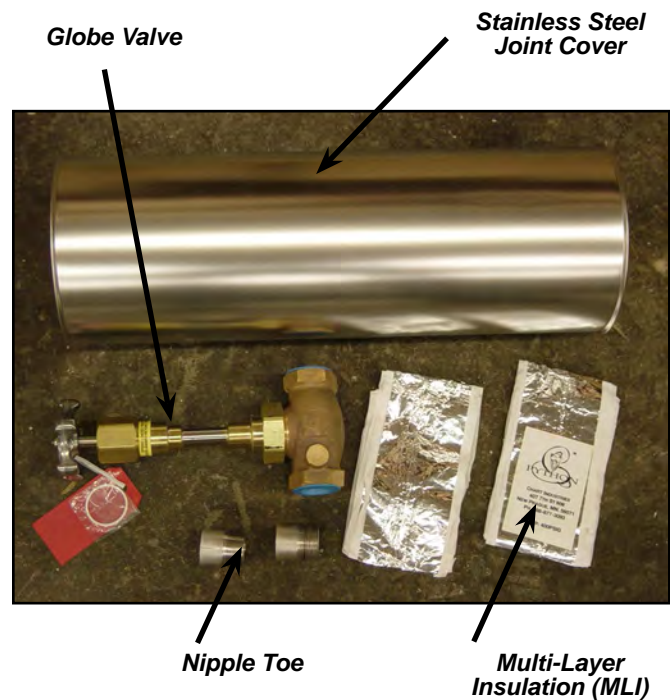

If any part is missing, wrong or damaged please contact Chart as soon as possible.

### Valve Kit Installation Procedure

1. Python vacuum insulated pipes are welded to the supplied nipple toes, while following the procedure outlined on page 10 "Straight Joints" and "Straight Joint Installation Procedure."

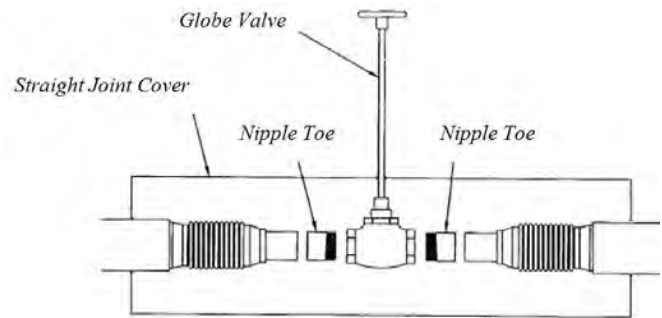

2. After welding, a bubble test should be completed to determine if the weld was successful. If unsuccessful, the joint must be re-worked.
3. Use Teflon tape to seal all threaded joints.
4. Assemble by threading the two welded nipple toes to the globe valve.
5. Apply super-insulation to unjacketed areas.
6. Apply foam insulation tape (from installation kit) to fill voids between the assembly and the foam insulation in the cover.

- Install straight joint cover. There may be excess insulation tape or foam insulation that needs to be trimmed back. The inside foam of the straight joint cover will also need to be trimmed to allow the globe valve and nipple toes to fit accordingly.

### Cryovent Kit

- 1" - PN 11749762
- 2" - PN 11749771
- 3" - PN 11826174

Included in the kit:

- 2 - Brass Nipple Hex
- Stainless Steel Reducer
- Stainless Steel T-Joint Cover
- T-Joint Connector
- 2 - Multi-Layer Insulation (MLI) 40 inches
- Stainless Steel Nipple Toe
- Brass Street Elbow
- Float Assembly
- Brass Globe Valve
- Brass Check Valve
- Brass Connector

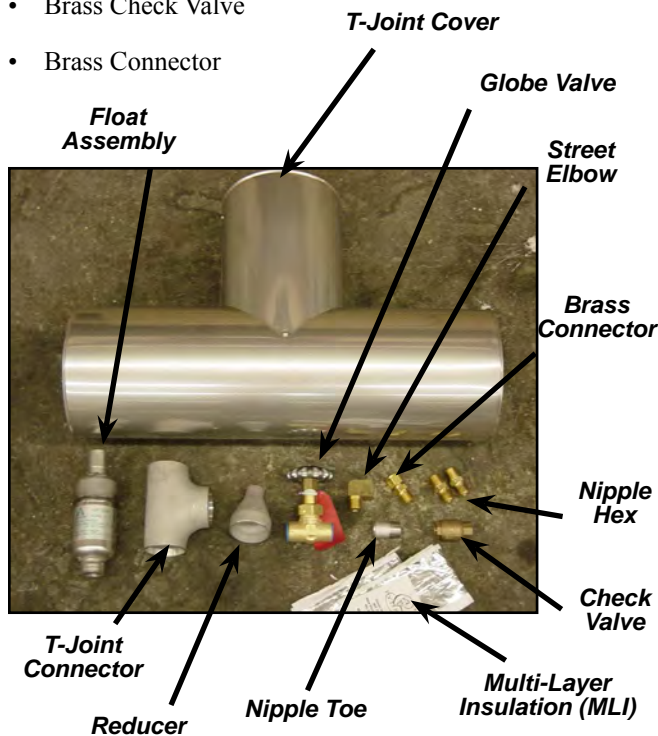

If any part is missing, wrong or damaged please contact Chart as soon as possible.

### Cryovent Kit Installation Procedure



**Warning!** In LN<sub>2</sub> service, the Cryovent will leak if used at pressures above 150 psig.

- Python pipes are welded using the supplied tee, while following the procedure outlined on page 15 & 16 "T-Pipe Sections" and "T-Joint Installation Procedure."

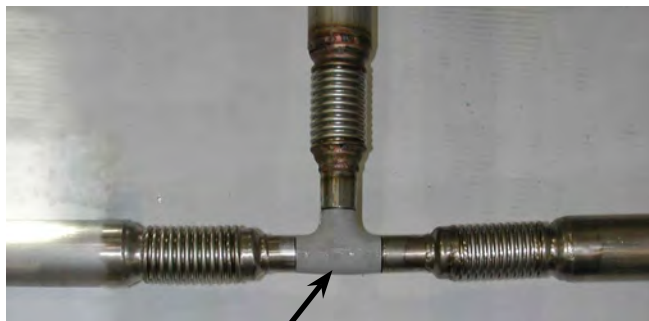

- The stainless steel nipple toe is welded to the reducer.



- After welding, a bubble test should be completed to determine if the weld was successful. If unsuccessful, the joint must be re-worked.
- Use Teflon tape to seal all threaded joints.

- Assemble the gas vent and plumbing components according to the following drawing:

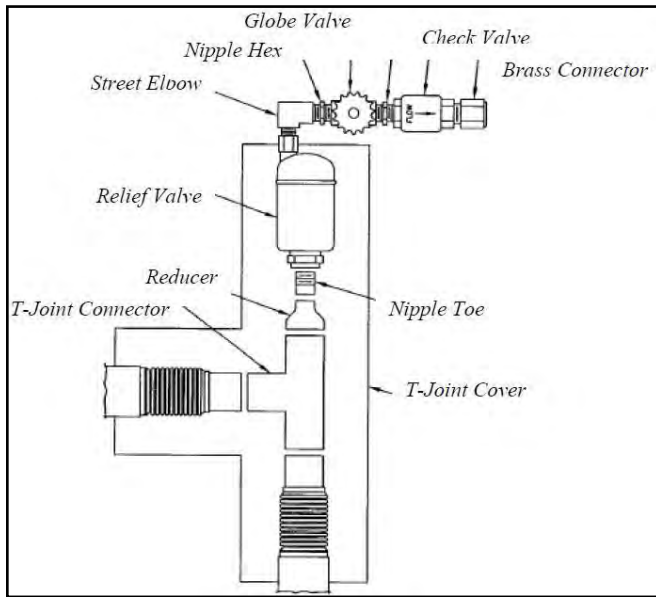

- Stainless Steel Straight Joint Cover
- Brass Relief Valve (150 psig)

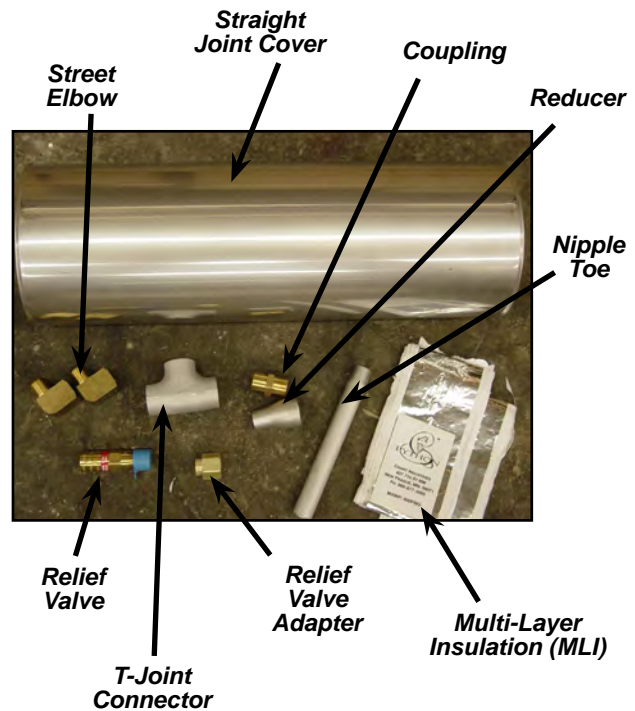

- Apply super-insulation to unjacketed areas.
- Apply foam insulation tape (from insulation kit) to fill voids between the Cryovent assembly and the foam insulation in cover.
- Install T-joint cover. There may be excess insulation tape or foam insulation that needs to be trimmed back. The inside foam of the T-joint cover will also need to be trimmed to allow the plumbing components to fit accordingly.

If any part is missing, wrong or damaged please contact Chart as soon as possible.

### Relief Valve Kit Installation Procedure



**Note:** The relief valve kit is supplied with a relief valve rated to 150 psig. If the application requires a different relief valve setting, contact Chart for assistance.

### Relief Valve Kit

- 1" - PN 11749800
- 2" - PN 11749818
- 3" - PN 11826140

Included in kit:

- T-Joint Connector
- Stainless Steel Reducer
- Stainless Steel Nipple Toe
- Brass Coupling
- 2 - Multi-Layer Insulation (MLI) 40 inches
- Brass Relief Valve Adapter
- 2 - Brass Street Elbow

- Python vacuum insulated pipes are welded using the supplied tee while following the procedure outlined on page 10 "Straight Joints" and "Straight Joint Installation Procedure."
- The stainless steel nipple toe is welded to the reducer.

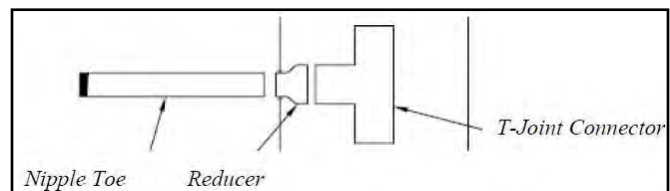

- After welding, a bubble test should be completed to determine if the weld was successful. If unsuccessful, the joint must be re-worked. If no bubbles are present move on to step 4.



4. Use Teflon tape to seal all unthreaded joints.
5. Assemble the plumbing components by the following drawing:

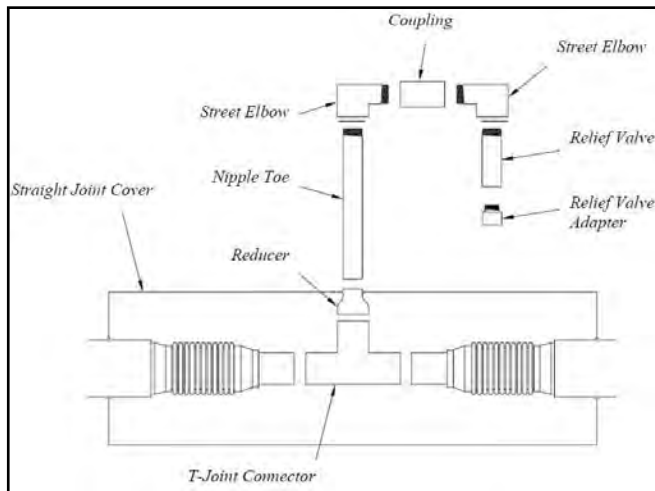

6. Apply super-insulation to unjacketed areas.
7. Apply foam insulation tape (from installation kit) to fill voids between the assembly and the foam insulation cover.
8. Install straight joint cover. There may be excess insulation tape or foam insulation that needs to be trimmed back. The inside foam of the straight joint cover will also need to be trimmed to allow the plumbing components to fit accordingly.

### Trap Kit

1" - PN 11014934

Included in kit:

- Stainless Steel Trap Assembly
- 1/2" Brass Connector
- 5 - Multi-Layer Insulation (MLI) 40 inches
- 1 Box of Rubatex Foam Insulation Tape
- Stainless Steel Straight Joint Cover
- 1/2" Brass Globe Valve

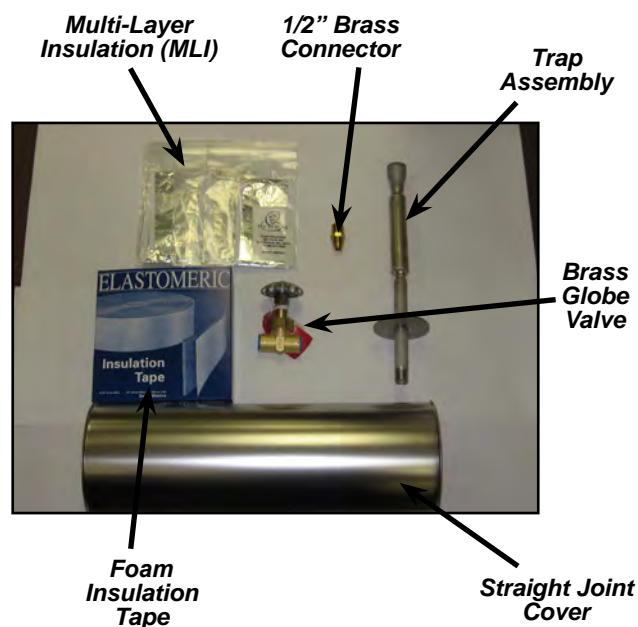

If any part is missing, wrong or damaged please contact Chart as soon as possible.

### Trap Installation Procedure

1. Trap must be installed in a vertical, downward run with 1/2" FPT at bottom.
2. TIG weld the reducer end of the stainless steel trap assembly to the end of the existing Python pipe section.
3. After welding, a bubble test should be completed to determine if the weld was successful. If unsuccessful, the joint must be re-worked.
4. Wrap the pipe from and including the bellows of the existing Python pipe piece down to the disc with at least two layers of the multi-layer super insulation.
5. Wrap the foam insulation tape over the multi-layer insulation until all air space inside the foam cover will be filled.
6. Install the straight foam insulation sleeve over the hand-insulated pipe section such that the foam insulation and stainless steel cover ends at the disc location.
  - a. Trim foam insulation as required to fit over the insulated trap assembly.
  - b. Silicone all joints to prevent moisture leaks into insulation kit.
7. Thread the brass globe valve onto the 1/2" male pipe thread at bottom of stainless steel trap assembly. Use Teflon tape on the pipe threads.

- Thread the brass connector into the 1/2" female pipe thread fitting on the brass globe valve. Use Teflon tape on the pipe threads.



**Warning! PRESSURIZED SYSTEM: A pressure relief valve should be installed anywhere cryogenic liquid or cold gas can be trapped between two points. If the system contains a component or valve that would allow cryogenic liquid or cold gas to be trapped between the globe valve or the trap kit and the valve / component, the installer must install a pressure relief valve for safety purposes. Contact Chart for any clarifications.**

## Nipple Toe

- 1" - PN 1310761
- 2" - PN 1311111
- 3" - PN 1310991



The nipple toes supplied are 3" long. Alternate nipple toe sizes are available upon request.

If any part is missing, wrong or damaged please contact Chart as soon as possible.