

---

# User's Manual

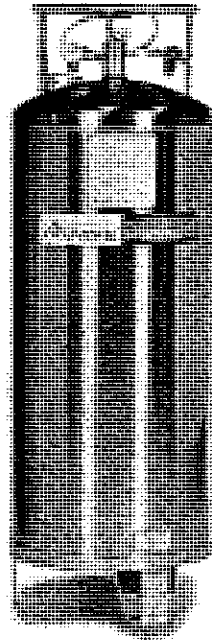

**Carbo-Mizer 400™**  
with Sure-Fill Option™

**MVE®**

---

# Table of Contents

---

---

<b>I</b>	<b>Safety</b> -----	<b>3</b>
	Warnings	
	First Aid And Emergency Action	
	Further Information Sources	
<b>II</b>	<b>General Description</b> -----	<b>4</b>
	System Overview	
	Stationary Versus Portable Installations	
	Storage Tank	
	Tank Plumbing	
	Fill Circuit	
	Pressure Control Circuit	
	Gas Use Or Supply Circuit	
	Safety Vent Or Pressure Relief Circuit	
	Pressure And Contents Gauges	
	CO <sub>2</sub> Fill Box	
	Fill Hose And Vent Line	
	Your Bulk CO <sub>2</sub> Supplier	
<b>III</b>	<b>Parts Identification</b> -----	<b>8</b>
	Carbo-Mizer 400 Storage Tank	
	Stationary Installation Components	
	Portable Installation Components	
<b>IV</b>	<b>Specifications</b> -----	<b>12</b>
	Dimensions	
	Rates And Pressures	
	Design Criteria	
<b>V</b>	<b>Operation And Troubleshooting</b> -----	<b>13</b>
	Ten Facts You Need To Know	
	General Operating Instructions	
	Troubleshooting Guide - Tank	
	Troubleshooting Guide - Fill Box	
<b>VI</b>	<b>Ordering Service And Parts</b> -----	<b>18</b>
	Service And Maintenance	
	Ordering Parts Or Service	
	Important Telephone Numbers	
<b>VII</b>	<b>Warranty</b> -----	<b>19</b>
	Warranty Policy	
	Warranty Claims Procedure	
<b>VIII</b>	<b>System Flow Schematic</b> -----	<b>20</b>

## IMPORTANT SAFETY PRECAUTIONS

All persons responsible for the use and monitoring of this equipment must read and understand the safety and operating information contained in this manual.

## WARNINGS

This tank holds and dispenses carbon dioxide (CO<sub>2</sub>) gas under pressure. Avoid breathing CO<sub>2</sub> or direct contact with CO<sub>2</sub> in any form: gas, liquid or solid. CO<sub>2</sub> gas displaces oxygen and will not support life.

CO<sub>2</sub> is a colorless tasteless gas with only a slight pungent odor and is, therefore, very difficult to detect without special equipment.

Exposure to concentrations of less than 5% for less than 15 minutes can cause physical problems, unconsciousness, injuries or death. Even low concentrations of CO<sub>2</sub> can cause:

- Dizziness, headaches, nausea or disorientation
- Increased respiration or heart rate
- Shortness of breath or rapid suffocation.

CO<sub>2</sub> is heavier than air and can collect in low areas, such as basements, stairwells, and confined spaces. Avoid entry and use caution in areas until thoroughly ventilated if CO<sub>2</sub> leaks or high concentrations of CO<sub>2</sub> are suspected.

The tank safety relief circuit must always be connected to an outdoor vent whenever the tank is indoors, whether it is a stationary or portable system.

The fill box and/or vent must never be located in or above below-ground spaces or stairwells that might be used by humans.

The tank must not block emergency exits, aisles, fire suppression equipment or utility boxes or accesses. All lines or hoses must be away from traffic areas and heat sources and protected from damage. All connections and lines must be leak-free.

Installation and service of this equipment and deliveries of CO<sub>2</sub> should only be performed by qualified professional personnel familiar with CO<sub>2</sub>, mini-bulk liquid CO<sub>2</sub> pressure vessels, and all pertinent safety procedures.

## FIRST AID AND EMERGENCY ACTION

### If inhaled:

- Move to fresh air immediately
- If not breathing, give artificial respiration
- If breathing is difficult, give oxygen
- Get immediate medical attention

### In case of frostbite:

- End exposure at once
- Do not rub or pour water on area
- Get immediate medical attention

### Rescue

- Do not attempt a rescue in areas of high CO<sub>2</sub> concentrations without proper life-support or rescue equipment. Do not become the next victim.
- Thoroughly ventilate areas of possible CO<sub>2</sub> concentration before entering.

### Spills or Leaks

- Evacuate all personnel immediately from affected areas.
- Thoroughly ventilate the area of the spill or leak before entering.
- CO<sub>2</sub> is heavier than air, displaces oxygen and will collect in low or confined areas

## FOR MORE INFORMATION, CONTACT

- Local CO<sub>2</sub> supplier  
or
- Compressed Gas Association  
725 Jefferson Davis Highway, Suite 1004  
Arlington, VA 22202-4100 USA  
Telephone: (703) 412-0900

## II General Description

---

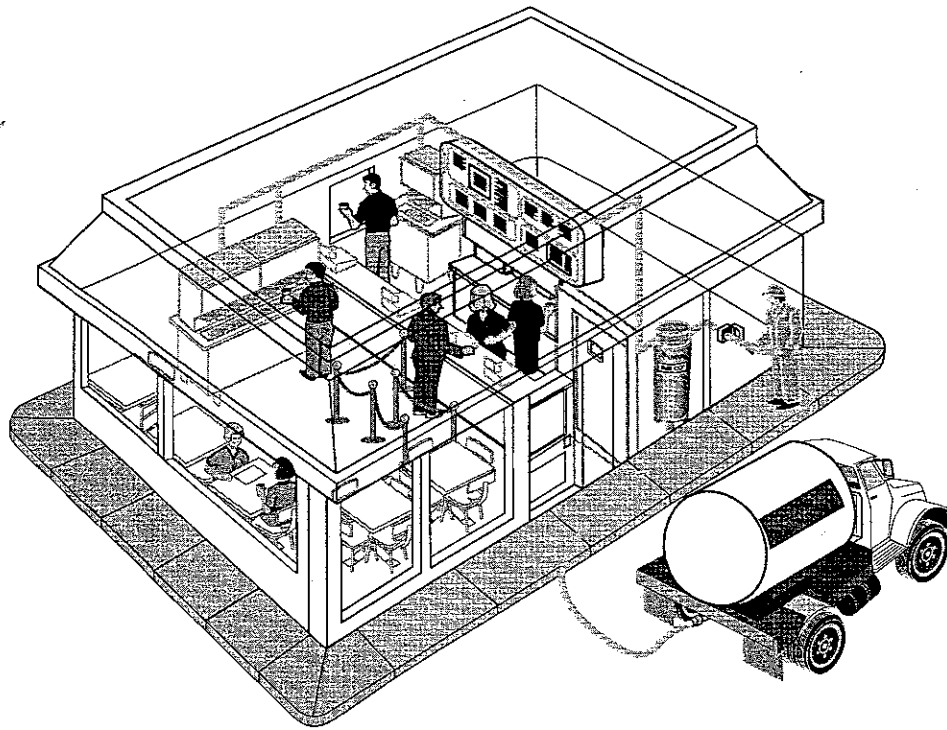

### System Overview

The Carbo-Mizer 400 bulk carbon dioxide (CO<sub>2</sub>) system is designed for the storage and supply of carbon dioxide gas for carbonation or other purposes. The typical Carbo-Mizer system consists of three primary components: the CO<sub>2</sub> storage tank, the CO<sub>2</sub> fill box, and the fill and vent hoses.

### Stationary Versus Portable Installations

The Carbo-Mizer can be operated as a stationary or portable system. The most common system is stationary which employs a permanently installed tank, an outdoor-mounted CO<sub>2</sub> fill box, and the fill and vent hoses. The fill hose and the vent line join the tank to the outdoor fill box.

The CO<sub>2</sub> fill box allows the tank to be filled from outside the building by your CO<sub>2</sub> supplier. The delivery process only takes about 5-10 minutes and does not interrupt the restaurant's operations.

If a fill box cannot be installed on the outside of the building or the distance between the fill box and the tank is too long, then the portable tank model might be an alternative. The portable tank includes a 3-wheeled cart and special plumbing components, including: quick disconnect couplings and a tank-mounted fill fitting, to allow the tank to be temporarily disconnected from the gas supply and vent circuits and moved outdoors for refilling. Before electing to use a portable system, consult with MVE for operational limits and considerations.

# General Description II

## Storage Tank

The Carbo-Mizer 400 tank is a stainless steel low pressure tank that holds 400 pounds (181 kg) of CO<sub>2</sub>. The tank consists of an inner vessel and an outer jacket, similar to a thermos bottle. The space between the two vessels contains a special insulation and has a nearly perfect vacuum. The insulation and vacuum minimize the entry of unwanted heat into the liquid CO<sub>2</sub> stored inside the tank. When carbon dioxide gas is needed for carbonation or another use, it is withdrawn from the top of the tank and dispensed to the beverage or other system.

## Tank Plumbing

The plumbing components on the tank perform five functions:

- Liquid CO<sub>2</sub> Filling
- Pressure Control
- Gas Supply
- Safety Vent or Pressure Relief
- Pressure and Contents Measurement

The CO<sub>2</sub> fill circuit allows liquid CO<sub>2</sub> to be transferred into the tank. As an option, the Carbo-Mizer 400 can be equipped with MVE's patented Sure-Fill assembly to increase CO<sub>2</sub> delivery convenience. The pressure control circuit maintains the minimum needed internal tank pressure to supply the CO<sub>2</sub>. The gas supply circuit dispenses CO<sub>2</sub> gas to the beverage or other use-point system. The vent or relief circuit allows excess pressure to safely exit the tank and the building, if needed. Finally, the contents and pressure gauges indicate the status of the CO<sub>2</sub> inside the tank.

## Fill Circuit

The stationary fill circuit consists of a fill box with a brass fill fitting, a fill hose, a check valve on the tank, and, if ordered, MVE's patented optional Sure-Fill assembly. Liquid CO<sub>2</sub> is transferred into the tank through the brass fill box fitting and the fill hose. The check valve on the tank stops the reverse flow of gas to the fill box.

If the Mizer is not equipped with the Sure-Fill assembly, the check valve on the fill circuit is replaced with an emergency shut-off valve to allow manual venting of any excess pressure built up during filling.

The portable tank fill circuit consists of a brass fill fitting mounted on the top of the tank and secured with a bracket. The portable tank is also available with or without the Sure-Fill assembly.

MVE's patented Sure-Fill assembly allows for fast trouble-free filling without manual venting of excess pressure that might develop during a CO<sub>2</sub> delivery. The Sure-Fill automatically maintains the optimum internal tank pressure during filling by venting excess pressure outdoors through the safety vent and fill box. The Sure-Fill also automatically halts the liquid CO<sub>2</sub> fill process when the tank is full.

## Pressure Control Circuit

The pressure control circuit (also called the "pressure building" or "PB" circuit) maintains the internal operating pressure of the tank. Adequate pressure is needed to supply CO<sub>2</sub> gas and to prevent the carbon dioxide from changing to "dry ice", the solid form of CO<sub>2</sub>.

## II General Description

---

### Pressure Control Circuit (continued)

The pressure building circuit operates by allowing liquid CO<sub>2</sub> to flow through an ambient vaporizer or heat exchange coil located near the bottom of the tank when the inner tank pressure goes below a set pressure. The CO<sub>2</sub> gas produced by the vaporizer returns to the tank and rebuilds the internal tank pressure.

The process of pressure building is controlled by a regulator which senses the internal tank pressure. When the pressure drops below the set point of the regulator (factory set at 125 psi), the regulator opens; liquid CO<sub>2</sub> flows through the vaporizer; and the tank pressure rises. When the internal pressure reaches the regulator's set point, the regulator closes and the flow of liquid CO<sub>2</sub> stops.

During pressure building, the cold liquid carbon dioxide flowing through the vaporizer produces a frost or condensation ring around the bottom of the tank as the CO<sub>2</sub> cools the outside of the tank. When CO<sub>2</sub> is being used, the frost ring is normal. However, when the CO<sub>2</sub> has not been used, such as in the morning before store operations have begun, frost on the bottom of the tank may indicate a CO<sub>2</sub> leak in a line or the beverage or other use-point system.

### Gas Use Or Supply Circuit

Carbon dioxide gas is supplied to the use-point through the gas use or supply circuit. In a Carbo-Mizer CO<sub>2</sub> gas is withdrawn from the gas space above the liquid CO<sub>2</sub> stored in the tank. When demanded at the use-point, CO<sub>2</sub> gas passes through the shut-off valve and into the final line regulator.

The final line regulator controls the gas pressure to the beverage or other use-point system. The factory pressure setting on the Carbo-Mizer's final line regulator is 90 psi, but the pressure may be adjusted depending upon the application. For regular soft drinks the regulator is commonly set between 90 psi - 115 psi.

Additional pressure regulators may be added downstream for other applications such as bag-in-the-box, beer or diet systems. Consult with the use-point equipment manufacturer for the correct pressure regulator and pressure setting(s).

### Safety Vent Or Pressure Relief Circuit

The inner pressure vessel of the Carbo-Mizer tank is designed to meet or exceed the ASME Section VIII, Division 1 pressure vessel code. The ASME code dictates that the tank be protected against excess pressure by a safety relief valve.

MVE uses two safety relief valves for added safety. The primary relief valve is set at 300 psig. The secondary relief valve is set at 450 psig. The relief valves must always be vented outdoors through either the fill box or a vent tube to prevent the concentration of CO<sub>2</sub> within the building. The primary relief valve may occasionally open during CO<sub>2</sub> deliveries or when insufficient CO<sub>2</sub> is being used on a regular basis.

### Pressure And Contents Gauges

The tank pressure gauge measures the internal tank pressure in the top of the tank. The pressure in the tank will range between 115 psi and 300 psi.

# General Description II

## Pressure And Contents Gauges (continued)

The contents or liquid level gauge is a float-type indicator. It displays the approximate amount of CO<sub>2</sub> in the tank by measuring the liquid CO<sub>2</sub> level in the tank. As the level of liquid CO<sub>2</sub> changes in the tank, the movement of a magnetic "float" rod causes the needle on the contents gauge to move, indicating the approximate CO<sub>2</sub> contents.

NOTE: Because float-type indicators cannot actually float on the surface of liquefied CO<sub>2</sub>, they can only give an approximate indication of the CO<sub>2</sub> level and are not highly accurate.

## CO<sub>2</sub> Fill Box

The stainless steel CO<sub>2</sub> fill box is the second major component in a typical stationary Carbo-Mizer system. The purpose of the CO<sub>2</sub> fill box is to provide an accessible filling point for the tank and to vent excess pressure from the tank out of the building. The fill box has a brass fill fitting, a connection for the safety relief valve / vent circuit, and a lockable door.

There are two standard types of fill boxes, a surface-mounted model or a flush-mounted model.

Fill boxes must be mounted outside the building, be easily accessible to the CO<sub>2</sub> supplier for refilling the Carbo-Mizer, and allow for the safe venting of any excess CO<sub>2</sub> gas outdoors. When the Carbo-Mizer is used as a portable system the fill box is replaced by a tank-mounted brass fill fitting and an alternative safety vent line leading outdoors.

NOTE: All tanks, whether stationary or portable, must be vented outdoors so that CO<sub>2</sub> can be safely dispersed outside the building.

## Fill Hose And Vent Line

The last major components in a stationary system are the fill hose and vent line. These two lines join the Carbo-Mizer tank with the outdoor fill box. The fill hose is a special pressure rated line which connects the brass fill fitting in the fill box to the fill circuit on the tank. The vent line is as important as any component in the system. It connects the safety relief valves on the tank to either the outdoor fill box or to an alternative outdoor vent tube.

NOTE: Whether used as a stationary or portable tank, the Carbo-Mizer must always be connected to an outdoor vent line when the tank contains CO<sub>2</sub> and is indoors.

## Your Bulk CO<sub>2</sub> Supplier

Your bulk CO<sub>2</sub> supplier is an important part of your team. Most CO<sub>2</sub> suppliers not only provide you with the timely delivery of CO<sub>2</sub>, but also install and service your Carbo-Mizer system.

When you need service, parts, information, an emergency CO<sub>2</sub> delivery or other CO<sub>2</sub> related assistance, contact your local MVE authorized CO<sub>2</sub> supplier. They will be happy to assist you.

A place has been saved on page 18 of this manual for you to record the name and phone number of your CO<sub>2</sub> supplier, as well as other important service contacts.





# Parts Identification III

**Carbo-Mizer 400 Storage Tank**

**Part No. 1086625**

ITEM	PART NO.	DESCRIPTION	QTY	FUNCTION
17	9094119	Float Rod Assembly with Magnet	1	Indicates liquid CO <sub>2</sub> level in the tank
18	5411622	Spring Retainer	1	Secures spring to float rod for adjustment
19	5411029	Extension Spring	1	Provides tension on float rod
20	2300244	O-Ring, Liquid Level Gauge	1	Seals brass plug to tank
21	5411612	Plug, Brass, Liquid Level Gauge (3/4"-16)	1	Secures the contents gauge to the tank
	10601088	Liquid Level Gauge Assembly	1	Includes items 17, 18, 19, and 21
22	10591422	Gauge, Liquid Level / Contents (Roto-Cal)	1	Indicates approximate liquid CO <sub>2</sub> contents
25	1212962	Brass Plug (1/8" MPT)	1	Seals unused regulator port
30	1717872	Check Valve (3/8" FPT)	1	Isolates CO <sub>2</sub> fill hose from tank
30 Alt.	11082128	Ball Valve (3/8" FPT) [Required for tank without Sure-Fill option]	1	Emergency shut off for fill hose / circuit when tank is not equipped with Sure-Fill
31	1812062	Relief Valve, 450 psig (1/4" MPT)	1	Secondary inner vessel safety relief valve
32	1811252	Relief Valve, 300 psig (1/2" MPT)	1	Primary inner vessel safety relief valve
33a	1716162	Ball Valve (1/4" MPT x 1/4" FPT)	1	Isolates liquid-side of PB regulator
33b	1716162	Ball Valve (1/4" MPT x 1/4" FPT)	1	Isolates gas-side of PB regulator
38	1716162	Ball Valve (1/4" MPT x 1/4" FPT)	1	On / off control for gas supply
39	2112222	Regulator, Pressure Building (PB), 125 psi (1/4" FPT)	1	Regulates internal tank pressure by controlling pressure building (PB) circuit
41	2015179	Pressure Gauge, 0-400 psi (1/4" MPT CBM)	1	Displays internal tank pressure
43	2111682	Regulator, Final Line, 90 psi (1/4" FPT)	1	Controls CO <sub>2</sub> gas pressure to use-point
44	2013262	Pressure Gauge, 0-160 psi (1/8" MPT CBM)	1	Indicates CO <sub>2</sub> gas pressure to use-point
45	1811502	Relief Valve, 130 psi (1/4" MPT X 1/4" MPT 45° Flare)	1	Protects gas supply line and use-point equipment from excess pressure
48	10486454	Elbow (1/2" ODT x 3/8" MPT)	1	Joins 450 psig relief valve to vent circuit
50	10486462	Tee Nylon (1/2" ODT x 1/2" MPT x 1/2" ODT)	1	Joins 300 psig relief valve to vent circuit
51	2811726	Tube, White Nylon (1/2" OD)	2	Joins vent circuit components
52	1611592	Adapter, Pipe-Away (3/8" FPT)	1	Joins 450 psig relief valve to vent circuit
57	1110112	Connector (5/8" ODT x 3/8" MPT-45° Flare)	1	Connects CO <sub>2</sub> fill hose to tank
60a	10586666	Elbow, Brass (1/4" ODT x 1/4" MPT)	1	Joins PB isolation valve to 1/4" OD tubing
60b	10906130	Connector, Brass (1/4" ODT x 1/4" MPT)	1	Joins PB regulator to 1/4" OD tubing
61	2811836	Tubing, Black Nylon (1/4" OD)	1	Joins PB isolation valve and regulator
79	10601045	Sure-Fill™ Assembly (3/4"-16)	1	Controls CO <sub>2</sub> filling and pressure venting
79 Alt.	1213261	Plug (3/4"-16) W/O-ring [Required for tank without Sure-Fill option]	1	Seals Sure-Fill port for tanks not equipped with optional Sure-Fill Assembly
80	10486518	Tee Nylon (1/2" ODT x 1/4" MPT x 1/2" ODT)	1	Joins Sure-Fill assembly to vent circuit
81	1210462	Elbow, Brass, 90° (1/4" MPT x 1/4" FPT)	1	Connects Sure-Fill regulator to valve
82	1716162	Isolation Valve (1/4" MPT x 1/4" FPT)	1	Opens / closes Sure-Fill circuit
83	1812279	Regulator, Sure-Fill, 200 psi (1/4" FPT)	1	Vents excess pressure during CO <sub>2</sub> filling
94	None	Vacuum Pump-Out Port	1	Accesses vacuum space ( <b>Do NOT Open!</b> )
95	None	Vacuum Regeneration Port	1	Accesses vacuum regeneration system
98a	1211702	Street Tee (1/4" MPT x 1/4" FPT x 1/4" FPT)	1	Connects tank pressure gauge to PB circuit
98b	1211702	Street Tee (1/4" MPT x 1/4" FPT x 1/4" FPT)	1	Connects 450 psig relief valve to gas supply line
	3817149	Label, Carbo-Mizer	1	Denotes tank model
	3836609	Label, Operations	1	Describes tank safety and operations

# III Parts Identification

## Stationary Installation Components

**Flush-Mount Fill Box**  
**Part No. 9723139**

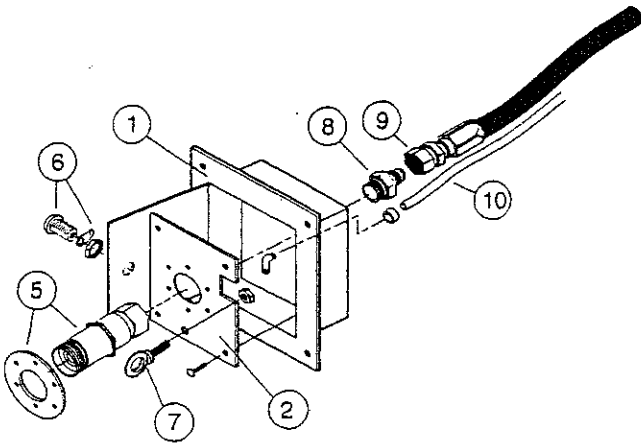

**Surface-Mount Fill Box**  
**Part No. 9722279**

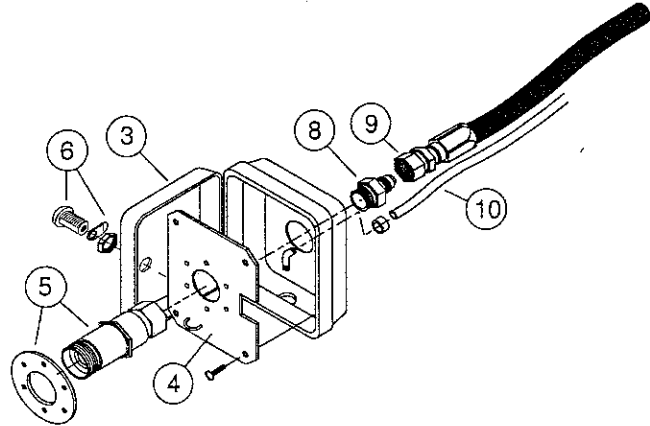

**Fill and Vent Hose Kits**

5 Ft.	10973252
10 Ft.	10973308
15 Ft.	10973324
25 Ft.	10973332
30 Ft.	10973341
50 Ft.	10973359

ITEM	PART NO.	DESCRIPTION	QTY.	FUNCTION
1	9111289	Flush-Mount CO <sub>2</sub> Fill Box	1	Allows outdoor filling and venting of tank
2	10503517	Flush-Mount Fill Box Plate	1	Holds fill fitting
3	8515811	Surface-Mount CO <sub>2</sub> Fill Box	1	Allows outdoor filling and venting of tank
4	5503221	Surface-Mount Fill Box Plate	1	Holds fill fitting
5	1312482	CO <sub>2</sub> Fill Fitting, Brass	1	Connection for CO <sub>2</sub> delivery tank hose
6	10521627	Lock Assembly	1	Locks fill box
7	2952384	Safety Connection Eyelet	1	Safety line connection for delivery hose
8	1111182	Connector (3/4" MPT x 5/8" - 45° Flare)	1	Connects fill hose to fill fitting
9	10969801	CO <sub>2</sub> Fill Hose, 5 ft. (500 MAWP & FDA)	1	Transfers liquid CO <sub>2</sub> from fill box into tank
9	10969819	CO <sub>2</sub> Fill Hose, 10 ft. (500 MAWP & FDA)	1	Transfers liquid CO <sub>2</sub> from fill box into tank
9	10969827	CO <sub>2</sub> Fill Hose, 15 ft. (500 MAWP & FDA)	1	Transfers liquid CO <sub>2</sub> from fill box into tank
9	10969835	CO <sub>2</sub> Fill Hose, 25 ft. (500 MAWP & FDA)	1	Transfers liquid CO <sub>2</sub> from fill box into tank
9	10969843	CO <sub>2</sub> Fill Hose, 30 ft. (500 MAWP & FDA)	1	Transfers liquid CO <sub>2</sub> from fill box into tank
9	10969851	CO <sub>2</sub> Fill Hose, 50 ft. (500 MAWP & FDA)	1	Transfers liquid CO <sub>2</sub> from fill box into tank
10	2811726	Vent Hose (lengths match fill hose)	1	Vents excess tank pressure outdoors

# Parts Identification III

Portable Installation Kit Components

Part No. 10818261

## Vent Line

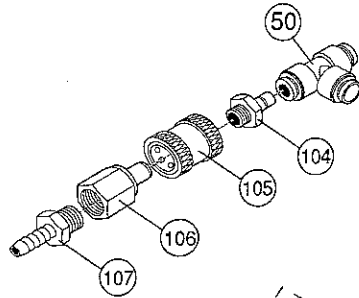

## Fill Fitting

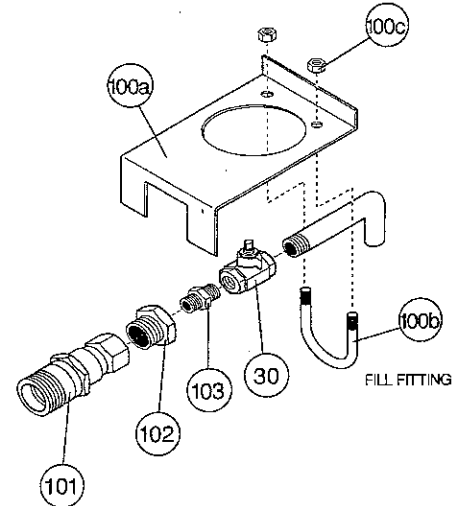

## Gas Use Line

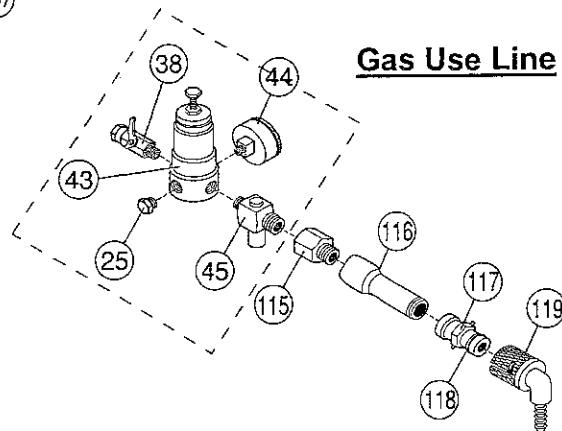

ITEM	PART NO.	DESCRIPTION	QTY.	FUNCTION
25	1212962	Plug 1/8" NPT	1	Seals unused gauge port
30	1717872	Check Valve (3/8" NPT) [With Sure-Fill]	1	Isolates liquid CO <sub>2</sub> fill hose from tank
30 Alt.	10804547	Ball Valve (3/8" NPT) [Without Sure-Fill]	1	Emergency shut-off for CO <sub>2</sub> fill hose / circuit
50	10486462	Tee, Nylon 1/2" OD	1	Vent hose connection tee
100A	10724192	CO <sub>2</sub> Fill Fitting Support Bracket	1	Secures CO <sub>2</sub> fill fitting to tank
100B	10644601	U-Bolt	1	Secures fill fitting bracket
100C	2914071	Locking Nut	1	Secures u-bolt to fill fitting bracket
101	10662041	CO <sub>2</sub> Fill Fitting, Brass (3/4" thread)	1	Connects CO <sub>2</sub> transfer hose to tank CO <sub>2</sub> fill line
102	1212062	Hex Bushing (3/8" FPT x 3/4" MPT)	1	Joins fill fitting to tank
103	1310072	Hex Nipple (3/8" NPT x 1-1/4" long)	1	Joins fill fitting to tank
104	10811528	Plastic Connector (3/8" NPT x 1/2" OD))	1	Secures quick connector to vent line
105	10811552	Quick Connector, Ball-Lock, Female (3/8" FPT x 3/8" Coupler)	1	Allows quick connection & release of vent hose
106	10811544	Quick Connector, Ball-Lock, Male (3/8" FPT x 3/8" Nipple)	1	Allows quick connection & release of vent hose
107	10811536	Hose Barb (3/8" OD x 3/8" MPT)	1	Joins quick connector to vent line
115	10808038	Connector, Brass, 45° (1/4" MPT, 1/4" ODT)	1	Connects relief valve to gas use line
116	10847854	Tank Boss Adapter (1/4" FPT)	1	Connects 2-pin connector to gas use line
117	6511631	Two-Pin Quick Connect, Male	1	Allows connection & release of CO <sub>2</sub> supply line
118	4710619	O-ring (1/2" OD)	1	Seals 2-pin connectors when joined together
119	6511706	Two-Pin Quick Connect, Female (1/4" Barb)	1	Allows connection & release of CO <sub>2</sub> supply line
	9711449 (Not Shown)	Portable Handling Cart with Towing Handle (20" OD tanks only)	1	Allows movement of portable tanks over smooth level surfaces

# IV Specifications

## Carbo-Mizer 400

### Dimensions

Diameter	20 in.	(508 mm)
Height (Standard Stationary Model)	66 in.	(1677 mm)
Empty Weight	305 lb.	(138 kg)
Full Weight	705 lb.	(320 kg)
Gross Capacity	46 gal.	(175 liters)
Storage Capacity	400 lb.	(181 kg)
Gas Use Regulator Connection	1/4" 45° Flare Fitting	
Fill Line Connection	5/8" Male 45° Flare Fitting	
Vent Line Connection	1/2" OD Tubing Compression	

### Rates and Pressures

Continuous CO <sub>2</sub> Delivery Rate	5.5 lb./hr.*	(2.5 kg/hr.)*
Peak Flow Rate	10.0 lb./hr.*	(4.5 kg/hr.)*
Evaporation Rate	2.5 lb./day	(1.1 kg/day)
Max. Allowable Working Pressure (MAWP)	300 psig.	(20.7 bar g)
Primary Relief Valve Setting	300 psig.	(20.7 bar g)
Secondary Relief Valve Setting	450 psig.	(31.0 bar g)
Sure-Fill Regulator Setting	200 psig	(13.8 bar g)

### Design Criteria

Design Specifications	ASME Section VIII, Division 1
Fill System	"Low-Loss" Single Line
Patented Sure-Fill System	Recommended Option
Patented Collection & Purge System	Recommended Option
Insulation Type	Super Insulation with Vacuum
Pressure Control System	Pressure Building (PB) Circuit
Liquid Level Gauge	Float Type: Magnetic Roto-Cal
Outer Vessel Material	Stainless Steel
Inner Vessel Material	Stainless Steel
Fill Fitting	3/4" OD Threaded Brass Coupling
Fill Box Design	Surface-Mount or Flush-Mount
Floor Mount Design**	Six Inch Permanent Legs

### **Footnotes:**

\* Equals approximately 350 - 16 oz. drinks per hour continuous and 640 - 16 oz. drinks per hour peak

\*\* Flat footing base or 3-wheel cart available as options

# Operation and Troubleshooting V

## Ten (10) Facts You Need To Know

1. The tank's normal internal operating pressure (Item 41) is between 110 psi and 150 psi.
2. The tank pressure can be as high as 300 psi after a delivery, but returns to its normal operating pressure after several days of normal CO<sub>2</sub> use.
3. The gas supply pressure (Item 44) is normally between 90 psi and 120 psi.
4. Frost or condensation on the tank is normal during periods of CO<sub>2</sub> use.
5. Frost or condensation on the tank before starting the daily use of CO<sub>2</sub> is a sign of a CO<sub>2</sub> leak. Have the leak fixed.
6. A full tank holds 400 pounds of CO<sub>2</sub>. Typical Carbo-Mizer users use 40 - 100 pounds of CO<sub>2</sub> per week.
7. The contents gauge (Item 22) displays the approximate amount of liquid CO<sub>2</sub> in the tank.
8. Never allow the internal tank pressure (Item 41) to drop below 61 psi. CO<sub>2</sub> turns to dry ice below 61 psi. Stop using CO<sub>2</sub> from the Carbo-Mizer if the pressure reaches 70 psi or less.
9. Isolation or shut-off valves are open when the valve handle is parallel to the valve body and the line. Valves are closed when the handle is perpendicular to the valve body and the line.
10. Check the tank every day before starting operations and CO<sub>2</sub> use. Check for:
  - CO<sub>2</sub> leaks (See "Safety".)
  - Pressure readings (Items 41 and 44)
  - CO<sub>2</sub> contents (Item 22)
  - Abnormal frost or condensation
  - Anything unusual.

## General Operating Instructions

- ◆ Always use caution around CO<sub>2</sub>. Read and understand the "Safety" section of this manual.
- ◆ The Carbo-Mizer system does not require adjustment under normal operating conditions.
- ◆ Check the tank daily before using CO<sub>2</sub>. See need-to-know fact number 10.
- ◆ In an emergency, the flow of CO<sub>2</sub> from or through the Carbo-Mizer can be stopped by closing the isolation or shut-off valves. Flow of CO<sub>2</sub> can be stopped by closing the following valves:
  - Item 38 to stop the flow of gas from the tank to the beverage or other use-point system.
  - Item 30 to stop the flow or leakage of CO<sub>2</sub> out of the tank via the fill hose and/or the brass fill fitting in the outdoor fill box.
  - Items 33a and/or 33b to stop the flow of CO<sub>2</sub> through the pressure control-pressure building (PB) circuit.
- ◆ For CO<sub>2</sub> equipment problems, call your CO<sub>2</sub> supplier or a CO<sub>2</sub> service specialist.
- ◆ Before calling for service or troubleshooting assistance, please have the following information at hand:
  - Serial number of the tank
  - Description of the problem
  - Readings from the contents gauge (Item 22), the tank pressure gauge (Item 41) and the final line pressure gauge (Item 44).
  - Any special observations (for example: unusual frosting, events related to the problem, etc.)

# V Operation and Troubleshooting

## TROUBLESHOOTING GUIDE - TANK

PROBLEM	PROBABLE CAUSE	CORRECTIVE ACTION
<p>No CO<sub>2</sub> to carbonator or other use-point system.</p> <p>OR</p> <p>Carbonated drinks are flat.</p>	Bulk CO <sub>2</sub> tank empty.	<ol style="list-style-type: none"> <li>1. Switch to emergency CO<sub>2</sub> gas cylinder.</li> <li>2. Call CO<sub>2</sub> supplier for delivery.</li> </ol>
	Isolation valve (#38) to final line regulator is closed.	<ol style="list-style-type: none"> <li>1. Open valve or valves as needed.</li> </ol>
	Tank pressure (#41) is low (110 psi or less).	<ol style="list-style-type: none"> <li>1. Switch to emergency CO<sub>2</sub> gas cylinder</li> <li>2. Stop CO<sub>2</sub> withdrawal from bulk CO<sub>2</sub> tank. Close isolation valve (#38).</li> <li>3. If tank pressure fails to rebuild, see section on low tank pressure.</li> </ol>
	Pressure building regulator (#39) not operating properly.	<ol style="list-style-type: none"> <li>1. Check isolation valves (#33a &amp; b) to insure they are open. Valve handles should be parallel with the line.</li> <li>2. Regulator is set too low, plugged, or faulty. Call CO<sub>2</sub> service agent</li> </ol>
	Unknown	<ol style="list-style-type: none"> <li>1. Call CO<sub>2</sub> service agent.</li> </ol>
Frost on the bottom or sides of the tank.	A normal condition during or following CO <sub>2</sub> use.	NONE
	Leak in gas supply lines, beverage system and/or CO <sub>2</sub> fill box. (Frost is present on tank after extended periods with no CO <sub>2</sub> use.)	<ol style="list-style-type: none"> <li>1. See "<b>Safety</b>". Evacuate &amp; ventilate. Check for frost in the morning before CO<sub>2</sub> has been used. If possible, locate and correct leak.</li> <li>2. Call appropriate equipment service agent.</li> </ol>
Frost on the top of the tank.	Normal condition during periods of CO <sub>2</sub> use.	NONE
	CO <sub>2</sub> leak from tank plumbing, CO <sub>2</sub> fill box, tank safety system and/or beverage system. (Frost is present after extended periods with no intentional CO <sub>2</sub> use.)	<ol style="list-style-type: none"> <li>1. See "<b>Safety</b>". Evacuate &amp; ventilate the room.</li> <li>2. Check for frost in the morning prior to any CO<sub>2</sub> use &amp; other indicators, such as: high CO<sub>2</sub> usage, frost on sides of the tank, low tank pressure, etc. Locate &amp; correct leak if possible.</li> <li>3. Call appropriate service agent.</li> </ol>
<p>Routinely low tank pressure.</p> <p>(#41 below 125 psi)</p>	Pressure building regulator (#39) set too low.	<ol style="list-style-type: none"> <li>1. Call CO<sub>2</sub> service agent for service.</li> </ol>
	PB shut-off valve (#33a & b) closed.	<ol style="list-style-type: none"> <li>1. Open valve by turning handle parallel to line.</li> </ol>
	CO <sub>2</sub> leak from tank plumbing, CO <sub>2</sub> fill box and/or tank safety system	<ol style="list-style-type: none"> <li>1. See "<b>Safety</b>". Evacuate &amp; ventilate the room.</li> <li>2. Call CO<sub>2</sub> service agent.</li> </ol>
	PB plugged or Unknown	<ol style="list-style-type: none"> <li>1. Call CO<sub>2</sub> service agent.</li> </ol>

# Operation and Troubleshooting V

## TROUBLESHOOTING GUIDE - TANK

PROBLEM	PROBABLE CAUSE	CORRECTIVE ACTION
Routinely high tank pressure. (#41 over 200 psi)	Normal condition for several days following a CO <sub>2</sub> delivery.	NONE
	Normal when little or no CO <sub>2</sub> is used.	NONE
	Pressure builder regulator (#39) set too high.	1. Call CO <sub>2</sub> service agent.
	Tank has a weak vacuum.	1. Call CO <sub>2</sub> service agent.
High CO <sub>2</sub> usage.	Increased beverage sales or CO <sub>2</sub> use.	NONE
	Tank pressure (#41) routinely too high.	1. See section on tank pressure too high.
	CO <sub>2</sub> leak from tank plumbing, CO <sub>2</sub> fill box, gas lines, and/or beverage or other use-point equipment.	1. See "Safety". Evacuate & ventilate room. 2. Locate leak & correct if possible 3. Call appropriate CO <sub>2</sub> or service agent.
	Error in CO <sub>2</sub> delivery or supplier invoice.	1. Check CO <sub>2</sub> usage history / pattern against supplier invoices. Consult CO <sub>2</sub> supplier.
CO <sub>2</sub> tank will not fill.	CO <sub>2</sub> tank is already full.	NONE
	CO <sub>2</sub> fill or check valve (#30) is faulty.	1. Consult CO <sub>2</sub> supplier or service agent.
	Brass fill fitting in CO <sub>2</sub> fill box and/or on truck's delivery hose is faulty.	1. Consult with CO <sub>2</sub> supplier or service agent. 2. Have brass fill fitting(s) replaced, if needed.
	Pressure differential between store tank and delivery tank is too small. (At start of fill, store tank pressure should be 110 psi - 150 psi and delivery tank should be 275 psi - 300 psi).	1. Verify delivery tank pressure is at least 275 psi and store tank pressure (#41) is between 110 psi - 150 psi. 3. Vent store tank to lower pressure if needed. 4. NEVER vent store tank pressure to lower than 125 psi.
	Sure Fill™ assembly is not venting excess gas. Tank pressure did not return to normal operating pressure.	1. Tank pressure must return to below 200 psi between filling times allowing the internal ball to fall into the open position. 2. Consult CO <sub>2</sub> supplier.
	Leak in Sure Fill™ assembly	1. Correct leak. Leak check. 2. Contact CO <sub>2</sub> supplier.
	Delivery tank is empty.	1. Consult supplier. Arrange another delivery.
	Delivery tank empty or truck delivery hose is obstructed, e.g. vehicle stopped on hose or hose is bent.	1. Ask driver to make another delivery or clear obstruction or wait until obstruction clears.

# V Operation and Troubleshooting

## TROUBLESHOOTING GUIDE - TANK

PROBLEM	PROBABLE CAUSE	CORRECTIVE ACTION
Hissing sounds or evidence of gas leaking.	Normal for short periods of time from some regulators and relief valves.	<ol style="list-style-type: none"> <li>1. See "<b>Safety</b>". Evacuate and ventilate room / area.</li> <li>2. Observe leak, if it is not large <u>and</u> does not last long <u>and</u> occur frequently, no action may be needed.</li> <li>3. If above combined conditions do not exist, call CO<sub>2</sub> service agent and see "<b>Safety</b>".</li> </ol>
	Large leaks, leaks from elsewhere in the system, sustained leaks, or frequent leaks are <b>not</b> normal.	<ol style="list-style-type: none"> <li>1. See "<b>Safety</b>".</li> <li>2. Evacuate all personnel from affected areas.</li> <li>3. Ventilate room / area.</li> <li>4. Call CO<sub>2</sub> service agent.</li> </ol>
Final line / gas use pressure gauge (#44) is below 90 psi.	Final line regulator (#43) intentionally set lower by beverage service agent.	NONE
	Final line regulator (#43) not operating in proper pressure range.	<ol style="list-style-type: none"> <li>1. Call CO<sub>2</sub> service agent.</li> </ol>
	Final line pressure gauge (#44) damaged or faulty.	<ol style="list-style-type: none"> <li>1. Call CO<sub>2</sub> service agent.</li> </ol>
	One or more of the causes listed in "no CO <sub>2</sub> " or "flat drinks" problem section.	<ol style="list-style-type: none"> <li>1. See problem sections above regarding "no CO<sub>2</sub>", "flat drinks", etc.</li> <li>2. Call CO<sub>2</sub> service agent.</li> </ol>

For CO<sub>2</sub> equipment problems, call your CO<sub>2</sub> supplier or an authorized CO<sub>2</sub> service specialist.



# Operation and Troubleshooting V

## TROUBLESHOOTING GUIDE - FILL BOX

PROBLEM	PROBABLE CAUSE	CORRECTIVE ACTION
Fill box door will not close, lock, or open.	Wrong key.	<ol style="list-style-type: none"> <li>1. Verify correct key and retry.</li> <li>2. Contact CO<sub>2</sub> supplier for spare key.</li> <li>3. Order new key from MVE.</li> </ol>
	Lock dirty or damaged.	<ol style="list-style-type: none"> <li>1. Clean and oil lock</li> <li>2. Replace lock, if necessary</li> </ol>
Brass fill fitting in fill box leaking or hissing.	Particle of ice or debris caught in fill fitting poppet.	<ol style="list-style-type: none"> <li>1. If driver is still on site, reconnect CO<sub>2</sub> delivery hose and then disconnect.</li> <li>2. If driver not available, carefully press poppet with dull instrument to reseal poppet.</li> <li>3. If leak continues after line warms up, close tank fill isolation valve (#30) and call service agent to replace fitting.</li> </ol>
	Fitting is defective or sealing surface is worn due to normal wear and tear.	<ol style="list-style-type: none"> <li>1. Close tank fill isolation valve (#30) and call service agent to replace fitting.</li> </ol>
Brass fill fitting threads are worn or stripped.	Normal wear & tear. Fill fitting must be replaced.	<ol style="list-style-type: none"> <li>1. Contact CO<sub>2</sub> service agent to replace fitting.</li> </ol>
	Cross threading the coupler with the CO <sub>2</sub> delivery hose coupler	<ol style="list-style-type: none"> <li>1. Contact CO<sub>2</sub> service agent to replace fitting.</li> </ol>
CO <sub>2</sub> is venting from fill box.	Normal during a CO <sub>2</sub> delivery.	NONE
	Normal for short periods of time if tank pressure is at or over 300 psi	<ol style="list-style-type: none"> <li>1. NONE if for short period(s) of time</li> <li>2. If tank pressure consistently over 300 psi, see section on tank pressure too high.</li> </ol>
	Fill fitting is not sealing properly.	<ol style="list-style-type: none"> <li>1. Call CO<sub>2</sub> service agent to replace fitting.</li> </ol>

For CO<sub>2</sub> equipment problems, call your CO<sub>2</sub> supplier or an authorized CO<sub>2</sub> service specialist.

# VI Ordering Service And Parts

## Service and Maintenance

1. Service or maintenance work on the Carbo-Mizer 400 should be performed only by MVE trained and authorized professional service agents who are familiar with CO<sub>2</sub>, mini-bulk liquid CO<sub>2</sub> pressure vessels, and all pertinent safety and service procedures. MVE recommends the use of MVE approved replacement parts. Contact MVE for the name of the authorized service agent(s) in your area.
2. Before calling for service or troubleshooting assistance, please have the following information at hand:
  - Serial number of the tank
  - Description of the problem
  - Readings from
    - the contents gauge (Item 22),
    - the tank pressure gauge (Item 41) and
    - the final line pressure gauge (Item 44).
  - Any special observations (for example: unusual frosting, events related to the problem, etc.)
3. MVE recommends that a thorough preventative maintenance check be performed on the Carbo-Mizer system by a qualified professional service agent at least once every two years. The check should be done to insure safety and the optimal performance of the system.
4. The Carbo-Mizer has no user serviceable parts. All service work should be performed by an authorized professional service agent.
5. NOTE: Any attempt to service the equipment by an unauthorized person or to perform unauthorized modifications will void the warranty.

## Ordering Parts Or Service

For parts or service contact your local authorized MVE CO<sub>2</sub> supplier or equipment service agent. To insure prompt processing of your order, list each item separately, taking care to specify the quantity, the part number, and the description of each item being ordered.

## Important Telephone Numbers

Company	Contact Person	Phone Number
CO <sub>2</sub> Supplier	_____	_____
	<u>After-Hours / Emergency Number</u>	_____
CO <sub>2</sub> Service Agent	_____	_____
CO <sub>2</sub> Installer	_____	_____
MVE Customer Service	(952) 882-5000 or	(800) 247-4446 {toll free in US}
MVE Technical Service	(952) 882-5000 or	(800) 253-1769 {toll free in US}

# WARRANTY VII

## WARRANTY POLICY

MVE, Inc. (MVE) warrants to the Purchaser the Carbo-Mizer 400 bulk CO<sub>2</sub> system equipment for 90 (ninety) days from the MVE invoice date, that said equipment shall be free from any defects in workmanship and materials. MVE also warrants the reliability of the vacuum in the Carbo-Mizer 400 tank for 5 (five) years from the date of the original MVE invoice.

Purchaser agrees that as a pre-condition to any MVE liability hereunder, Purchaser or its appointed agents shall fully inspect all goods immediately upon delivery and shall give MVE written notice of any claim or purported defect within ten (10) days after discovery of such defect.

As a further pre-condition to any MVE liability hereunder, both parts replacement and labor must be supplied by an approved MVE service company. MVE may elect to repair or replace such equipment or any defective component or part thereof which proves to be defective, or to refund the purchase price paid by the original Purchaser. MVE shall not be liable for defects caused by the effects of normal wear and tear, erosion, corrosion, fire, explosion, misuse, or unauthorized modification.

Alterations or repair by others than those designated and approved by MVE or operation of such equipment in a manner inconsistent with MVE accepted practices and all operating instructions, unless pre-authorized in writing by MVE, shall void this Warranty.

MVE's sole and exclusive liability under this Warranty is to the Purchaser and shall not exceed the lesser of the cost of repair, cost of replacement, or refund of the net purchase price paid by the original Purchaser.

MVE is not liable for any losses (including CO<sub>2</sub>), damages, or costs of delays, including incidental or consequential damages. MVE specifically makes no warranties or guarantees, expressed or implied, including the warranties of merchantability or fitness for a particular purpose or use, other than those warranties expressed herein.

## WARRANTY CLAIMS PROCEDURE

1. All warranty claims must be previously authorized by: MVE, Inc. Telephonic / electronic approval may be obtained by contacting Restaurant Products Technical Services at:

- Telephone: 952-882-5000  
800-253-1769  
(toll free in U.S.)
  - Facsimile: 952-882-5185
- or by writing to:

MVE, Inc.  
Restaurant Technical Services  
3505 County Road 42 West  
Burnsville, MN 55306-3803  
USA

2. Authorization must be obtained from MVE prior to shipping any equipment to MVE facilities. The model and serial number of the tank must be provided in order to process the return. If approved, a Return Material Authorization (RMA) number will be provided. The RMA number must be prominently indicated on the packing slip and any packaging which accompanies the goods being returned. The customer returning the goods is responsible for all freight, proper packing, and any damage incurred during shipment of the goods back to MVE.

# VIII System Flow Schematic

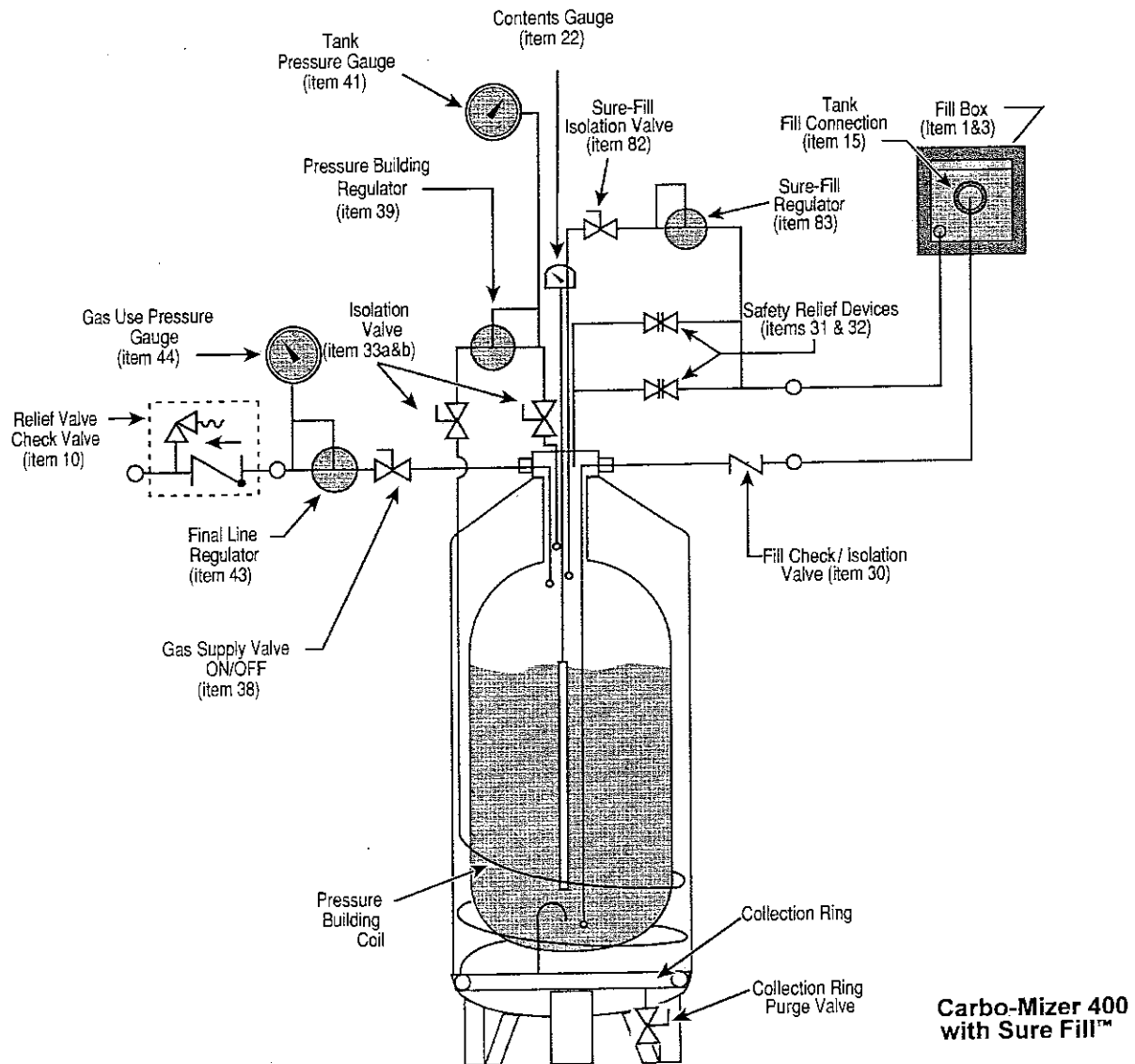

# MVE®

MVE, Inc.  
 3505 County Road 42 West  
 Burnsville, MN 55306 - 3803 USA