



Installation Manual
Hybrid Bulk Syrup System
SSM-80G



Designed and Built by:

Chart Inc.

1300 Airport Dr.

Ball Ground, GA 30107 USA

(800) 400-4683



Contents

Revision Log	iv
Preface	1
General	1
Installation Manual	1
Terms	2
Acronyms / Abbreviations.	2
Safety	3
General	3
CO ₂ Monitoring Systems	3
First Aid and Emergency Action	4
Installation.	5
Installation Responsibilities	5
Required Tools and Supplies	5
Installation Tools	5
Required Supplies and Parts	5
General Installation Guidelines	6
Locating Hulk Syrup Tank Equipment	8
Installation of Syrup Tanks	9
Installation of Clean-In-Place Panel.	10
Installation of Lines	10
CO ₂ Supply Line From Bulk CO ₂ Tank to CIP	12
Tank Pressure Line (CO ₂) from CO ₂ Source to Bulk Syrup Tanks	13
Sanitize Line (Spray Head) from CIP to Bulk Syrup Tanks	13
Sanitize Line (Fill Fitting) from CIP to Bulk Syrup Tanks.	14
Water Supply Line from Beverage Machine to CIP	14
Vent Line from Bulk Syrup Tanks to Outdoors.	14
Drain Line from Bulk Syrup Tanks to Sanitary Floor Drain	15
Syrup Supply Line from Syrup Tanks to Beverage Machine.	15
Emergency CO ₂ (or Air) Line from Beverage Machine to Bulk Syrup Tanks	15
Fill Box Pressure Line from Bulk CO ₂ Tank to CO ₂ Fill Box	16
Final Line Installation Steps	16
Special Instructions for Los Angeles and San Diego Regions	16
Installation of Drain Line Stand Pipe	16
Installation of Labels	17
System Testing and Operation	19
System Inspection and Testing	19
Operating Instructions.	20
Parts	21
Parts Lists	21
Bulk Syrup Tank	21
Hybrid Bulk Installation Kit	21
Hybrid Bulk Label Kit.	23
Hybrid Bulk Tubing Kit	23
Special Installation Parts	23
Defective or Missing Parts	23
Component Identification	24
Bulk Syrup Tank	24
InterBulk Clean-In-Place Panel (CIP)	26
Miscellaneous Components	27

Warranty 29
Warranty Policy 29
Warranty Claims Procedure 30

Revision Log

Revision Level	Date	Description
F	08/28/2018	Bring into the new format



Preface

General

The Chart Bulk Syrup System is designed to provide sanitary storage and continuous supply of syrup for fountain beverages. The Hybrid Bulk Syrup System consists of two or more stainless steel bulk syrup tanks. Each tank holds 75 gallons of syrup and replaces 15 five gallon syrup tanks or BIB boxes. A Hybrid system also features a semi-automatic InterBulk clean-in-place panel (CIP) for sanitizing the tanks before each refill.

The tank works very much like five gallon tanks. Syrup is fed to the beverage machine by pressurized CO₂. When one tank is close to being empty, it is jumpered in series to another full tank. This ensures a continuous supply of syrup without changing empty tanks or boxes.

Before refilling an empty syrup tank, it must be sanitized. The empty tank is connected to the InterBulk clean-in-place (CIP), which rinses, sanitizes and purges the tank, preparing it for the next bulk syrup delivery.

Bulk syrup deliveries are part of the store's regular delivery service. The sanitized tank is connected by a syrup delivery hose to a 75 gallon bulk delivery tank located in the delivery truck. The syrup tank is always refilled with 75 gallons of syrup during each ordered bulk syrup delivery.

There are two models of Chart syrup tanks. The first is the permanently installed, non-mobile, model SSM-80G, which is the most commonly used model. The second model is the SSM-80G CB, which is a mobile tank mounted on a caster base with a handle bar. The mobile SSM-80G CB operates exactly like the permanently installed tank, except it can be moved within the building for filling, sanitizing and/or syrup dispensing.

To operate the system, a low pressure CO₂ gas is required. The most common source of CO₂ for bulk syrup is a Chart approved bulk CO₂ tank. If the store does not have a Chart tank or bulk syrup compatible bulk CO₂ tank, then it may use CO₂ from the 90 psi CO₂ supply in the beverage machine and the distribution center delivery truck must supply compressed air for the syrup delivery.

To assure proper operation and reliability, the Hybrid Syrup System must be installed in accordance with these instructions. Failure to do so may void the warranty. Deficiencies in the installation are the responsibility of the installer (or in some cases, the store owner or management).

Installation Manual

This manual covers the installation of the Chart Hybrid Bulk Syrup System, often referred to as "McBulk". The specific components of the system described in this manual include:

- SSM-80G Bulk Syrup Tank PN 10667511
- SSM-80G CB Mobile Bulk Syrup Tank PN 10667503
- Hybrid Bulk Syrup Installation Kit PN 10667431 with:
 - InterBulk Syrup Clean-In-Place Panel PN 97-2310-9
 - Hybrid Bulk Syrup Label Kit PN 10667440
- Hybrid Bulk Syrup Tubing Kit PN 10667466

In addition, this manual also describes installation criteria and details for components associated with or connected to the syrup system, but which are not part of the bulk syrup system and not necessarily supplied by Chart. These associated components include:

- The beverage machine
- The bulk CO₂ system

For further details regarding the installation or service of these components consult the manufacturers' installation and service manuals.

This manual does not cover equipment or installations for the five boroughs of New York City, which must meet special conditions and standards set by the New York City Fire Department.

This manual is intended for use by experienced personnel only.

No attempt should be made to install or use this equipment until both this manual and the user's equipment manual have been read and fully understood.

Terms

Throughout this manual safety precautions will be designated as follows:



Warning! *Description of a condition that can result in personal injury or death.*



Caution! *Description of a condition that can result in equipment or component damage.*



Note: *A statement that contains information that is important enough to emphasize or repeat.*

Acronyms / Abbreviations

The following acronyms / abbreviations are used throughout this manual:

ASME	American Society of Mechanical Eng.
BAR	Pressure (metric)
CIP	Clean-In-Place
CO ₂	Carbon Dioxide
FPT	Female Pipe Thread
ID	Inner Diameter
Kg	Kilograms
MPT	Male Pipe Thread
OD	Outer Diameter
PN	Part Number
PSI	Pounds per Square Inch
SCFH	Standard Cubic Feet per Hour
SS	Stainless Steel



Safety

General

The system described in this manual holds and dispenses carbon dioxide (CO₂) gas under pressure. All persons using this equipment must read and understand the operation and safety information contained in this manual and must be adequately trained to operate this equipment.



Warning! *Asphyxiation hazard. Carbon dioxide gas can cause serious injury or death. Do not breathe CO₂ gas. Avoid entering tank area if a leak is suspected and thoroughly ventilate the area.*



Warning! *Frostbite hazard. Contents are extremely cold and can cause frostbite. Do not touch liquid, ice, or ice crystals on or near tank. Stay away from escaping gas.*



Warning! *CO₂ vapors in air may dilute the concentration of oxygen necessary to support or sustain life. Exposure to such an oxygen deficient atmosphere can lead to unconsciousness and serious injury, including death.*

CO₂ gas is a colorless, odorless, tasteless gas that displaces oxygen and does not support life. The gas is difficult to detect without the assistance of special equipment. Avoid breathing or contacting CO₂ in gas, liquid or solid form.

Exposure to concentrations of less than 5% can cause physical symptoms including unconsciousness, injuries or death. Even low concentrations of CO₂ can cause:

- Dizziness, headaches, nausea or disorientation
- Increased respiration or heart rate
- Shortness of breath or rapid suffocation

CO₂ is heavier than air and can collect in low areas such as basements, stairwells, and confined spaces. Avoid entry into areas where CO₂ leaks or high concentrations of CO₂ are suspected. Enter those areas with caution only after they have been thoroughly ventilated.

Whenever the tank is inside a building it's safety relief circuit must be connected to an outdoor vent typically in the fill box. The fill box and/or vent must never be located in or above any below-ground spaces or stairwells. The tank must not block emergency exits, aisles, fire suppression equipment or utility boxes or accesses. CO₂ lines or hoses must be located away from traffic areas and heat sources and must be protected from potential causes of damage. All connections, lines, and components must be leak-free.

This equipment should be installed and serviced only by professional agents who are qualified to work with CO₂ and the mini-bulk liquid CO₂ storage tanks. They should be familiar with all pertinent safety procedures.

Handle liquid so that it will not splash or spill. Protect your eyes and cover skin where the possibility of contact with liquid CO₂, cold pipes and equipment, or cold gas exists. Safety goggles or a face shield should be worn at all times when connecting to fill connections, while filling the tank and during disconnection from the fill connection. Clean, insulated gloves that can be easily removed and long sleeves are recommended for arm and hand protection. Cuffless trousers should be worn over the shoes to shed spilled liquid.

CO₂ Monitoring Systems

The CO₂ Storage Safety Alarm is designed to protect people who work near carbon dioxide stored in closets or confined spaces.

CO₂ Meter has both an audible alarm and flashing visual indicator when CO₂ concentrations reach a pre-set level. Three built-in relays can be used to control ventilation, your HVAC system or even be wired to an alarm panel to notify your alarm company or the fire department.

First Aid and Emergency Action

If inhaled:

- Move to fresh air immediately
- If not breathing, give artificial respiration
- If breathing is difficult, give oxygen
- Get immediate medical attention

In case of frostbite:

- End exposure immediately
- Do not rub or pour water on the affected area
- Get immediate medical attention

Rescue:

- Do not attempt a rescue in areas of high CO₂ concentrations without proper self contained breathing apparatus.
- Thoroughly ventilate areas of possible high CO₂ concentration before entering.

In case of spills or leaks:

- Evacuate all personnel immediately from affected areas
- Thoroughly ventilate the area of the spill or leak before entering



Installation

Installation Responsibilities

The installer is responsible for the following:

1. Proper installation of the bulk syrup system in accordance with these instructions and the requirements of the store management.
2. Communicating with the store to arrange the install schedule and negotiate an installation fee.
3. Inspection of the Hybrid Bulk components for damaged or missing parts.
4. Supplying the tools and supplies listed in the Required Tools and Supplies section below.
5. Communicating with the store during installation.
6. Complying with all relevant local codes and guidelines.
7. Testing the Hybrid Bulk System for proper operation.
8. Explaining and demonstrating the Hybrid Bulk System to the store management.
9. Completing any required documentation, including the final inspection checklist.
10. Cleaning the installation site before leaving.

The store is responsible for the following:

1. Ordering the Bulk system from Chart.
2. Contracting an installer to install the Bulk syrup system (the store pays the installer).
3. Working with the installer to identify sites for the tanks and CIP, as well as sources for CO₂, electricity and sanitary drainage.
4. Removing any installation site obstructions prior to the installation.
5. Participating in Hybrid Bulk training and mastering system operations.
6. Ordering bulk syrup deliveries.
7. Maintaining user's manuals, ASME pressure vessel certificates, and any other required documentation.
8. Obtaining any required permits, licenses, approvals or registrations.
9. Paying for the equipment, freight and installation.

10. Maintaining the equipment in good working condition.
11. Maintaining crew proficiency in good operation and use of the Hybrid Bulk Syrup System.

Required Tools and Supplies

Installation Tools

The following tools and other items may be required to perform a Hybrid Bulk System installation. These tools are not supplied by Chart.

1. Industrial Hammer Drill (used to drill holes into concrete or brick for mounting tanks, CIP, beverage tubing/lines, and drain line stand pipe).
2. 3/8" (9mm or 10mm) Carbide Drill Bit
3. Shop or Industrial Vacuum Cleaner or Other Cleaning Equipment
4. Level
5. Basic set of Beverage Installation and Shop Tools including:
 - Screw drivers (straight/flat and Phillips)
 - Tubing Cutter or Sharp Knife
 - Hammer
 - Wrenches or Spanners
 - Allen or Hex-Head Wrenches
 - Stop Watch or Watch with Seconds Indicator
 - Crimping Tool for crimping or tightening hose clamps (Oetikers)
 - Pliers
 - Wire Cutter and Stripper
 - Hand Saw (for plastic or copper for drain stand pipe)
6. Other tools as required

Required Supplies and Parts

The following supplies and parts are not supplied by Chart but will be required for a Hybrid Bulk System installation. The items shown below must be provided by the installer.

1. Extra Stepless Stainless Steel Hose Clamps (Oetikers) for 1/4" ID, 3/8" ID, and 1/2" ID beverage tubing.
2. Anchor Bolts for syrup tanks, bolt diameter 3/8" (9mm) x 3-3/4" long, e.g. Hilti Kwik Bolts or Red Head Trubolt Wedge Anchors.
3. Anchors or Screws for Mounting the clean-in-place panel (CIP) and hoses or clamps.

4. Conduit Straps or Brackets for securing tubing.
 5. Extra Wire Ties
 6. Flat Washers, with holes large enough for anchor bolts, for leveling and securing tanks.
 7. Locally Approved Electrical Wire Connectors or Tape.
 8. Teflon Tape (Recommended width of 3/8" to 3/4" / 9mm to 19mm).
 9. Plastic or Copper Tubing/Pipe/Elbow (with ID large enough to hold drain line, e.g. 2") for drain stand pipe.
 10. Solder or Adhesive/Cement to construct drain stand pipe.
 11. Some additional Stainless Steel Barbed Tees and Swivel Connectors may also be required for some installations.
 12. Plastic Mounting Blocks
 13. Low Pressure CO₂ Gas Regulators capable of reducing gas pressure down from a range of 90 psi to 300 psi to a final pressure range of 60 psi to 75 psi and maintaining a minimum flow rate of 250 scfh.
 14. Other parts and supplies as may be required.
4. The following guidelines apply to making joints or connections:
 - a. Threaded connections in contact with syrup should be sealed with an approved food grade O-ring or gasket.
 - b. Hose or tubing connected to a hose barb should be sealed using two stepless stainless steel hose clamps (Oetikers) or an approved ferrule of the correct diameter for the tubing.
 - c. Threaded connections not in contact with syrup should be sealed with Teflon tape.
 5. Many of the threaded connections in the bulk system are stainless steel to stainless steel (SS) joints. While many of these threaded parts have been electropolished, it is still possible for galling to occur. Use care when working with stainless steel threaded joints to prevent galling and lock-up.
 6. The following guidelines apply to the installation of beverage tubing:
 - a. Whenever possible, tubing should be bundled with cable ties when it is routed from one location to another within the store.
 - b. Tubing routed along walls or ceilings should be adequately supported with cable ties and/or mounting blocks.
 - c. Whenever possible, tubing should be routed vertically up walls and horizontally across ceilings rather than diagonally.
 - d. Avoid routing tubing over or close to heat sources.
 - e. Avoid securing tubing to electrical lines, conduit, junction boxes, or fixtures.
 - f. Avoid sharp bends in the tubing which might obstruct or slow the flow of syrup or compressed air or gas.

General Installation Guidelines

1. Syrup supply lines from the Bulk tanks to the dispensing valves should always be 3/8" ID or larger to minimize pressure drop.
2. Syrup lines should be kept as short as reasonably possible between all points within a beverage system to avoid undue pressure drop or flow restriction.
3. As a portion of the overall beverage system, Bulk tanks must be installed within the following limits in order to ensure proper operation of both the Bulk tank and the full beverage systems.

Lengths/Distances	Maximum
Tanks to Delivery Truck Parking Site	85 ft (25 m)
Tanks to Beverage Machine	75 ft (23 m)
Nearest Tank to Furthest Tank	12 ft (3.6 m)
Tanks to Sanitary Drain	25 ft (7.6 m)
CIP to Furthest Tank	20 ft (6.0 m)
24-Volt Transformer to CIP	50 ft (15 m)

Vertical Heights	Minimum	Maximum
Tanks to Beverage Machine		20 ft (6 m)
Floor to CIP	4 ft (1.2 m)	6 ft (1.8 m)
Floor to Top of Stand Pipe		3 ft (0.9 m)

7. At the completion of the installation, the install site and equipment should be cleaned to ensure an image of professionalism.
8. The five boroughs of New York City have Fire Department regulations that mandate unique equipment, installation, and certification. Do not attempt to order or install Hybrid Bulk syrup equipment without first consulting with Chart.
9. The Los Angeles and San Diego regions require PVC chases for beverage tubing. See special instructions in the Installation of Lines section.

10. The Hybrid Bulk syrup system normally requires the presence or installation of an approved and bulk syrup compatible (upgraded) bulk CO₂ system in order to perform a bulk syrup delivery. The exception to this rule is if the distribution center delivery truck provides compressed air or gas to perform the syrup deliveries. Ensure that a suitable supply of gas will be available to support the Hybrid Bulk syrup system.

11. The CO₂ gas supply to the CIP should be regulated through two low pressure gas regulators installed in series prior to entering the Bulk syrup tanks (in a normal installation the Bulk CO₂ tank provides one regulator and the CO₂ supply line regulator of the Hybrid system acts as the second). See the Installation of Lines section for more information.

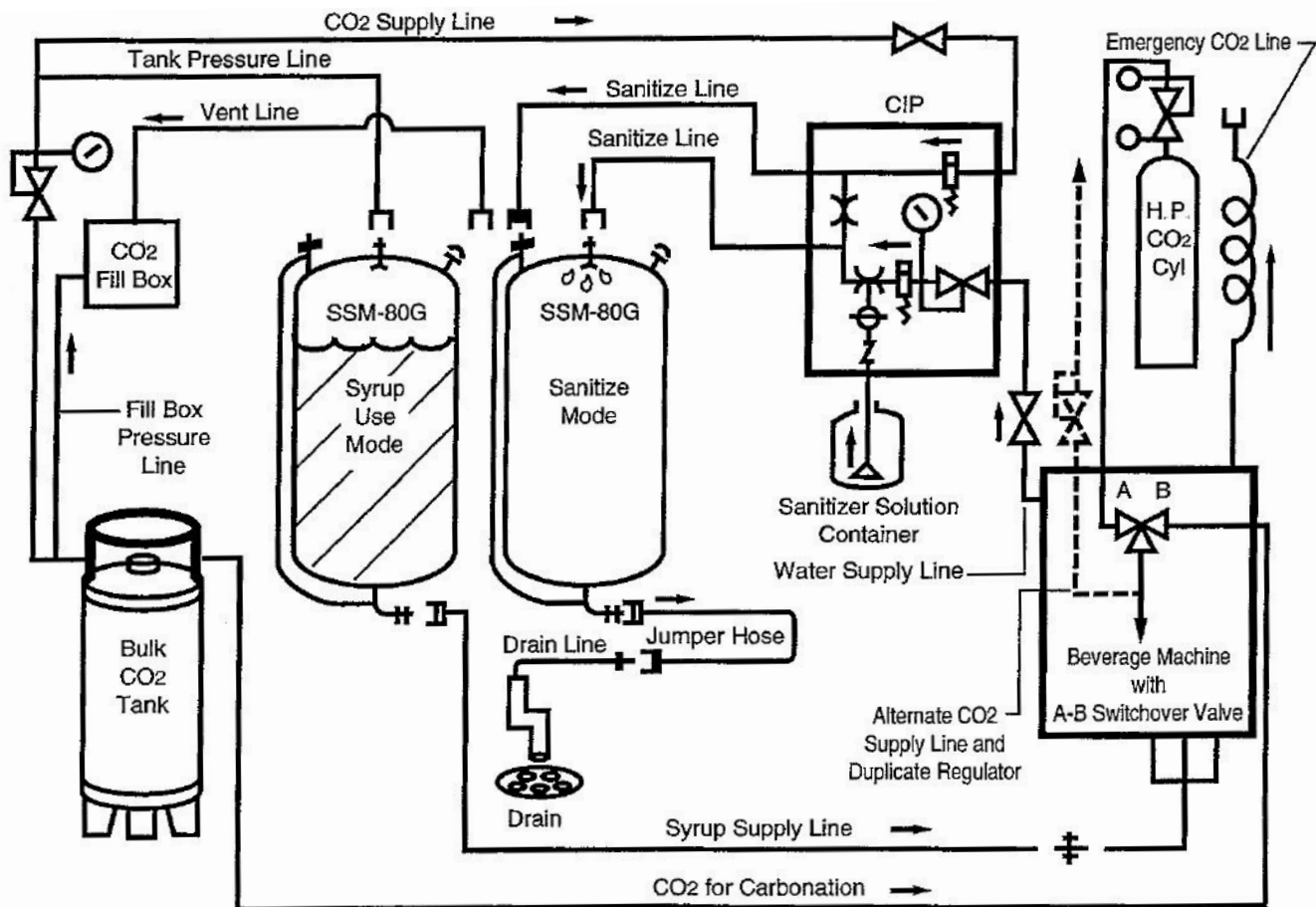

KEY

	2-Pin Connections		Regulator		Burst Disc
	1/2" Q.C. Connections		2-Pin Cross		Isolation Valve
	3/4" Q.C. Connections		Venturi		Solenoid Valve
	Switchover Valve		Orifice		Needle Valve

Figure 1 - Hybrid Bulk Syrup System

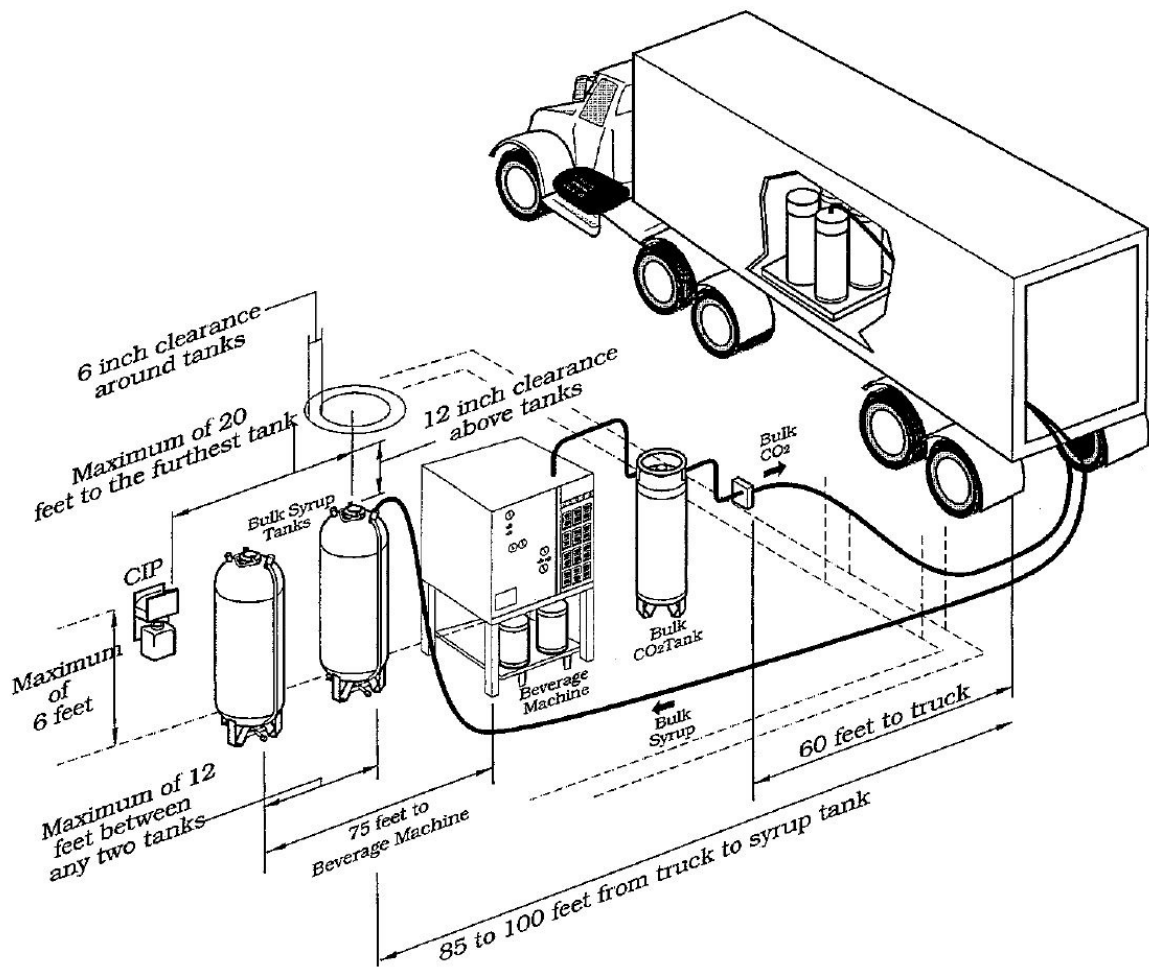



Figure 2 - Syrup System Distances

Locating Bulk Equipment

1. If a survey or blueprint of the store has recently been completed to select the best site for the bulk equipment, refer to the survey or blueprint for guidance, but also double check the details to ensure that no changes have occurred in the store and that no important facts have been overlooked. Consult with the store management to ensure the accuracy of information and the acceptance by the owner/management.
2. If no recent store survey exists for locating bulk equipment, conduct one with the assistance of the store management. It is strongly recommended that the survey be done before delivery of the equipment. Remember, it is the responsibility of the store management and the installer to properly site all Hybrid Bulk equipment.
3. When selecting the best location for the syrup tanks consider that the tanks must:
 - a. Be located inside the store.

- b. Be within 85 ft (25 m) of where the syrup delivery tank will be positioned when making a syrup delivery if they use a single 100 ft delivery hose.
- c. Be generally co-located with the beverage machine, in order to supply the syrup to the beverage machine and to have access to pressurized water and CO₂.
- d. Have access to potable water and a sanitary drain.
- e. Have adequate space for access and operations. The following are recommended space allowances:

Space Allowance	Size
Tank Diameter	22 in (560 mm)
Clearance Around Tank	6 in (150 mm)
Tank Height	66 in (1,676 mm)
Clearance Above Tank	12 in (305 mm)

 **Note:** The clearances are the minimum recommended allowances for easy cleaning and connection of hoses to the top of the tank. In some stores limitations on available space or local health, sanitation or safety codes may specify other standards which must be followed.

- f. Be sufficiently clear of aisles, doorways, floor drains, service panels, or utilities so no obstruction, hazard or violation of local codes exists.
 - g. Have easy access to the liquid level gauge and the syrup fittings on both the top and the bottom of the tank.
4. When selecting the best location for the clean-in-place (CIP) consider that the CIP must:
 - a. Be mounted vertically.
 - b. Be mounted at a height of approximately 4 ft to 6 ft (1.2 m to 1.8 m) above the floor.
 - c. Be easily accessible to store personnel in order to perform sanitize operations.
 - d. Be within 20 ft (6 m) of the furthest tank (usually the closer the CIP is to the tanks, the better it operates).
 - e. Be supplied with filtered potable water with a dynamic (flowing) pressure of not less than 40 psi (2.76 bar), but preferable at 60 to 90 psi (4.1 to 6.2 bar) dynamic water pressure.
 - f. Be supplied with clean CO₂ gas at 65 psi (4.5 bar).
 - g. Be supplied with electrical power rated at 24 volts AC from a step-down transformer located within 50 ft (15 m) of the CIP.
 5. Locate the Hybrid Bulk System where it has easy access for the syrup delivery, good lighting and good ventilation.



Caution! *Ventilation is especially important. CO₂ is heavier than air and does not support life.*

6. Ensure that the Bulk components are not too close to sources of heat that might cause heating of the syrup or affect the materials used in the system's parts.
7. Ensure that the Bulk system does not prevent access to other equipment, service panels, electrical junction boxes or panels, sewer or water traps or other access ports/panels/doors.
8. If the portable SSM-80G CB bulk syrup tanks are to be used, ensure there is adequate space to move and position the tanks; there are no steep slopes; the floors are smooth and unobstructed; and any elevators which must be used can support at least 1000 lbs (455 kg).

Installation of Syrup Tanks

1. Place the tanks in the proper position as indicated either on the survey form or as determined by the installer and store management's joint site selection (do not forget to allow the 6 in/ (150 mm) clearance around the tanks and 12 in (305 mm) above the tanks whenever possible.
2. Double check to ensure that adequate space and access exists for the other bulk components (CIP, etc.) and for surrounding equipment, storage, exits, aisles, etc.
3. Position the tanks so the Liquid Level Gauge is visible and all the fittings at the top and bottom of the tank are easily accessible and do not protrude into an aisle way or exit. Avoid having the drain fitting, liquid level gauge or legs pointing directly into the aisle.
4. Mark the location of the mounting holes of each leg on the floor.
5. Move the tanks and drill the holes for the anchor bolts.



Note: *Take care when drilling the holes in tile floors. Tile is brittle and can easily be cracked.*

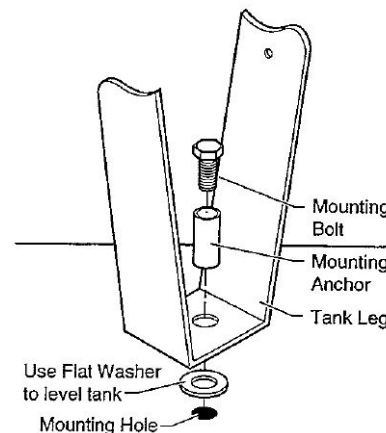

Figure 3 - Attaching legs to floor

6. Vacuum or clean the dust from the holes and inspect or test the holes to ensure they are deep enough for the anchor bolts.
7. Tap the anchors into the holes.
8. Set the tanks over the anchors.
9. Using a level, check to be sure the tanks are vertical (plumb). If necessary, use steel flat washers as shims to level the tanks. Failure to level tank will cause insufficient draining.
10. Bolt the tanks to the floor.

Installation of Clean-In-Place Panel

1. Hold the clean-in-place panel (CIP) against the wall in the selected location. Use a level to ensure the panel is vertical or plumb and mark the location of the four mounting holes.
2. Remove the CIP and drill the four holes for the anchors or screws. Take care if drilling in tile as it cracks easily.
3. Tap the anchors, if used, into the holes.
4. Install screws into the upper two holes or anchors and tighten halfway.
5. Hang the CIP on the first two screws and double check the position of the other two screws and the level of the CIP. If everything is satisfactory, tighten the first mounting screws.
6. Install and tighten the remaining mounting screws.
7. Remove the screws from the front panel of the CIP cabinet, being careful not to lose them. Carefully lower the front panel to expose the internal operating components.
8. Remove the curved top panel of the CIP cabinet by gently applying pressure to the panel to dislodge it from the slots in the side of the cabinet.
9. Lift out the electrical wire and unroll it, being careful not to damage the wire's connections with the CIP and solenoids.
10. Measure the distance from the nearest available or selected 110-volt electrical outlet to the CIP to ensure that the 50 foot wire will meet the needs. If not, another outlet must be selected or a new one installed by an electrician.
11. Route the CIP wire to the selected outlet so that it is safely out of the way and firmly secured to walls, ceilings or other supports.
12. Cut off any excess wire, strip the insulation off the ends exposing about 1/2" of wire, and connect the wires to the 24-volt screw terminals located on the transformer. Use the center terminals on the transformer marked "LOAD" (polarity is not a concern; connect either wire to either terminal).
13. Plug the transformer into the outlet, following the installation instructions, and secure the transformer into the outlet using the connecting screw which goes into the electrical outlet plate.
14. Attach the sanitize solution container to the mounting posts located near the bottom of the CIP, being sure to position the sanitizer inlet tube inside the open container.

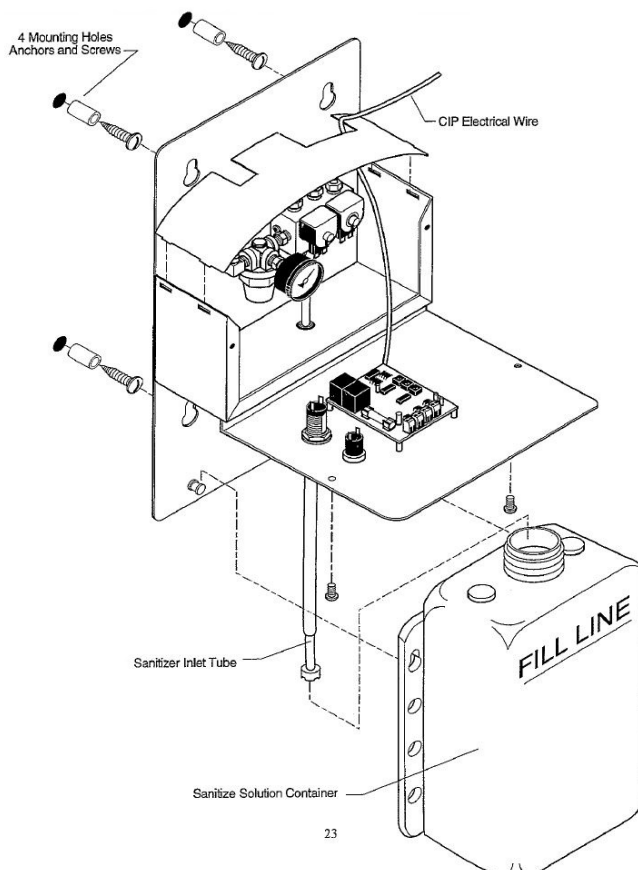

Figure 4 - Installation of CIP Panel

Note: Instructions for connecting the CO₂ supply, water supply, and sanitation line will be described later.

Installation of Lines

A total of 8 to 10 lines (excluding the jumper hose which requires no installation or assembly) must be installed to connect all the components of the bulk and beverage systems together. The beverage tubing is supplied in three different sizes (ID) and colors. The color coding simplifies both installation and store operations. Installation of the wrong color lines may lead to operational problems later.

The following is a list of all the possible interconnecting lines. The installation of some of these lines may cause an interruption of the store's beverage service. These lines have been marked with an asterisk (*). If this portion of the installation is being performed during normal store hours, care should be taken to minimize interruption and times to cause the least interference.

Line	Color	ID Size	From	To
CO ₂ Supply*	Red	1/4"	Bulk CO ₂ Tank or Beverage Machine	CIP
Tank Pressure*	Red	1/4"	CO ₂ Supply Line	Tanks
Sanitize - Spray Head	Red	3/8"	CIP	Tanks
Sanitize - Fill Fitting	Blue	1/4"	CIP	Tanks
Water Supply Line*	Red	3/8"	Beverage Machine	CIP
Vent**	Green	1/4"	Tanks	Outdoors
Drain Line	Blue	1/2"	Jumper Hose/Tanks	Drain
Syrup Supply **	Red	1/2" & 3/8"	Tanks	Beverage Machine
Emergency CO ₂ *	Red	1/4"	Beverage Machine	Tanks
Fill Box Pressure ***	Red	1/4"	Bulk CO ₂ Tank	CO ₂ Fill Box

*The installation of these lines may cause an interruption of the store's beverage service.

**In stores where syrup is being off-loaded from the syrup delivery tank using CO₂ gas, and especially if the store's syrup tanks are located in a basement or poorly ventilated room, then it is strongly recommended that the vent line be routed outdoors. If the store has an approved bulk CO₂ tank the syrup vent line should be routed to the outdoor CO₂ fill box.

The 1/2" main syrup line splits into either 2 or 3 smaller 3/8" secondary syrup supply lines. Depending upon the number of filters to be supplied with syrup.

This line is used to supply CO₂ pressure for the delivery of bulk syrup and can only be installed and used if there is an approved bulk CO₂ tank and fill box.

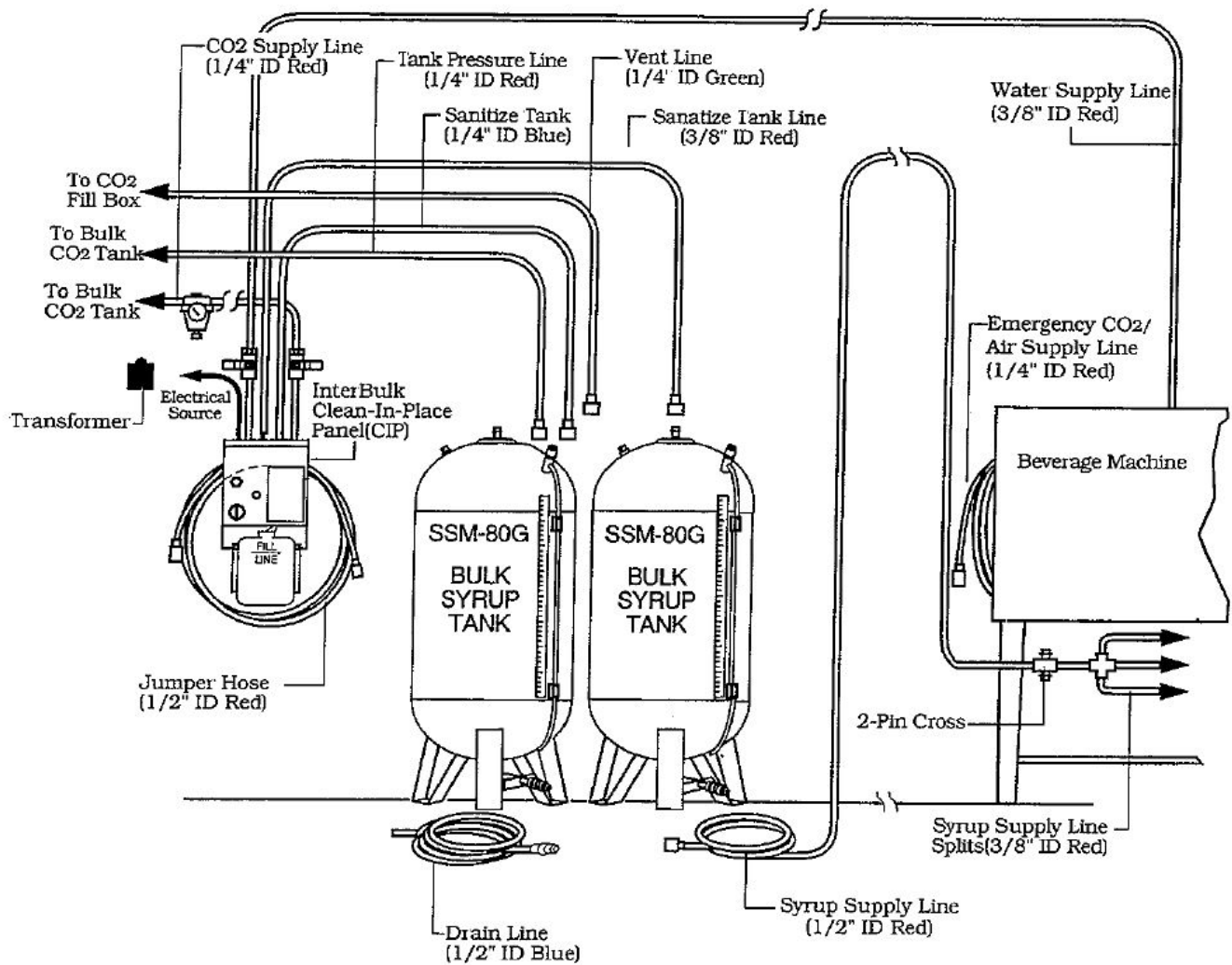

Figure 5 - Diagram of Line Installation



Caution! CO₂ is heavier than air and does not support life.



Note: All lines which are permanently mounted or installed must be bundled neatly and run level.

Hose clamps should be matched with the following tubing:

Clamp No.	Tubing
# 133	1/4" ID Blue and Green
# 140	1/4" ID Red
# 170	3/8" ID Red
# 198	1/2" ID Blue



Note: See special instructions at the end of this section for installations in Los Angeles and San Diego markets.



Note: Bulk equipment and installations in the five boroughs of New York City must meet special conditions and standards set by the NYC Fire Department; consult with the NYCFD or Chart before ordering or installing in NYC.

CO₂ Supply Line From Bulk CO₂ Tank to CIP

Not all stores will be equipped with an approved bulk CO₂ tank or CO₂ tank upgraded for bulk syrup. In the latter case the CO₂ tank must be upgraded for bulk syrup in accordance with upgrade kit procedures. In the absence of an approved bulk CO₂ system, first ensure the store will be able to have its bulk syrup deliveries done using compressed gas/air supplied by the distribution center (if this is not the case, then the store must have bulk CO₂ in order to make bulk syrup deliveries); and second, follow the "Alternative Methods" listed at the end of this section.

1. Cut a length of 1/4" red line tubing sufficient to run from the syrup supply pressure regulator outlet on the bulk CO₂ tank to the CIP (leave enough slack for adjustments and mounting along the walls and ceiling).
2. Slip two hose clamps over the CO₂ tank end of tubing and secure to 1/4" barb on tank.

3. Remove brass cap from tee (downstream of syrup supply regulator) on bulk CO₂ tank and connect tubing to the tee on CO₂ tank (ensure isolation or shut-off valve to syrup regulator is closed before removing cap and remove cap carefully in case there is residual pressure).
4. Assemble the 1/4" ID CO₂ isolation valve to the two 1/4" hose barbs using Teflon tape on the threads.
5. Slip two hose clamps over the CIP end of the tubing and secure the tubing to the 1/4" barb (marked "C") on the upper right side of the manifold block in the CIP.
6. Select a convenient location in the CO₂ supply line near the CIP to insert the isolation valve and cut the line.
7. After placing double hose clamps on both sides of the line, insert the isolation valve and secure it with the clamps.
8. Assemble the CO₂ pressure regulator with the 1/4" hose barbs using Teflon tape to seal the threads.
9. Select a convenient location in the CO₂ supply line near the bulk CO₂ tank or other CO₂ source to insert the CO₂ regulator and cut the line.
10. After placing double hose clamps on both sides of the line, insert the CO₂ regulator into the CO₂ supply line and secure it with the clamps.
11. Select a convenient location between the CO₂ regulator and the CO₂ isolation valve, usually close to the regulator, to insert the 1/4" x 1/4" x 1/4" barbed tee in the CO₂ supply line and cut the line.
12. After placing the hose clamps on the line, insert the tee into the line and secure it with the clamps.

Alternative Methods for Installing CO₂ Supply Line to Non-Bulk CO₂ Gas Source

If the store does not have an approved and bulk syrup compatible bulk CO₂ tank **and** bulk syrup deliveries will be made using a gas source other than the store's bulk CO₂ tank, then the CO₂ for the CIP must come from the CO₂ supply in the beverage machine, and not from a bulk CO₂ tank.



Note: When using one of the alternative installations Chart strongly recommends the installation of a second low pressure CO₂ regulator in the CO₂ supply line prior to the regulator supplied in the installation kit. The regulator should be set at 65 to 75 psi, be CO₂ compatible, and be capable of a flow rate of at least 7 scfh. Never use a high pressure or 2-stage regulator. Failure to use a second regulator in series may

result in premature or repeated bursting of the syrup tanks' rupture discs (because this regulator is not required for all installations, it is not supplied with the hybrid syrup installation kit).

Alternate No. 1

- Perform steps 1 - 4 between the CIP and the beverage machine.
- Downstream of the 90 psi CO₂ regulator and the A-B Switchover Valve in the beverage machine, if the CO₂ line is standard beverage tubing, shut off CO₂ gas flow and depressurize the CO₂ tubing.
- Cut the tubing (CO₂ line), leaving space on either side of the cut to splice in a 1/4" barbed tee.
- Slip double hose clamps on either side of the cut, insert a 1/4" barbed tee, and secure the tee.
- After placing hose clamps on the CO₂ supply line, attach it to the open leg of the 1/4" barb and secure it.
- Complete steps 5 - 12.

Alternate No. 2A

- Perform steps 1 - 4 between the CIP and the beverage machine.
- Downstream of the 90 psi CO₂ regulator and the A-B Switchover Valve in the beverage machine, if the CO₂ line is semi-rigid tubing (not beverage tubing), shut off CO₂ gas flow and depressurize the CO₂ line.
- In some beverage machine models, remove the compression elbow from the back of the A-B Switchover Valve and replace it with a tee (3/8" ID compression x 1/4" MPT x 1/4" male flare). Attach CO₂ supply line to the 1/4" hose barb and 1/4" flared swivel nut. Connect line/nut to 1/4" male flare on tee and reconnect rigid tubing into compression joint.
- Complete steps 5 - 12.

Alternate No. 2B

- Perform steps 1 - 4 between the CIP and the beverage machine.
- Downstream of the 90 psi CO₂ regulator and the A-B Switchover Valve in the beverage machine, if the CO₂ line is semi-rigid tubing (not beverage tubing), shut off CO₂ gas flow and depressurize the CO₂ line.

- In some machine models, disconnect the pressure sensor switch from the CO₂ line. Insert a tee (1/4" male flare x 1/4" male flare x 1/4" female flare) between the CO₂ line and pressure sensor switch. Attach CO₂ supply line to 1/4" hose barb and 1/4" flared swivel nut. Connect line/nut to open leg of 1/4" male flare on tee.
- Complete steps 5 - 12.

Tank Pressure Line (CO₂) from CO₂ Source to Bulk Tanks

1. Cut a length of 1/4" red line tubing sufficient to run from the recently inserted 1/4" tee in the CO₂ supply line to the furthest syrup tank. Leave enough slack for mounting and so the line can reach all tanks.
2. After placing hose clamps on the pressure line tubing attach it to the open leg of the 1/4" barb in the CO₂ supply line and secure it.
3. At the tank end, after placing hose clamps, attach a female 2-pin beverage connector.
4. Attach red tubing label marked "Tank Pressure" approximately 6" from the 2-pin connector and secure with a small cable tie.

Sanitize Line (Spray Head) from CIP to Bulk Syrup Tanks

1. Cut a length of 3/8" red tubing sufficient to run from the CIP to the furthest syrup tank. Leave enough slack for proper mounting and so the line can easily reach all tanks.
2. At the CIP, after positioning two hose clamps, attach the line to the 3/8" barb (marked "SH") on the top of CIP manifold block and secure it.
3. At the tank end, after positioning hose clamps, attach the female 2-pin beverage connector with the 3/8" barb to the 3/8" sanitize line and secure it.
4. Attach a red tubing label marked "Sanitize Tank" approximately 6" from the 2-pin connector and secure with a small cable tie.

Sanitize Line (Fill Fitting) from CIP to Bulk Syrup Tanks

1. Cut a length of 1/4" blue tubing sufficient to run from the CIP to the furthest syrup tank. Leave enough slack for proper mounting and so the line can easily reach all tanks.
2. At the CIP, after positioning two hose clamps, attach the line to the 1/4" barb (marked "F") on the top of the CIP manifold black and secure it.
3. Assemble the 3-piece 3/4" brass sanitize quick connect coupling using Teflon tape to seal the threads. The 1/4" barb connector will screw into the 1/4" FPT x 3/4" MPT hex bushing which screws into the 3/4" FPT end of the quick coupling. Attach the 3/4" black rubber plug to the assembled coupling.
4. At the tank end, after placing hose clamps on the 1/4" line, attach the 3/4" brass sanitized coupling to the line and secure it.
5. Attach a blue tubing label marked "Sanitize Line" to the 1/4" sanitize line approximately 6" from the 3/4" brass coupling and secure with a small cable tie.

Water Supply Line from Beverage Machine to CIP

1. Route a 3/8" red line from the CIP to the area of the water boost pump and filter on the beverage machine. Leave enough slack for proper mounting and attachment at both ends.
2. After placing hose clamps on the line, attach the water supply line to the 3/8" OD hose barbs sealing the threads with Teflon tape.
3. Select a convenient location in the water supply line to insert the isolation valve and cut the line.
4. After placing hose clamps on the line, insert the isolation valve barbs into the line and secure them.
5. Close the water isolation valve until the system is fully installed and ready for testing.
6. Turn off the water supply to the beverage machine.
7. Carefully cut the beverage machine's water line at the convenient point after the boost pump and the water filter.



Caution! *The water line will still be pressurized and have some water remaining in it when the line is cut.*

8. Insert and secure the appropriate tee fitted with a 3/8" hose barb into the beverage machine's water line. Two tees are supplied: a 3/8" x 3/8" x 3/8" barbed tee for use with 3/8" ID beverage tubing lines and a 3-piece 3/4" compression style assembly for use with 3/4" OD hard plastic tubing lines. The assembly includes a 3/4" x 3/4" MPT x 3/4" compression tee, a 3/4" FPT x 1/2" MPT brass reducer / adapter, and 1/2" FPT x 3/8" brass barb. Use Teflon tape to seal the threads on the assembly.
9. After positioning hose clamps, attach the 3/8" water supply line to the 3/8" barb on the tee and secure it.
10. Turn on the water to the beverage machine and inspect for leaks.

Vent Line from Bulk Syrup Tanks to Outdoors

1. Determine if vent line can be terminated outdoors, either at an approved CO₂ fill box or at an alternative site using stainless steel vent tube (or other method acceptable to the store management).



Warning! *CO₂ gas, when used in the delivery of bulk syrup, if not vented outside the building can result in excess CO₂ accumulation and create an oxygen deficient atmosphere. Exposure to excess CO₂ can produce headaches, nausea and vision difficulties, and could result in unconsciousness and serious or fatal injury.*

2. Cut a length of 1/4" green tubing sufficient to run from the furthest tank to outside the CO₂ fill box or the location of the vent tube. Leave enough slack for proper mounting and so the line can reach all syrup tanks.
3. At the CO₂ fill box, after positioning hose clamps, attach green vent line to 1/4" vent elbow in the back of the fill box. Do NOT attach vent line to 1/4" barb connected to the back of the male 2-pin beverage connector located inside the fill box! For stores with the large flush-mounted fill box, run vent line into back of fill box and into tube holder located in the bottom corner of the box. Secure vent line with cable ties.
4. If stainless steel vent tube is used, install the vent tube to the outdoors, caulk or seal the tube in place and attach vent line to vent tube using hose clamps.
5. At tank end, after positioning hose clamps, attach female 2-pin beverage connector.

- Attach green and yellow tubing label marked “Tank Vent” or “Vent” approximately 6 inches from 2-pin connector and secure with small cable tie.

Drain Line from Bulk Syrup Tanks to Sanitary Floor Drain

- Cut a length of 1/2” beverage tubing sufficient to run from the furthest syrup tank to the floor drain (this line is NOT to be permanently mounted, but some slack should be allowed for ease of use).
- Assemble the 3/4” brass quick connect nipple to the 1/2” brass barbed connector using Teflon tape on the threads.
- After positioning the hose clamps, attach the drain line to the 1/2” barb and secure.
- Attach the tubing label marked “Drain” on the line approximately 6 inches from the nipple and secure with a small cable tie.

Syrup Supply Line from Syrup Tanks to Beverage Machine



Note: Syrup Supply Line is supplied with the installation kit and comes partially assembled, including 85 ft of 1/2” red line tubing and a 1/2” SS quick connect coupling. The completed line after full assembly includes a double 2-pin cross (for emergency syrup supply) and either a barbed tee or a cross to split the main line into two or three smaller 3/8” ID lines to feed two or three syrup filters, as needed.

- Connect the quick connect coupler of the syrup supply line to the furthest syrup tank.
- Route the line along the floor, wall or ceiling to the syrup connections (filters) on the beverage machine. Leave enough slack to properly mount the line and so the line can be connected easily to all tanks.
- Route the line either under the beverage machine above the 5-gal tray or along the lower back of the beverage machine (the line’s route should allow a 5-gal to be connected to the special double 2-pin cross in the supply line using a standard 5-gal jumper hose).
- Cut the line to the required length.
- After positioning hose clamps, attach either the stainless steel cross (1/2” x 3/8” x 3/8” x 3/8”) or the stainless

steel tee (3/8” x 1/2” x 3/8”) depending upon the number of syrup filters to be supplied.

- Cut two or three lengths of 3/8” red beverage tubing long enough to run from the cross (or the tee) to the syrup connections on the filters.
- After positioning hose clamps, attach each of the 3/8” lines to the 3/8” barbs on the cross (or tee).
- At an accessible point along the main 1/2” line and near the 5-gal tray, cut the 1/2” line in two, position hose clamps on both sides of the cut and attach the double 2-pin cross (the 2-pin cross is the emergency point for 5-gals).
- If store is already operating with 5-gals, then depressurize and disconnect existing syrup lines from syrup filters and, after positioning hose clamps on each secondary 3/8” bulk syrup supply lines, attach 3/8” lines to syrup filters. (To restart syrup supply from 5-gals, connect 5-gal to one of the 2-pin connectors on the 2-pin cross using the standard short 5-gal jumper hoses and then reconnect air/CO₂ pressure to 5-gal. If two or more 5-gals are to be connected to the cross, connect them in series using jumpers. Finally, observe the syrup supply line, when it is completely full of syrup, disconnect the line from the bulk syrup tank).
- If the store or beverage machine is not yet in operation, then after positioning hose clamps on each secondary 3/8” line, attach the lines to the syrup filters (to temporarily use 5-gals to supply syrup see step 9 above).
- Attach the red tubing label marked “Syrup Supply” approximately 6” from the 1/2” stainless steel quick coupler.

Emergency CO₂ (or Air) Line from Beverage Machine to Bulk Syrup Tanks



Note: Emergency CO₂ line provides a means of pressurizing the bulk syrup tank in the unlikely event the bulk CO₂ supply is interrupted. This line can be installed to supply either air (the most commonly used option) or CO₂.



Warning! The emergency line must be connected to a 60 psi (medium pressure) regulator or gas source. NEVER connect it to a 90 psi regulator or air pump source as this will damage the syrup tanks.

1. Cut a length of 1/4" red line tubing long enough to run from the beverage machine (or other gas source) to the furthest syrup tank.
2. At the tank end, after positioning hose clamps, attach a female 2-pin beverage connector.
3. Attach the tubing label marked "Emergency CO₂" and secure with a small cable tie.
4. At the beverage machine, splice the line into a 60 psi air or CO₂ line or manifold.
5. Coil line up and secure it behind the beverage machine with a cable tie.

Fill Box Pressure Line from Bulk CO₂ Tank to CO₂ Fill Box



Note: If bulk syrup is to be delivered using CO₂ from an approved and syrup compatible/upgraded CO₂ tank and if the male 2-pin connector in the CO₂ fill box has not been connected to the CO₂ tank during the original bulk CO₂ installation, then the bulk syrup installer should make this connection.

1. Cut a length of 1/4" red line tubing sufficient to run from the syrup gas supply regulator on the bulk CO₂ tank to the CO₂ fill box.
2. At the CO₂ tank, ensure the CO₂ supply is turned off and the circuit is depressurized, remove the plug or cap from the unused port on the tee downstream of the 60 psi or 65 psi syrup regulator and then attach the line to the port.
3. At the back of the CO₂ fill box, after positioning the hose clamps, attach the line to the 1/4" barb on the back of the male 2-pin beverage connector located inside the fill box.
4. Secure the line with cable ties.

Final Line Installation Steps

1. Neatly bundle all lines where they run together using cable ties.
2. Using mounting blocks, cable ties, and other attachment devices securely mount all lines except the drain line, emergency CO₂ line and jumper hose to the walls, ceiling, beams, etc., so no sagging or loops exist (do NOT attach lines to electrical lines/conduit, refrigerator walls or lines, sewage pipes, etc.).
3. Turn on CO₂ gas supply to the CIP, tank pressure line and fill box.
4. Turn on the water supply to the CIP.
5. Check for leaks, loose hose clamps, missing labels, closed valves, and static water pressure to the CIP.

Special Instructions for Los Angeles and San Diego Regions

1. All beverage tubing/lines that run along a wall must be run through a PVC chase with both ends sealed using either silicon or foam.
2. Lines run up to and above a drop ceiling must have the PVC chase extended through or above the ceiling. The chase must be sealed at both ends and the hole in the ceiling tile must be sealed around the chase with silicon (the lines above the ceiling need not be enclosed in a chase).
3. All PVC chases should be mounted on KWIK Blocks with 1/2" clearance to the wall.

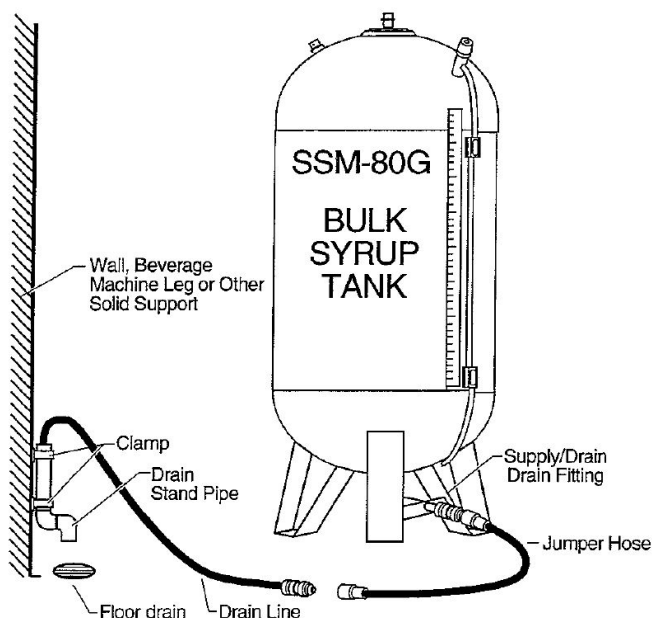

Figure 6 - Drain Line Stand Pipe

1. Fabricate a stand pipe using either rigid plastic or copper pipe. The pipe and elbows should be large enough in internal diameter (3/4" or larger) to receive the end of the drain line.
2. Mount the stand pipe either to a wall, the beverage machine or other solid support.
3. Leave a 2" to 4" (50 mm to 100 mm) air gap between the bottom of the pipe and the drain.



Note: If the floor drain is in a hard to reach location (e.g. behind or under the beverage machine) fabricate the stand pipe so that the vertical end of the pipe into which the drain line is inserted is routed to an easily accessible location.

Installation of Labels

1. The following labels should be installed on the CIP:
 - a. Label, CIP Operations Guide Item 26
2. The following labels should be installed on the lines (tubing):
 - a. Labels, Sanitize Tank (2 lines) Item 50
 - b. Label, Tank Pressure Item 7a
 - c. Label, Vent Item 11a
 - d. Label, Drain Item 10c
 - e. Label, Syrup Supply Item 6d
 - f. Label, Emergency CO₂ Supply Item 51a
3. The following labels should be installed on the bulk syrup tanks:
 - a. Label, "1" Item 1a
 - b. Label, "2" Item 1b
 - c. Label, "3" (if req'd)

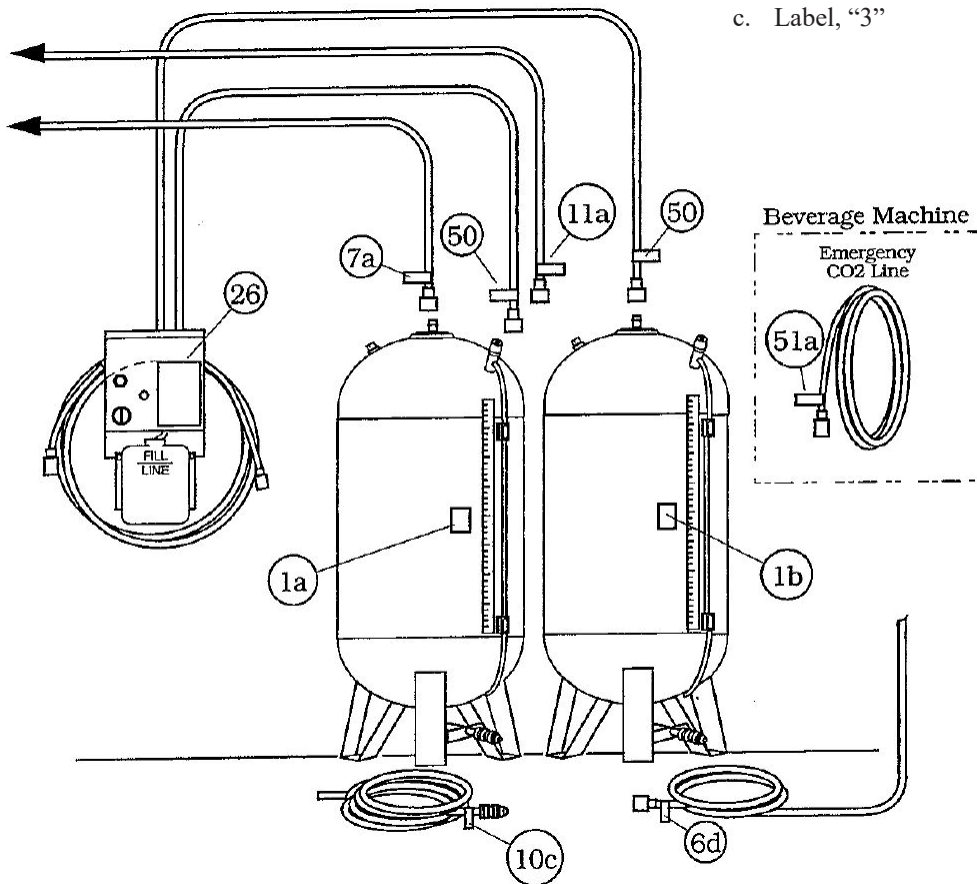

Figure 7 - Label Installation

System Testing and Operation

System Inspection and Testing



Note: After completing the inspection and testing it is suggested you review the inspection results with the store management.

1. Verify the water and CO₂ supplies to the beverage machine and CIP are turned on.
2. If 5-gals are being used temporarily to supply syrup to the beverage machine, verify the syrup supply line is disconnected from the Bulk syrup tanks.
3. Inspect bulk syrup tanks to ensure they are:
 - a. Properly positioned and level,
 - b. Secured to the floor with anchors,
 - c. Not obstructing aisles, exits, utilities, etc.,
 - d. Labeled properly.
4. Inspect CIP to ensure it is:
 - a. Secured and level,
 - b. Within reach of the furthest tank using the sanitize lines,
 - c. Labeled properly,
 - d. Connected to the 24-volt transformer,
 - e. Easily accessible to store personnel.
5. Inspect lines to ensure they are:
 - a. Properly installed and routed,
 - b. Correctly labeled,
 - c. Neatly bundled and secured to walls using cable ties and mounting blocks to prevent sagging,
 - d. 5-gal emergency cross is installed in syrup supply line,
 - e. Emergency CO₂ line installed, labeled and secured.
6. Inspect drain line stand pipe to ensure it is:
 - a. Accessible to store personnel,
 - b. Properly installed with at least a 2" air gap.
7. Inspect 24-volt transformer and electrical line to ensure they are secured.
8. Pressurize entire system (tanks, CIP, 10-gal and lines) and check for leaks using a liquid soap solution.
9. Ensure a store operating manual and one ASME certificate (Form U-1A) for each syrup tank are available for presentation to the store management.
10. Verify CO₂ pressures for:
 - a. Approved Bulk CO₂ Tank:
 - Tank pressure at least 125 psi
 - Pressure to beverage machine at least 90 psi (factory set at 90 psi)
 - Pressure to CIP 65 psi (\pm 5 psi)
 - b. High Pressure CO₂ Cylinders:
 - Cylinder pressure at least 400 psi
 - Pressure to beverage machine at least 90 psi
 - Pressure from beverage machine to CIP between 60 psi and 75 psi (never more than 80 psi as this may cause damage to components of the bulk syrup system)
11. Perform a sanitize operation using one of the empty bulk syrup tanks, following the procedures outlined in store's user manual. Check the following:
 - a. Open the front panel of the CIP cabinet and verify that the static water pressure (pressure when the water is not flowing) is at least 40 psi, as indicated on the water pressure gauge.
 - b. Using a stopwatch or a watch with a seconds indicator, check the time for the first three cycles of the sanitation procedure (the last three cycles are repetitions of the first three cycles).
 - Rinse (Cycle #1)
4 minutes (\pm 10 seconds)
 - CO₂ Purge (Cycle #2)
3/4 minute (\pm 10 seconds)
 - Drain / Idle (Cycle #3)
6.5 minutes (\pm 15 seconds)
 - c. Check to ensure the timer light on the CIP is flashing during the sanitize procedure.

- d. Verify that the dynamic water pressure (pressure when the water is flowing) during either the rinse or sanitize cycles is about 34 to 40 psi on the water pressure gauge. If satisfactory, close and secure the front panel of the CIP.
 - e. Verify that at the completion of the sanitize procedure about 200 ml (1/4" to 1") of sanitize solution remains in the sanitize solution container.
 - f. Verify that the manual purge button operates properly at the end of the sanitation process.
 - g. Inspect for water, CO₂ or air leaks.
12. Ensure the installation site has been cleaned and no trash remains undisposed in the store.

Operating Instructions

1. Present the ASME certificates (Form U-1A) to the store management and advise them that they must keep these documents as required by code (duplicate copies are available from Chart).
2. Present the User's/Equipment Manual to the store manager.
3. Verbally explain the Hybrid Bulk System and point out its components and lines.
4. Demonstrate the sanitizing procedure to the store manager and his/her staff.
 - a. Refer to the User's/Equipment Manual to highlight the steps.
 - b. Have the manager or store staff sanitize any remaining tanks.
5. If syrup is being temporarily supplied from 5-gals explain when and how the system can be converted back to bulk syrup supply by disconnecting the 5-gals and connecting the syrup supply line to a full bulk syrup tank.
6. Have the store manager sign the completed warranty card. Leave second copy with the store and mail first copy to Chart.
7. Invoice store for installation.



Parts

Parts Lists

The following components are part of a Hybrid Bulk System:

- Two or more: SSM-80G (or SSM-80G CB) Bulk Syrup Tanks PN 10667511 (or 10667503)
- One Hybrid Bulk Syrup Installation Kit with: InterBulk CIP and Hybrid Label Kit PN 10667431
- One Hybrid Bulk Syrup Tubing Kit PN 10667466

Bulk Syrup Tank

The following parts are included with each Bulk Syrup Tank (PN 10667511 or 10667503)

PN	Description	Qty	Function
10718201	User's / Equipment Manual	1	Provides user information
10543332	Sanitation Placard, Plastic	1	Record of sanitation procedures
Form U-1A	ASME Certificate	1	Certifies tank's compliance with ASME Pressure vessel codes

Hybrid Bulk Installation Kit

The following parts are included in the Hybrid Bulk Installation Kit (PN 10667431):

PN	Description	Qty	Function	Item
97-2310-9	InterBulk Clean-In-Place Panel (CIP)	1	Sanitizes syrup tanks between refills	2
46-1389-R	Transformer, 110V to 24V	1	Supplies 24V power to CIP	4
97-1057-9	Syrup Jumper Hose 1/2" x 15', with 3/4" SS F coupler & 1/2" SS F coupler	1	Interconnects tanks for syrup supply & connects tank to CIP for sanitizing	5
97-1968-9	Syrup Supply Hose, 1/2" x 85', with 1/2" SS F coupler	1	Connects tanks to beverage machine for supply of syrup	6
10648353	3/4" Quick Connect Nipple, brass with 3/4" FPT	1	Connects drain line to jumper hose for sanitizing	10a
10648345	1/2" Hose Barb, brass, 3/4" MPT x 1/2" barb	1	Connects 3/4" drain nipple to 1/2" line	10b
16-1150-9	1/2" SS Barbed Cross with 2 male 2-pin beverage connectors	1	Connects into 1/2" syrup supply hose for emergency use of 5-gals	6a
16-1142-1	SS Barbed Cross, 1/2" x 3/8" x 3/8" x 3/8"	1	Splits 1/2" syrup supply hose for 3 lines to beverage machine	6b
16-1168-1	SS Barbed Tee, 3/8" x 1/2" x 3/8"	1	Splits 1/2" syrup supply hose for 2 lines to beverage machine	6c
65-1170-6	Female 2-Pin Beverage Connectors with 1/4" barb	3	Connectors for pressure line, vent line and emergency CO ₂ line	37
65-1177-2	3/4" Quick Coupler, brass, 3/4" coupler x 3/4" FPT	1	Couples 1/4" sanitize line to syrup fill / sanitize fitting	9a
39-1160-6	3/4" Dust Plug, rubber	1	Protects 3/4" brass and SS quick couplers	38
12-1004-2	Hex Bushing, brass, 3/4" MPT x 1/4" FPT	1	Joins PN 65-1177-2 and 16-1132-2	9b
17-1697-2	Isolation Valve, 1/4"	1	Shuts off CO ₂ supply line to CIP	39a
21-1161-5	Pressure Regulator, low pressure	1	Reduces CO ₂ pressure to CIP and tanks to 60 psi	39b

Hybrid Bulk Installation Kit (continued)

PN	Description	Qty	Function	Item
20-1246-9	Pressure Gauge	1	Shows CO ₂ pressure to tanks and CIP	39c
16-1132-2	1/4" Hose Barb, 1/4" MPT x 1/4" barb	5	Use with PNs 12-1004-2, 17-1697-2 and 21-1161-5	40
17-1492-2	Isolation Valve 3/8"	1	Shuts off water supply line to CIP	41a
16-1216-2	3/8" Hose Barb, 1/4" MPT x 3/8"	2	Use with PN 17-1492-2	41b
85-0599-1	SS Vent Tube, 1/4" OD x 14' long	1	Alternative exterior vent in absence of CO ₂ fill box	42
16-1161-2	1/4" Barbed Tee, 1/4" x 1/4" x 1/4"	2	Splits CO ₂ supply line to CIP and tanks <u>and</u> connects CO ₂ supply line into 1/4" 90 psi CO ₂ line in some beverage machines in absence of Bulk CO ₂ (option 1)	39d
10-1406-2	Tee, 3/8" ID compression x 1/4" MPT x 1/4" M flare	1	Connects CO ₂ line to CIP into some beverage machines at back of A-B switch-over valve (option 2). Use with PN 16-1148-1 and 16-1147-1	39e
11-1157-2	Tee, 1/4" F flare swivel x 1/4" M flare x 1/4" M flare	1	Connects CO ₂ line to CIP into some beverage machines at pressure sensor switch (option 3). Use with PN 16-1148-1 and 16-1147-1	39f
16-1147-1	Swivel Nut, 1/4" F flare, SS	1	Use with PN 16-1148-1 and 11-1157-2 or 10-1406-2 to tap into CO ₂ supply	39g
16-1148-1	Flared Hose Barb, 1/4" x F flare, SS	1	Use with PN 16-1147-1 and 11-1157-2 or 10-1406-2 to tap into CO ₂ supply	39h
16-1154-1	Hose Splicer, 1/4" barbed, SS	1	Splices 1/4" emergency CO ₂ line into 60 psi air line on beverage machine or 1/4" vent line into drop line from CO ₂ fill box	43
16-1155-2	3/8" Barbed Tee, 3/8" x 3/8" x 3/8"	1	Connects water supply line into 3/8" tubing in beverage machine (option 1)	41c
10528327	Compression Tee, brass, 3/4" comp x 3/4" MPT x 3/4" comp	1	Connects water supply line into 3/4" plastic line in beverage machine (option 2)	41d
10528335	Reducer Adapter, brass, 3/4" FPT x 1/2" MPT	1	Use with PN 10528327 and 10528343	41e
10528343	3/8" Barb, brass, 1/2" FPT x 3/8"	1	Use with PN 10528327 and 10528335	41f
65-1230-6	2-Pin Beverage Coupling with 3/8" Barb	1	Coupling for 3/8" sanitize line	8a
34-1132-1	Hose Clamp, stepless, 1/4" ID (#133)	6	Secures 1/4" beverage tubing	44
34-1133-1	Hose Clamp, stepless, 3/8" ID (#170)	11	Secures 3/8" beverage tubing	45
34-1134-1	Hose Clamp, stepless, 1/2" ID (#198)	7	Secures 1/2" beverage tubing	46
34-1151-1	Hose Clamp, stepless 1/4" ID, red line (#140)	14	Secures 1/4" red line beverage tubing	47
46-1423-9	Cable Tie, 5-3/4" long	10	Secures tubing labels	48
10560431	Cable Tie, 14" long	20	Secures tubing	49
10667440	Hybrid Bulk Syrup Label Kit	1	Identifies components	

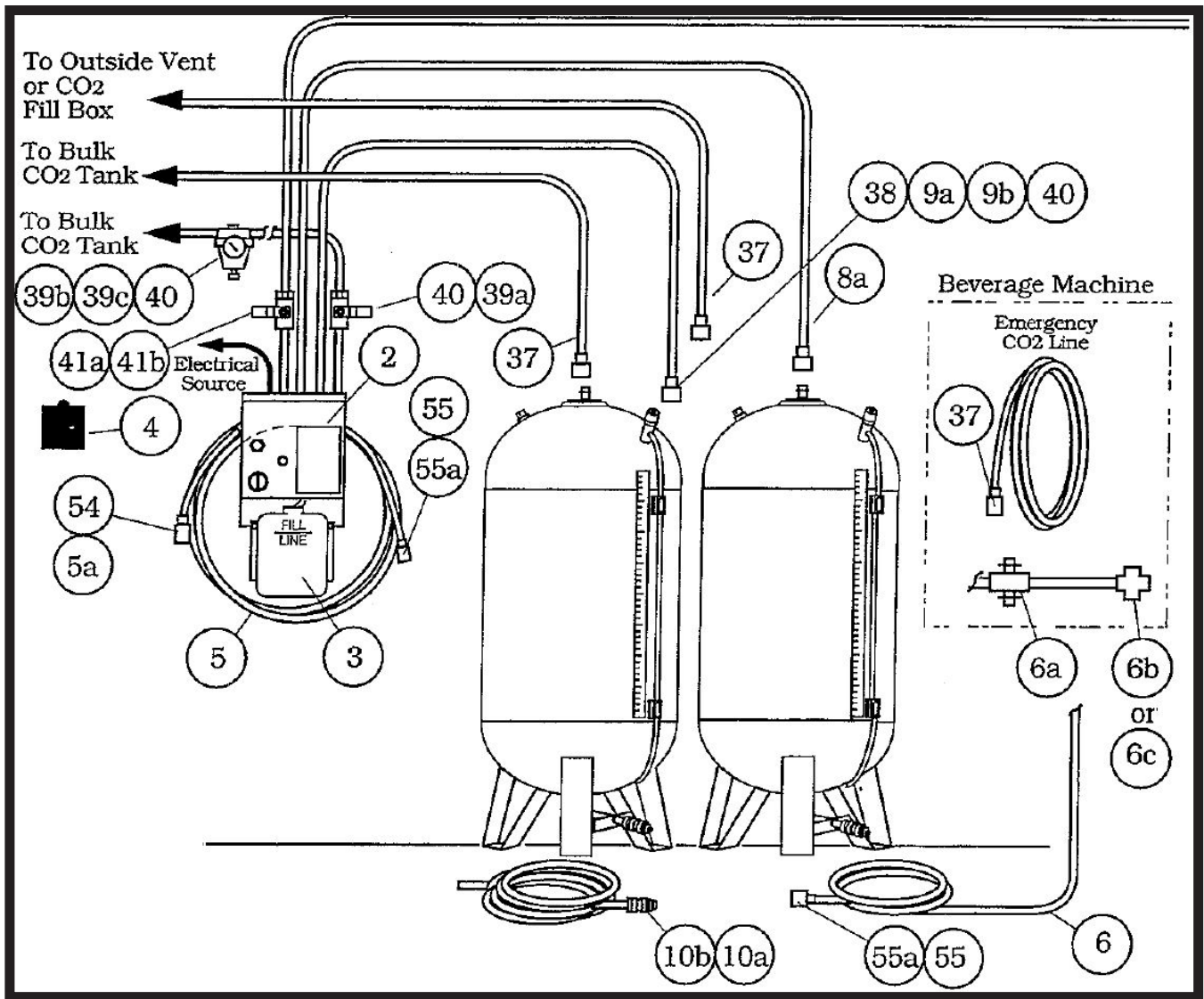

Hybrid Bulk Syrup System

Hybrid Bulk Label Kit

The following parts are included in the Hybrid Bulk Label Kit (PN 10667440):

PN	Description	Qty	Function	Item
10677285	Label, CIP Operation Guide	1	Summarizes operating procedures for sanitizing tanks	26
38-1831-9	Label, Sanitize Tank	2	Identifies sanitize lines from CIP to tanks	50
38-1832-9	Label, Tank Pressure	1	Identifies CO ₂ pressure line for syrup tanks	7a
38-1833-9	Label, Vent	1	Identifies vent line for tanks	11a
38-1834-9	Label, Drain	1	Identifies drain line for tanks	10c
38-1835-9	Label, Syrup Supply	1	Identifies syrup supply hose from tanks to beverage machine	6d
38-1975-9	Label, Emergency CO ₂ Supply	1	Identifies emergency air/CO ₂ supply line	51a
38-1883-9	Label, "1"	1	Identifies tank No. 1	1a
38-1884-9	Label, "2"	1	Identifies tank No. 2	1b
38-1885-9	Label, "3"	1	Identifies tank No. 3	1c

Hybrid Bulk Tubing Kit

The following parts are included in the Hybrid Bulk Tubing Kit (PN 10667466).

PN	Description	Qty	Function
28-1141-6	1/4" ID Beverage Tubing, "blue" line	30 ft.	Tubing for 1/4" sanitize line from CIP to syrup tanks
28-1160-6	1/4" ID Beverage Tubing, "red" line	75 ft.	Tubing for CO ₂ supply line to CIP and CO ₂ tank pressure and emergency CO ₂ /air lines to syrup tanks
28-1161-6	1/4" ID Beverage Tubing, "green" line	75 ft.	Tubing for syrup tank vent line
28-1158-6	3/8" ID Beverage Tubing, "red" line	90 ft.	Tubing for water supply line to CIP, 3/8" sanitize line to tanks and branches of the syrup supply line
28-1149-6	1/2" ID Beverage Tubing, "blue" line	20 ft.	Tubing for drain line from jumper hose / tanks to drain

Special Installation Parts

For some individually identified stores Chart may supply additional special installation parts in order for the installer to perform a proper installation. When such special installation parts are required they must be ordered either by the installer or by the store management. Special installation parts will be listed on the packing list which accompanies the Hybrid Bulk installation kit or the special installation parts themselves.

Defective or Missing Parts

Chart has a very rigorous quality assurance program; however, for a variety of reasons it may be that a tank or installation kit arrives at a store with defective or missing parts. When such an incident occurs, Chart is anxious to know about it. Defective or missing parts should be reported to Chart at the address or telephone number shown in this manual.

Chart will not cover missing or damaged parts which are the result of events that occur during shipping, in transit storage, or at any time after the parts leave Chart's factory.

In most cases in transit damage or losses are covered by either the carrier or an insurance policy. It is therefore, important that the installer or initial recipient inspect the parts immediately upon their arrival for damage or loss. If loss or damage is found or suspected, the installer or initial recipient should note the facts on the carrier's documents, notify the carrier or insurer immediately, and follow the instructions outlined by the carrier, the insurance policy or their representatives.

Defective parts should be returned to the Chart factory as soon as possible or as specifically directed by Chart. In markets where a "McBulk rollout" is being organized or managed by a local beverage supplier or corporate office, all inquiries for disposition of defective parts should be directed to the local market's rollout manager. In "rollout" markets return of parts should be consolidated and coordinated by the local manager.

In all cases, prior to returning any parts, contact Chart at the address and telephone number shown in the Warranty section of this manual in order to receive:

- Shipping Instructions
- A “Ship-To” Address
- A Customer Return Authorization Number (CRA)

Parts which are returned without following these instructions may not receive credit.

Common sense would suggest that the installer:

- Carry with them a supply of certain key installation parts, and/or
- Inspect the tanks and installation kit before arriving at the installation site, and/or
- Carry several installation kits on their service vehicle.

Component Identification

Bulk Syrup Tank

PN	Description	Qty	Function	Item
10648337	Tank Closure with Spray Head	1	Closes and sanitizes tank	12
11508969	Rupture Disc, 87 psi maximum	1	Protects tank against excess pressure	13
65-1163-1	Sanitize/Pressurize/Vent Connection, male 2-pin	1	Connection for sanitizing, pressurizing and venting tank	14
65-1166-1	Syrup Fill/Sanitize Connection, 3/4" quick connect nipple, SS	1	Connection for filling and sanitizing tank	15
28-1142-6	Liquid Level Gauge Protector, .625" ID x 36", plastic	1	Protects liquid level gauge	16a
65-1165-1	Syrup Supply/Drain Connection, 1/2" quick connection nipple, SS	1	Connection for syrup withdrawal and draining sanitizer solution	17
39-1089-6	Dust Cap, 1/2", rubber	1	Protects syrup supply/drain connection	17a
39-1090-6	Dust Cap, 3/4", rubber	1	Protects syrup fill/sanitize connection	15a
23-0001-1	O-ring, 1/4" thick, Buna-N	1	Seals closure to tank	12a
39-1091-6	Dust Cap, 2-pin	1	Protects 2-pin sanitize/pressurize/vent connection	14a
47-1061-9	Gasket, .312" x .50", Buna-N	1	Seals 2-pin connector to lid	14b
19-1158-1	Rupture Disc Holder, SS	1	Holds rupture disc (plug & body)	13a
23-0002-9	O-ring, .812" x .937"	1	Seals 3/4" nipple to tank and 3/4" coupler to jumper hose	52
28-1141-6	Liquid Level Gauge Tubing, 1/4" ID x 60" beverage tubing	60 in.	Indicates syrup level and contents	16
54-1085-1	Level Gauge Mounting Bracket, SS	2	Holds level gauge and protector to tank	16b
10526997	Double-Faced Tape, 3/4" x 36"	1	Secures mounting brackets to tank	16c
34-1090-4	Ferrule, SS	2	Secures liquid level tubing to tank barbs	16d
23-0003-9	O-ring, .562" x .687"	1	Seals 1/2" nipple to tank and 1/2" coupler to jumper hose	53
38-1611-9	Label, Sanitize	1	Identifies sanitize/pressure/vent connection	1d
38-1612-9	Label, Syrup Supply/Drain	1	Identifies syrup supply/drain connection	1e
38-1615-9	Label, Syrup Fill	1	Identifies syrup fill/sanitize connection	1f
38-1616-9	Label, Liquid Level Indicator	1	Indicates syrup contents in gallons	1g
38-1617-9	Label, Caution	1	Indicates operational precautions	1h
38-1698-9	Label, Caution Procedure	1	Indicates operational precautions	1i
38-1737-9	Label, NSF Listing	1	Indicates compliance with NSF standards	1j
10667511	SSM-80G Hybrid Bulk Syrup Tank, net 75 gal, SS	2 or more	Stores and dispenses bulk syrup	1

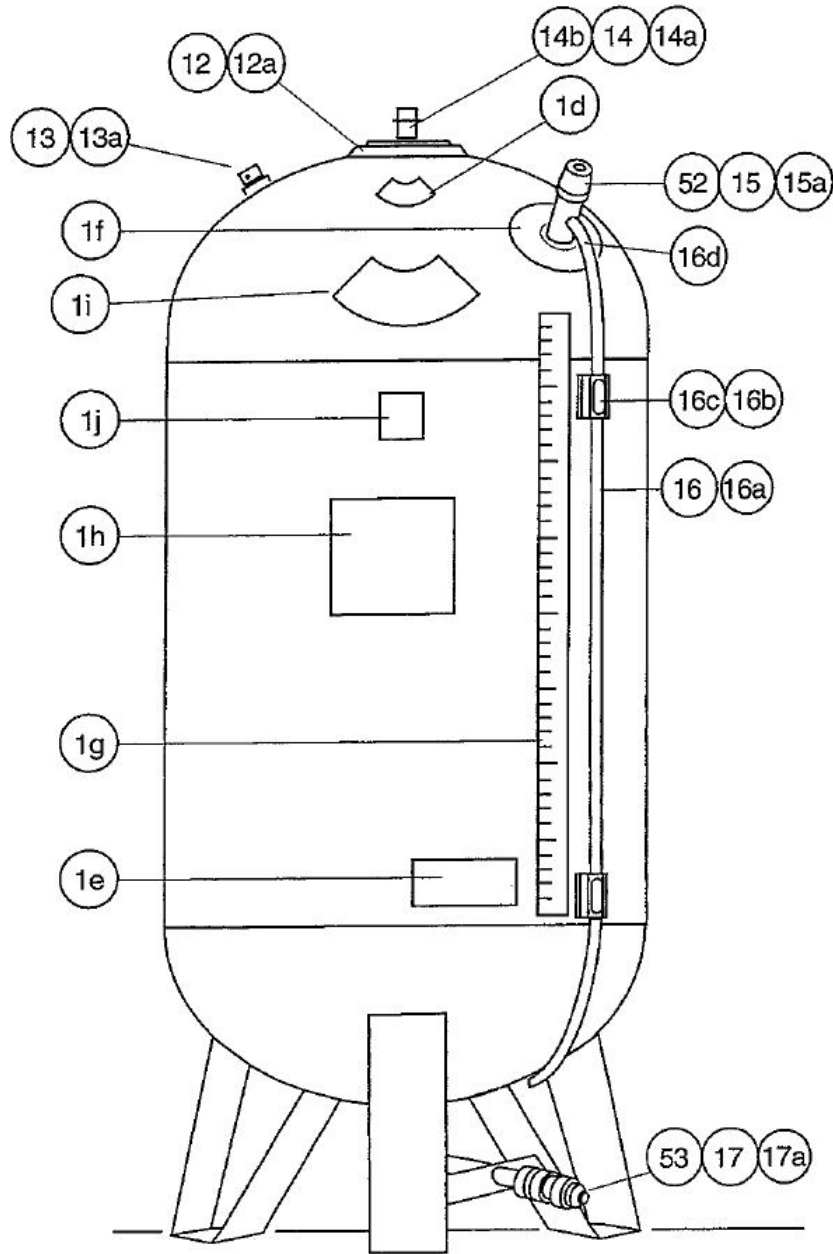

Hybrid Bulk Syrup Tank

InterBulk Clean-In-Place Panel (CIP)

PN	Description	Qty	Function	Item
46-1390-R	Key Switch Assembly	1	Starts and stops clean-in-place panel (CIP)	24
46-1391-R	Key	1	Activates key switch	25
10526938	Electronic Circuit Board	1	Controls CIP functions	23
	Timer Light	1	Indicates CIP operation (part of circuit board)	23a
46-1506-9	5 Amp Fuse	1	Protects electronic circuit board	29
10526946	Solenoid Coil, CO ₂	1	Operates CO ₂ solenoid valve	32a
10526946	Solenoid Coil, Water	1	Operates water solenoid valve	30a
10526920	Solenoid Valve, CO ₂	1	Controls flow of CO ₂ through CIP	32
10526920	Solenoid Valve, Water	1	Controls flow of water / sanitizer through CIP	30
10526903	Water Pressure Gauge (0-60 psi)	1	Indicates water pressure entering CIP	33
10526891	Water Regulator	1	Controls water pressure into CIP	34
	Water Inlet Barb, 3/8"	1	Brings water into CIP (part of water regulator kit)	36
46-1422-R	Manual CO ₂ Purge Button	1	Manually purges sanitizer from syrup tanks	22
10526911	Manifold Block, brass	1	Routes water, CO ₂ and sanitizer	31
10526882	CO ₂ Inlet Barb, 1/4"	1	Brings CO ₂ gas into CIP (part of barb kit)	35
10526882	Sanitize Outlet Barb, 3/8"	1	Joins 3/8" ID sanitize line to CIP (part of barb kit)	8b
10526882	Sanitize Outlet Barb, 1/4"	1	Joins 1/4" ID sanitize line to CIP (part of barb kit)	9c
10526962	Sanitizer Inlet Tube	1	Mixes sanitizer into water	27
10527025	Sanitizer Strainer	1	Protects system against particles	28
10526954	Sanitize Solution Container	1	Holds and dispenses sanitize solution	3
10677285	Operation Decal	1	Summarizes sanitize procedures	26

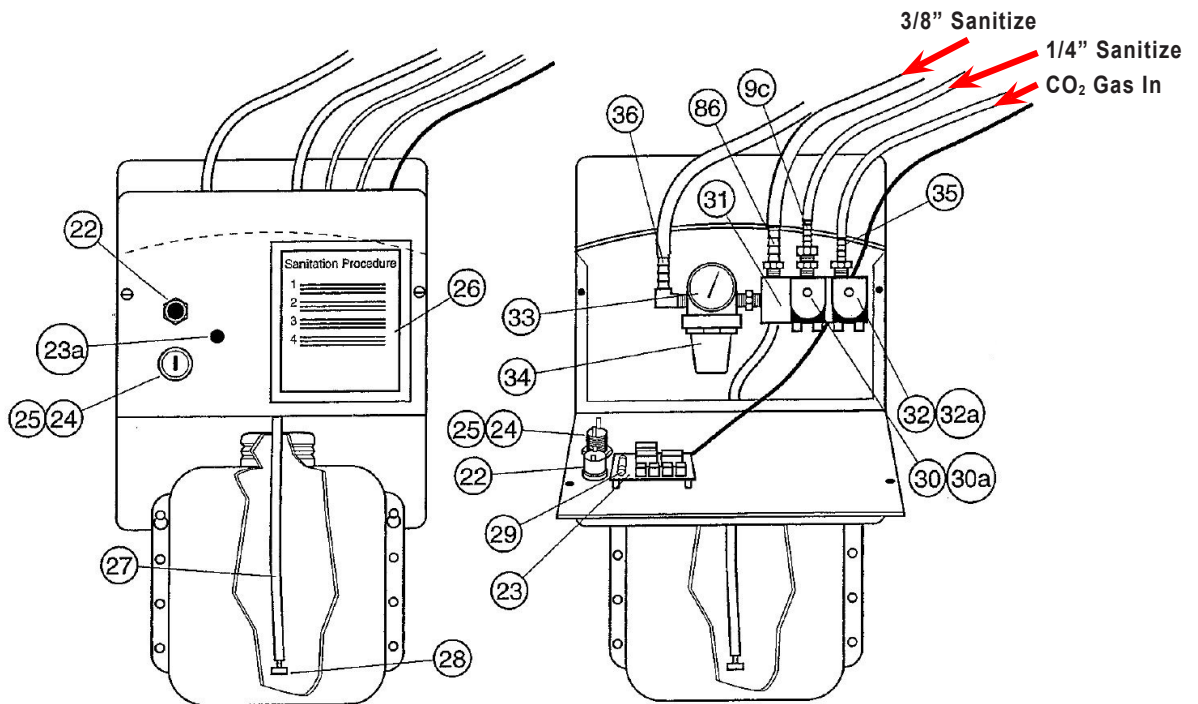

InterBulk Clean-In-Place Panel (CIP)

Miscellaneous Components

PN	Description	Qty	Function	Item
65-1178-1	3/4" Female Quick Connect Coupler Assembly with O-ring and 1/2" hose barb adapter	1	Connects jumper hose to syrup fill/sanitize connection on syrup tank	5a
23-0006-R	Interface O-ring for 3/4" Quick Connect Coupler	1	Seals connection between 3/4" coupler and 3/4" nipple	54
65-1167-1	1/2" Female Quick Connect Coupler Assembly with O-ring and 1/2" hose barb adapter	1	Part of jumper and syrup supply hoses which connect to syrup supply/drain fitting on syrup tank	55
23-0007-R	Interface O-ring for 1/2" Quick Connect Coupler	1	Seals connection between 1/2" coupler and 1/2" nipple	55a

Warranty

Warranty Policy

Chart Inc. (“Chart”) warrants to the Purchaser that the Bulk CO₂ Storage Systems equipment (the “Equipment”) shall be free from any defects in workmanship and materials; provided, however, that this warranty shall be limited to Equipment found to be defective within a period of one (1) year from initial use or eighteen (18) months from the date of shipment, whichever expires first, except that parts sold as a spare or for replacement are warranted for ninety (90) days from the date of shipment. Chart also warrants the vacuum in the Equipment for five (5) years from the date of the original Chart invoice. Chart warrants that its services will be performed in a professional and workmanlike manner. All Chart services are warranted for a period of ninety (90) days from the date of their completion.

Purchaser agrees that as a pre-condition to any Chart liability hereunder, Purchaser or its appointed agents shall fully inspect all Equipment immediately upon delivery and shall give Chart written notice of any claim or purported defect within ten (10) days after discovery of such defect.

As a further pre-condition to any Chart liability hereunder, an approved Chart service company must supply both parts replacement and labor and Purchaser must strictly adhere to the Warranty Claims Procedure set forth below. Chart’s sole and exclusive liability under this limited warranty is to the original Purchaser only and is, at Chart’s sole option: (1) repair or replacement of the defective Equipment or parts thereof; or (2) refund the net purchase price of the defective Equipment or parts thereof paid by the original Purchaser; or (3) in the case of nonconforming services, provide equivalent services or refund the net price paid by the original Purchaser for such services. Chart shall not be responsible for providing working access to the defect, including disassembly and reassembly of Equipment or for providing transportation to and from Chart’s repair or factory facility, all of which shall be at Purchaser’s risk and expense.

This limited warranty does not apply to Equipment that Chart determines to have been caused by the effects of normal wear and tear, erosion, corrosion, fire, flood, explosion or other excessive external forces, misuse, abuse, negligence or accident. Alterations or repairs by any party other than those designated and approved in writing by Chart, or installation, storage, maintenance or operation of such Equipment in a manner inconsistent with Chart accepted practices, normal operating instructions, specifications and drawings, or outside the specified design conditions, unless pre-authorized in writing by Chart, shall void this limited warranty. Modifications in any way to the Equipment without Chart’s prior written approval shall render this warranty void. This limited warranty does not apply to Equipment comprised of materials provided or a design stipulated by Purchaser

or to Equipment purchased used. Negligent handling of the vacuum by the Purchaser or others, or testing of the vacuum levels by any party other than Chart designated and approved party shall render the vacuum warranty void.

Repairs or replacements made pursuant to warranty shall not renew or extend the applicable original warranty period; provided however, that any such repairs or replacement of Equipment or parts thereof shall be warranted for the time remaining in the original warranty period or thirty days, whichever is longer.

Individual parts replacements under warranty and with a component list price less than \$50.00 will be replaced at no charge. Individual components costs exceeding \$50.00 that are replaced under warranty will be invoiced to the Purchaser and the Purchaser will be issued credit based on results of Chart’s evaluation of the returned component(s). The Return Material Authorization (RMA) process must be initiated prior to shipment of any replacement parts.

Chart is not liable for component replacement labor exceeding two hours for actual replacement and two hours travel time (four hours @ 65.00/hour maximum).

Chart specifically makes no warranties or guarantees, expressed or implied, including the warranties of merchantability of fitness for a particular purpose or use, or warranties arising from course of dealing or usage of trade, which are all expressly disclaimed, other than limited warranties expressly specified herein.

In no event shall Chart be liable for any special, indirect, incidental or consequential damages, including but not limited to loss of profits, lost opportunity, loss of use of the equipment, CO₂ loss, cost of capital, cost of substitute equipment, downtime costs, costs of delays nor for any penalties, whether any such claim for the same is based on contract, warranty, tort, negligence, strict liability or otherwise, Chart’s liability for any such claims whether in contract, warranty, negligence, tort, strict liability, or otherwise or for any loss or damage arising out of, connected with, or from any design, sale, installation, operation or use of the equipment or performance of any services rendered by Chart, shall in no event exceed the purchase price paid to Chart by purchaser for the specific equipment or part thereof or for the services giving rise to the claim. Purchaser agrees to defend, indemnify and hold Chart harmless from any third party claims arising out the use, sale, or lease of the equipment.

This warranty policy is not intended to replace or supersede the warranties, limitations, exclusive remedy and disclaimers set forth in Chart’s Terms and Conditions of Sale. In the event of a conflict between Chart’s Terms and Conditions

of Sale and this Warranty Policy, this Warranty Policy shall control.

Warranty Claims Procedure

1. All warranty claims must be previously authorized by Chart Inc. Telephone / electronic approval may be obtained by contacting Chart's Beverage Systems Technical / Customer Services at:

1-800-247-4446
Fax: 1-952-758-8275

Or by writing to:

Chart Inc.
407 7th Street NW
New Prague, MN 56071
2. Authorization must be obtained from Chart prior to shipping any Equipment to Chart facilities. In order to process the return of a tank its model and serial number must be provided. If approved, a Return Material Authorization (RMA) number will be provided. The RMA number must be prominently indicated on the packing slip and any packaging that accompanies the goods being returned. The customer returning the goods is responsible for all freight, proper packing, and any damage incurred during shipment of the goods back to Chart.

