

Users Manual

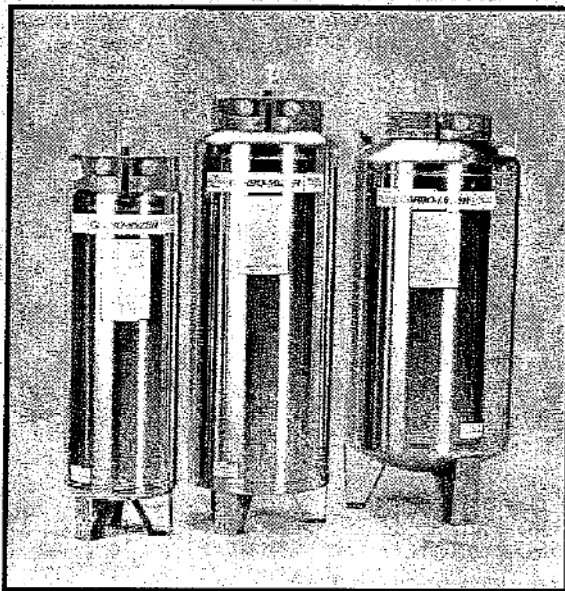

Carbo-Mizer



I Safety

SYSTEM DESCRIPTION

This manual is to be used in conjunction with the normal operation of the MVE Carbo-Mizer CO₂ storage system. The following terms are used throughout this manual.

WARNING Description of a condition that can result in personal injury or death.

CAUTION Description of a condition that can result in equipment or component damage.

NOTE: A statement containing information important enough to emphasize or repeat.

(ITEM) Item numbers used throughout this manual refer to the Parts Identification section, page 4 and 5.

The Carbo-Mizer Storage Tank is designed for the safe storage of carbon dioxide refrigerated liquid. No modifications or changes should be made in the equipment without proper authorization from MVE, Inc..

The following cautions and warnings should be read and understood by all users of CO₂ gas in Carbo-Mizer units before operating or attempting to perform any service work on the equipment.

WARNING: Carbon Dioxide gas is heavier than air and will not support life. Exposure to concentrations of 10% or more can produce unconsciousness or death. Lower concentrations can cause headache, sweating, rapid breathing, increased heart rate, shortness of breath, or dizziness. Carbon dioxide is an odorless gas and should be treated as a material with poor warning properties.

Carbon dioxide is heavier than air so high concentrations may be found in low areas such as basements.

RESCUE AND FIRST AID CONSIDERATIONS

Do not attempt to remove an individual without utilizing proper rescue equipment or you may also become a casualty.

If the exposed person is unconscious, obtain assistance and put into effect the established emergency procedures.

If a person has inhaled large amounts of carbon dioxide and is exhibiting adverse effects, move the exposed individual to fresh air at once. If breathing has stopped, perform artificial respiration. Keep the affected person warm and at rest. Get medical attention as soon as possible.

WARNING: If solid CO₂ (dry ice) or compressed CO₂ gas comes in contact with the skin, eyes, or mouth, stop the exposure immediately and obtain medical attention.

CAUTION: The installation of the Carbo-Mizer should be done so that it does not block electrical boxes or fire escapes. The vent line that connects to the tank's safety relief devices must be free of kinks or obstructions. It must connect to the fill box on the outside of the building. All plumbing connections should be leak free. The hoses connecting the store tank and the filling station should be out of the traffic area and protected from damage.

TABLE OF CONTENTS

I SAFETY INFORMATION	2
II SPECIFICATION	3
III PARTS IDENTIFICATION	4-5
IV OPERATION INSTRUCTIONS	6
V TROUBLESHOOTING	7
VI SYSTEM PARTS AND SERVICE	8

Specifications II

SYSTEM DESCRIPTION

The Carbo-Mizer Bulk CO₂ Storage System is designed to provide users of carbon dioxide a safe, convenient means of storing and delivering carbon dioxide to beverage systems. The Carbo-Mizer System consists of the fill box, fill hose and storage tank.

FILL BOX

The fill box is mounted on the outside of the facility and is used for filling the storage tank with liquid carbon dioxide. It is equipped with a self-closing fill connection which allows the CO₂ delivery person to easily fill the storage tank. Filling does not require the delivery person to enter the facility.

The fill box also serves as a vent location where CO₂ gas from the storage tank safety relief valve can be released harmlessly to the outside.

The fill box is permanently connected to the storage tank with a fill and vent hose.

STORAGE TANK

The storage tank has a vacuum insulated stainless steel pressure vessel located inside a stainless steel outer jacket. The insulation prevents the cold liquid CO₂ from boiling away. It includes an automatic pressure building system to maintain adequate CO₂ gas withdrawal.

An adjustable regulator supplies CO₂ gas to the beverage system at the desired pressure. To prevent carbonator overpressurization, this regulator is equipped with a 130 psi relief valve.

The Carbo-Mizer storage tank is protected from damage due to excessive pressure by a primary and secondary relief device that vents outside into the fill box.

SPECIFICATIONS	CARBO-MIZER 200	CARBO-MIZER 400	CARBO-MIZER 600
Dimensions			
Diameter (in.)	16	20	24
Height (in.)	54	65	63
Empty Weight (lbs.)	170	305	365
Filled Weight (lbs.)	370	705	965
Gross Capacity (liters)	85	170	255
Storage Capacity, Liquid (lbs.)	200	400	600
Gas Use Connection	1/4" male flare	1/4" male flare	1/4" male flare
Fill Connection	3/4" quick coupler	3/4" quick coupler	3/4" quick coupler
Vent Connection	5/8" ODT	5/8" ODT	5/8" ODT
Rates and Pressures			
CO ₂ Delivery Rate (continuous)	4.5 lbs. CO ₂ /hour *	5.5 lbs. CO ₂ /hour *	9 lbs. CO ₂ /hour *
Peak Flow Rate	8.0 lbs. CO ₂ /hour	10 lbs. CO ₂ /hour	15 lbs. CO ₂ /hour
Evaporation Rate	1.5 lbs./day	2.5 lbs./day	3.5 lbs./day
Maximum Allowable Working Pressure	300 psig	300 psig	300 psig
Primary Relief Valve Setting	300 psig	300 psig	300 psig
Secondary Relief Device Setting	450 psig	450 psig	450 psig
Soft Drink Relief Valve (w/check valve)	130 psi	130 psi	130 psi
Design Criteria			
Design Specifications	ASME	ASME	ASME
Fill System	Lo-Loss Single Line Filling	Lo-Loss Single Line Filling	Lo-Loss Single Line Filling
Insulation Type	Super Insulation **	Super Insulation **	Super Insulation **
Liquid Level Gauge	Roto-Cal	Roto-Cal	Roto-Cal
Vacuum Jacket Material	304 Stainless Steel	304 Stainless Steel	304 Stainless Steel
Inner Vessel Material	304 Stainless Steel	304 Stainless Steel	304 Stainless Steel
Fill Box Design	Flush or Surface Mounted	Flush or Surface Mounted	Flush or Surface Mounted
Basic Design	3-6" legs	3-6" legs	3-6" legs

* Approximately 135 drinks per pound of CO₂

** High vacuum

III Parts Identification

CARBO-MIZER STORAGE TANK

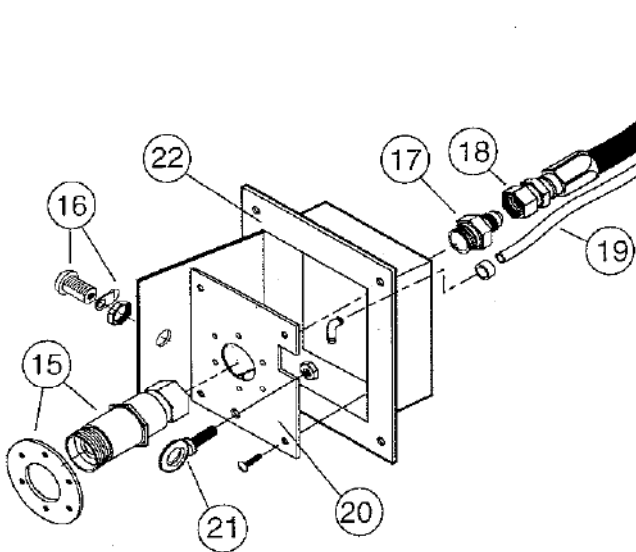
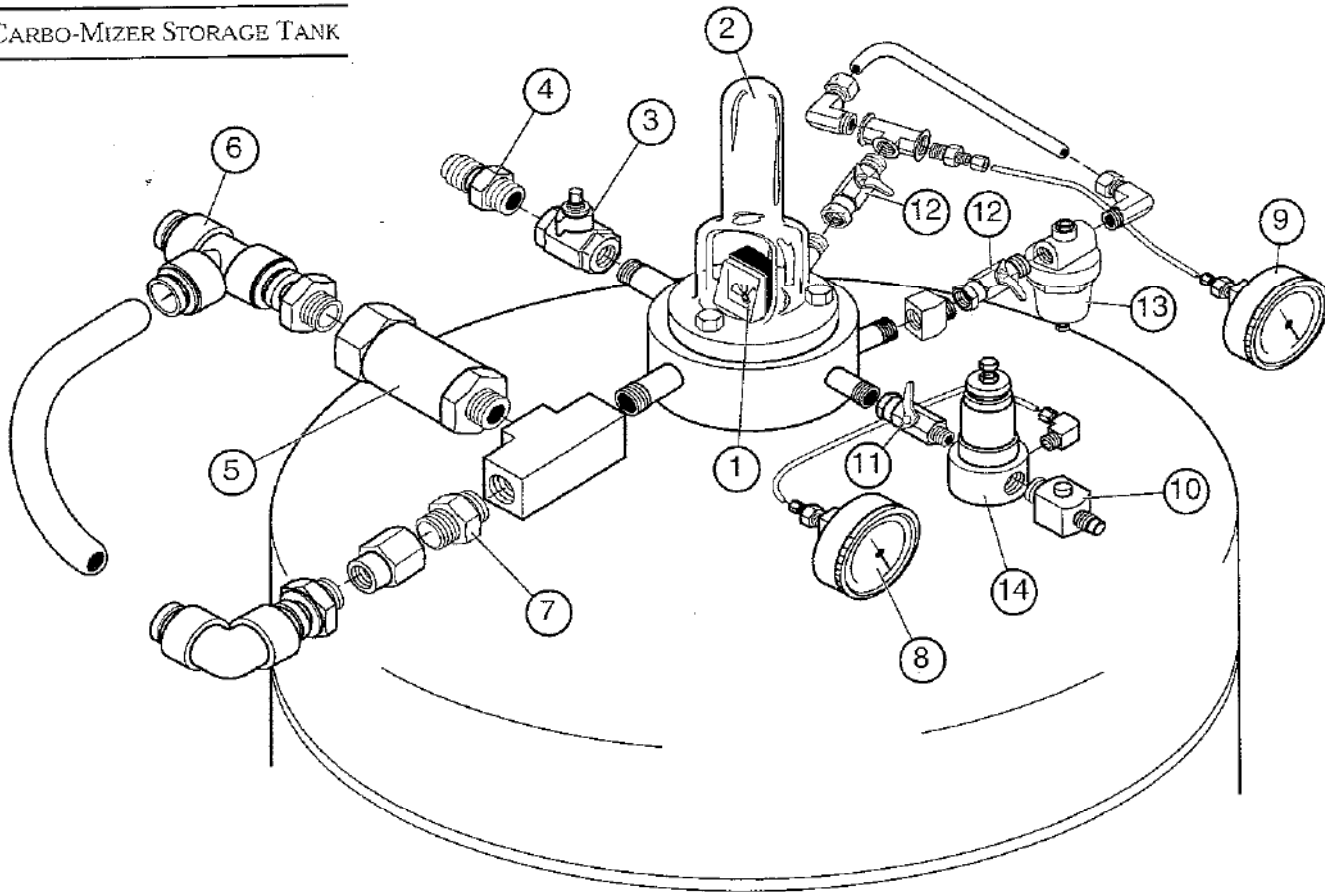

FLUSH MOUNT FILL BOX

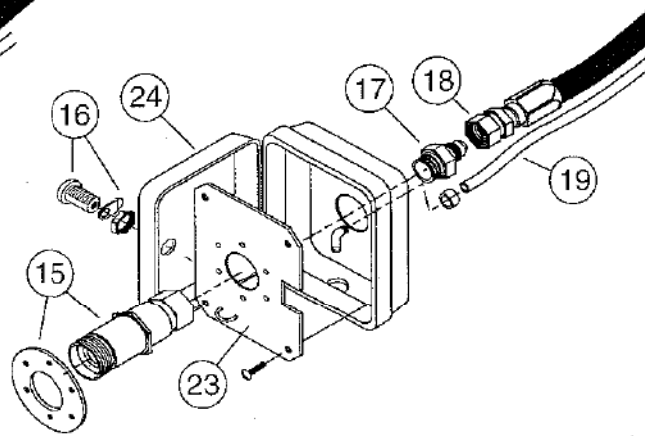

SURFACE MOUNT FILL BOX

Parts Identification III

ITEM NO.	PART NO.	DESCRIPTION	QTY	FUNCTION
1	20-1348-9	Roto-Cal Gauge	1	Shows liquid CO ₂ level.
2	54-1148-6	Level Gauge Protector	1	Protects gauge from damage.
3	17-1461-1	Ball Valve (3/8" FPT)	1	Emergency liquid shut-off
4	11-1011-2	Connection (3/8" MPT x 5/8" - 45° flair)	1	Liquid hose connection
5	18-1125-2	Relief Valve 1/2" (300 psi)	1	Protects inner vessel.
6	10486462	Connector (1/2" MPT x 1/2" ODT x 1/2" ODT)	1	Vent hose connector
7	19-1148-2	Rupture disc 1/2" (450 psi)	1	Protects inner vessel.
8	20-1226-9	Pressure Gauge (0-125 psi)	1	Indicates gas use pressure.
9	20-1227-9	Pressure Gauge (0-400 psi)	1	Indicates storage tank pressure.
10	18-1150-2	Relief/Check Valve (130 psi)	1	Protect beverage equipment.
11	17-1616-2	Ball Valve (1/4" NPT)	1	On/Off for gas supply
12	17-1616-2	Ball Valve (1/4" NPT)	2	Isolation for P.B. Regulator
13	21-1003-2	P.B. Regulator (125 psi)	1	Regulates tank pressure.
14	21-1168-2	Gas Regulator (0-125 psi)	1	Regulates gas use pressure.
15	13-1248-2	Fill Connection Valve	1	Connection for distributor fill hose
16	10521627	Lock Assembly	1	Locks fill box.
17	11-1118-2	Connector	1	Connects fill hose to valve.
18	37-1109-7	Fill Hose	1	Transfers liquid CO ₂ from fill box to tank.
19	28-1172-6	Vent Hose	1	Transfer vent gas from tank to fill box.
20	10503517	Flush Box plate	1	Holds fill connector valve.
21	09-5238-4	Eyelet	1	Locks delivery hose.
22	91-1113-9	Flush Mount Box	1	Mounts into outside wall.
23	55-0322-1	Surface Box Plate		Holds fill connection valve.
24	56-1749-9	Surface Mount Box	1	Mounts on outside wall.

COMPONENT DESCRIPTION

It is important to become familiar with the major components of the Carbo-Mizer system.

Gas is supplied to the beverage equipment through the Final Line Regulator (Item 14) which is mounted directly to the Carbo-Mizer unit. It maintains the proper line pressure for carbonation. This regulator's outlet pressure gauge (Item 8) shows the pressure in the carbonation equipment. Normal operating pressure is between 90-120 psi. In many cases additional regulators may be added after this regulator to supply other functions, such as Bag-in-Box pumps or syrup drive systems. Consult with the suppliers of that equipment for proper pressure recommendations.

The Control Valves for the Carbo-Mizer system are factory set and should not be adjusted. The Pressure Building Valve (Item 13) controls the operating pressure of the storage tank and has a set pressure of 125 psi. It delivers

liquid CO₂ to an internal pressure building coil if the tank pressure is low, and puts the evaporated gas back into the tank to raise the pressure.

The filling of the storage tank with liquid CO₂ is controlled by two valves, the Fill Connection Valve (Item 15) located in the filling station and the Emergency Shut-Off Valve (Item 3) on the tank.

The pressure vessel inside the Carbo-Mizer storage tank is designed to the ASME Section 8, Division 1 Pressure Vessel Code. It has two Safety Relief Devices (Items 5 & 7) that protect it from overpressurization. These devices are vented outside the building into the fill box. The main relief valve (Item 5) may vent during a filling operation.

The Carbo-Mizer storage tank pressure is shown on the Pressure Gauge (Item 9) that is built into the top shroud.

The Liquid Level Gauge (Item 1) is a dial gauge that indicates the amount of liquid CO₂ in the storage tank.

IV Operation

TANK OPERATING FACTS

1. Normal tank operating pressure (gauge on tank) is between 110-150 psi.
2. Tank pressure may be as high as 300 psi after delivery.
3. Line pressure (gauge on regulator) is normally 90-100 psi.
4. Frost near bottom of tank is normal during periods of high CO₂ draw, ie. lunch hour rush and dinner rush.
5. If frost appears continuously, there is a leak in the beverage system or it is on CO₂ drive.
6. Amount of CO₂ in tank is determined by reading the level gauge mounted on the top center of the storage tank.
7. If in an emergency it is necessary to shut the CO₂ supply off, turn the gas supply On/Off valve (Item 11) to the OFF position.

OPERATING INSTRUCTIONS

The Carbo-Mizer bulk CO₂ system requires no adjustments under normal operating conditions. However, the following checks should be taken:

Store Opening

1. Check contents (gauge on the top center).

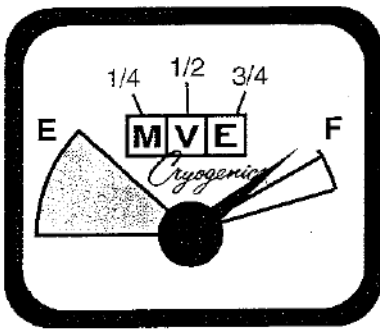

2. Check supply pressure gauge on left. (Should read 90-100 psi.)

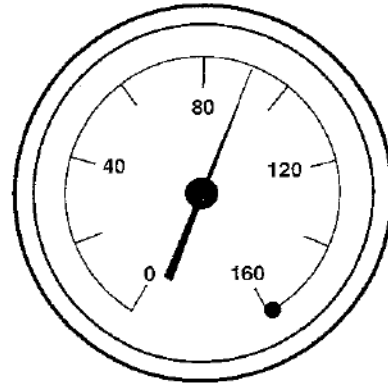

3. Check vessel pressure (gauge on right). Reading varies - usually less than 150 psi, could be as high as 300 psi after a fill.)

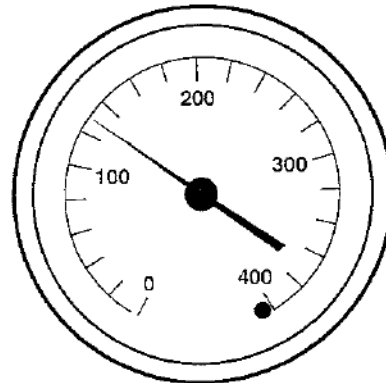

Note: If it is necessary to stop the flow of CO₂ out of the tank, turn gas On/Off valve (Item 11) to the off position. The supply pressure gauge should show 0 psig and the gas flow should stop.

Note: The Carbo-Mizer CO₂ tank is equipped with an emergency liquid shut-off valve (Item 3). Access to this valve is provided using a hole on top of the shroud. Use a pliers to turn the stem.

Troubleshooting V

PROBLEM	PROBABLE CAUSE	CORRECTIVE ACTION
Drinks flat	Out of CO ₂	Check gauge on top of tank. If empty, contact CO ₂ supplier for delivery.
	Final line regulator set too low.	<ol style="list-style-type: none"> 1. Pressure gauge on left should show 90-110 psi. 2. If too low, lift up red ring and turn knurled knob clockwise. 3. If drinks are still flat, then contact service agent.
	Kink or obstruction in CO ₂ line.	Inspect line for kinks or obstruction.
	Large CO ₂ leak.	<ol style="list-style-type: none"> 1. Listen for leaking gas. 2. Inspect line for holes.
	Tank pressure too low.	Pressure gauge on right should be 100-300 psi. If less than 100, then contact service agent.
	Drink temperature too warm.	See manual for beverage system or call service agent.
	Beverage system malfunction.	Contact service agent.
Frost on side of tank near bottom.	High CO ₂ consumption caused by lunch or dinner rush.	None required. Frost will disappear when volume drops.
	Leak in beverage system, figals or bag in box.	If frost appears early in morning or continuously, then system has a leak and service agent must be contacted.
Hissing coming from tank.	Safety relief valve functioning properly.	Check gauge on the tank, if reading is 280 psi or higher, then device is functioning properly.
	Safety relief valve opening too early.	Check reading of right gauge. If pressure is less than 280 psi then relief valve opens too early. Contact service agent.
	Leak in fill hose.	<ol style="list-style-type: none"> 1. Ventilate area to reduce CO₂ concentration. 2. Use pliers or adjustable wrench to close emergency liquid shut-off (Item 3). Grip small rectangular piece and turn so flat sides are parallel to front of tank.
Tank won't fill.	Emergency liquid shut-off valve (Item 3) on fill line closed.	Open valve using pliers or adjustable wrench.
	Tank pressure above 180 psi because it was just filled.	None.
	Blockage in line.	Contact service agent.

VI System Parts and Service

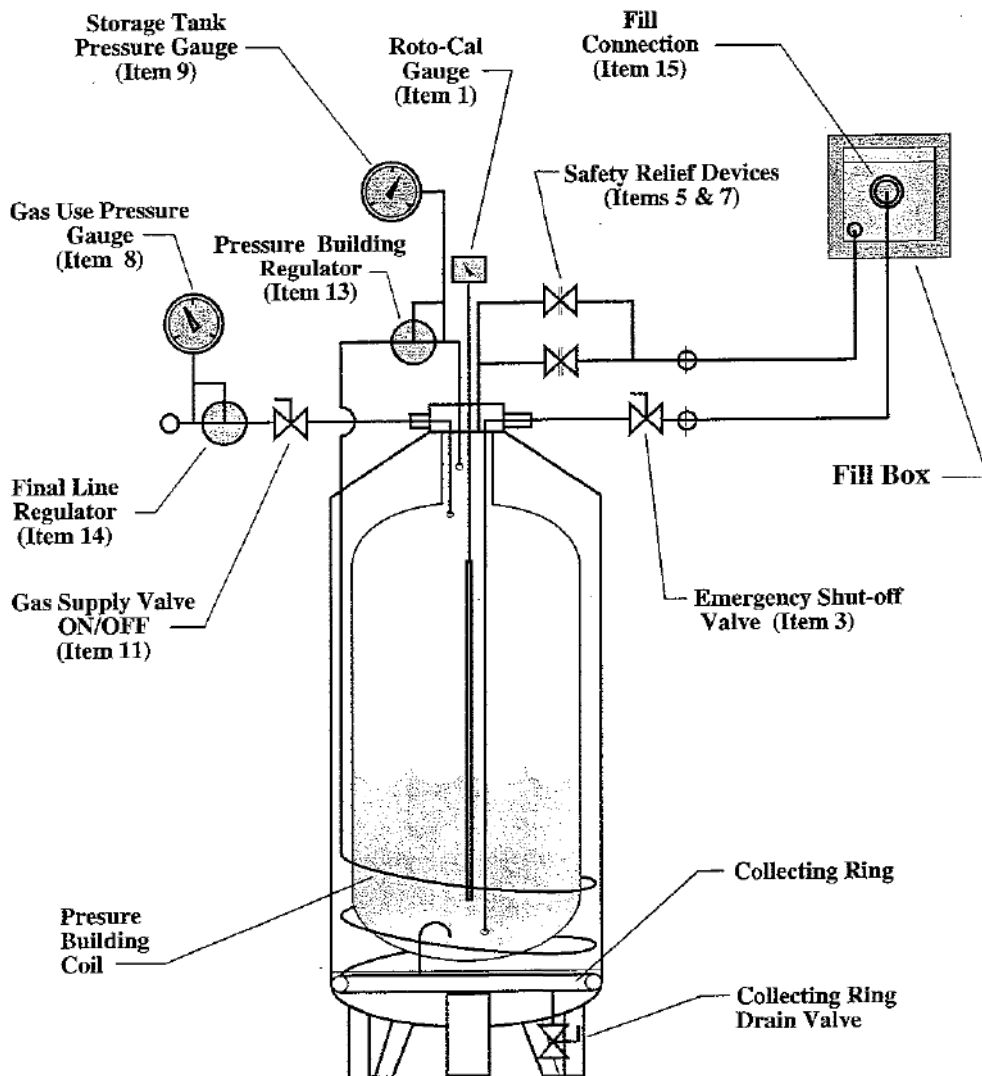

Service and Maintenance

The Carbo-Mizer system is designed to be automatic and only requires the adjustment of the final line regulator (Item 14).

Service or maintenance work should only be performed by MVE Authorized Agents. Contact MVE for the agent in your area.

Use only MVE replacement parts.

Contact MVE:

Technical Service Department
1-800-253-1769

Customer Service Department
1-800-247-4446



MVE, Inc.

3505 County Road 42 West • Burnsville, MN 55306-3803 USA

Tel: U.S. 800-247-4446, Worldwide 612-882-5000 • Fax: 612-882-5185