

MEGA-CYL SERIES

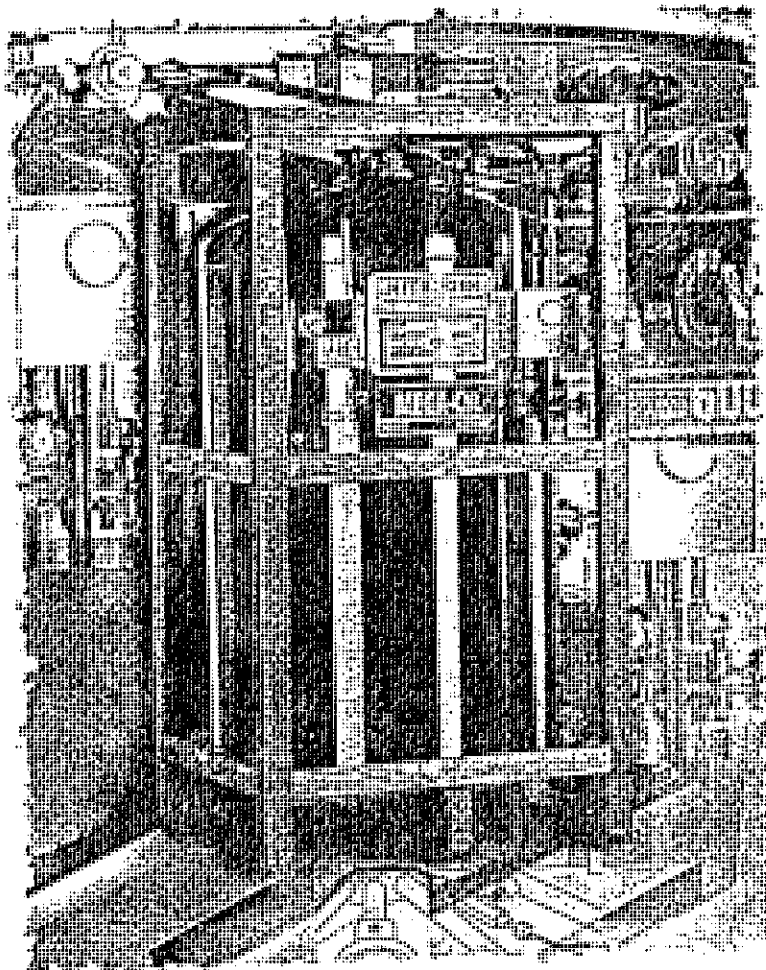

OPERATING MANUAL

- Mega-Cyl 450 MP
- Mega-Cyl 450 HP
- Mega-Cyl 600 MP
- Mega-Cyl 600 HP
- Mega-Cyl 800 MP
- Mega-Cyl 800 HP



General

The Mega-Cyl operating manual is designed to be used in conjunction with all Mega-Cyl models provided by MVE, Inc. This manual contains information regarding the safe operation and handling of liquid nitrogen, argon, oxygen, CO₂ and nitrous oxide with the Mega-Cyl. It should be thoroughly read and understood by anyone that operates the equipment. If there are any questions regarding the operation of the Mega-Cyl, contact MVE's Technical Service division at (800) 253-1769.

This manual is intended to provide the user with all the necessary information needed to install, operate and maintain the Mega-Cyl.

The schematics, piping illustrations and parts list shows a reference number for each component used on the Mega-Cyl. The reference numbers may refer to the same functional component between the various models. The reference numbers will be used throughout this manual to draw specific attention to a component while describing it's function, operation, or repair.

Section 3 discusses the general features of the tank and the theory of operation.

The safety requirements for operating the Mega-Cyl Cylinder, including the handling and transporting of cryogenic products, are shown in section 4. Use this safety section as a "Safety Check-List" each time the equipment is being used.

Section 5 and 6 shows the schematics and specifications for the Mega-Cyl 450, 600 and 800MP and HP models.

Section 7 gives a step by step procedure for the basic operation of the tank.

Sections 8 and 9 indicate how to troubleshoot, maintain and repair the Mega-Cyl.

Section 10 provides you with an explosive view of each tanks plumbing along with a corresponding parts list.

Terms

Throughout this manual safety precautions will be designated as follows:

WARNING – Description of a condition that can result in personal injury or death.

CAUTION – Description of a condition that can result in equipment or component damage.

NOTE – A statement that contains information that is important enough to emphasize or repeat.

Abbreviations

The following abbreviations and acronyms are used throughout this manual:

CBM	Center Back Mount Gauge
CGA	Compressed Gas Association
FPT	Female Pipe Thread
MPT	Male Pipe Thread
MVE	MVE, Inc.
NPT	National Pipe Thread
NR	Not Required
ODT	Outside Diameter Tube Size
P/N	Part Number
PPM	Parts per Million
PSI	Pounds per Square Inch
PSIG	Pounds per Square Inch (Gauge)
SCF	Standard Cubic Feet
SCM	Standard Cubic Meters
SS	Stainless Steel
PB	Pressure Builder
Nm ³	Normal Cubic Meters

TABLE OF CONTENTS

<u>SECTION</u>	<u>PAGE NO.</u>	<u>SECTION</u>	<u>PAGE NO.</u>
1	Preface 3	8	Troubleshooting19-20
	Revision Log	9	Maintenance21-23
2	Table of Contents 4		Adjusting Regulator Pressure Ranges
3	Introduction 5		Bench Setting a Pressure Building Regulator
	Design		Bench Setting an Economizer Regulator
	Distributor/Filling Responsibilities		Rebuilding the Operational Valves
4	Safety 6	10	Parts Identification24-27
	Warnings and Cautions		Mega-Cyl 450 MP/HP
	Handling the Mega-Cyl		Mega-Cyl 600/800 MP
5	Schematics (flow) 7-8		Mega-Cyl 600/800 HP
	Nomenclature		
6	Specifications 9		
7	Operation 10-18		
	Inspection		
	Purging		
	Filling Procedures		
	Calibration Charts		
	Gas Withdrawal		
	Liquid Withdrawal		
	Contents Indicator		

Design

The Mega-Cyl 450/600/800 cryogenic containers, hereafter referred to as the Mega-Cyl Series, is a series of vacuum insulated cylinders that were designed to furnish liquid or gaseous oxygen, nitrogen or argon on a reliable, economical basis.

The Mega-Cyl Series will hold 450, 600, 800 liters of cryogenic product respectively. The containers have a pressure range from 0 to approximately 250 psig except for the 450HP, 600HP and 800HP which have a pressure range from 0 to approximately 350 psig. The product can then be dispensed as either liquid or gas.

Gas withdrawal is accomplished through a self-contained vaporizer that will provide continuous flow rates up to 880 scfh.

An internal pressure building system is provided with these containers. It is sized to maintain pressure while gas withdrawal is taking place. This system is automatically controlled by the pressure building regulator, but can be isolated by actuating the pressure building valve.

The insulation system is comprised of multiple layers of foil and paper that are incorporated with a very low vacuum. The vacuum is factory sealed and with the aid of internal molecular sieve it should remain low for the life of the container. This insulation system coupled with low heat leak supports allows a small amount of heat into the inner vessel where it vaporizes liquid. If the container is left unused for a period of time the pressure will build to the safety relief valve setting. However, if the container is used in gas withdrawal service after pressure has built, the economizer system will automatically reduce the head pressure in the container without loss of product.

The design and construction of the Mega-Cyl Series is aimed at building the most durable tank available today. The inner vessel is constructed of stainless steel and designed to the applicable pressure vessel code. The outer container is constructed of stainless steel to make the Mega-Cyl Series a maintenance-free container. The Mega-Cyl Series can be mounted in a carbon steel pallet and frame.

The inner pressure vessel is protected from over-pressurization by a safety relief valve set at 250 psig (350 psig on the 450HP, 600HP and 800HP) and a rupture disc that is set at 400 psig (450 on HP). The outer container of vacuum space is protected by a reverse buckling rupture disc that is set at a maximum of 25 psig.

Responsibilities of Distributor and Fillers of Liquid Cylinders

MVE is stating below the responsibilities of the filler for any Mega-Cyl Series container.

1. The cylinder must be in a safe condition.

The filler is responsible for confirming that any Mega-Cyl to be filled is in its proper working condition. This includes that

- It has an acceptable vacuum.
- The relief system is in place and functioning.
- There is no structural damage to the cylinder.
- All warning labels are in place and legible.

2. Do not overfill.

The Mega-Cyl Series containers are not to be filled beyond the recommended filling limits described in this manual.

3. Dispense only to knowledgeable users.

The filler must determine that the user is knowledgeable about the general characteristics of the product and the proper safety precautions for its use. Do not allow customers to fill their own cylinders.

4. Dispose of cylinders properly.

To eliminate the risk of injury from the improper reuse of cryogenic (vacuum jacketed) cylinders, before disposal, destroy the cylinder's pressure retaining capability.

We recommend:

1. Purge the cylinder's contents.
2. Drill multiple holes through the cylinder and its vacuum casing or otherwise puncture the tank.

Do it yourself! Don't assume it will be done by the scrap dealer.

While MVE, Inc. equipment is designed and built to rigid standards, no piece of mechanical equipment can ever be made 100% safe. Strict compliance with proper safety and handling practices are necessary when using a liquid cylinder or other compressed gas equipment. We recommend that all our customers re-emphasize safety and safe handling practices to all their employees and customers. While safety features have been designed into the unit and safe operations are anticipated, it is essential that the user of the Mega-Cyl Cylinder Series carefully read to fully understand all WARNINGS, CAUTIONS and NOTES listed in this safety section and enumerated below.

WARNING: Excess accumulation of oxygen creates an oxygen enriched atmosphere (defined by the Compressed Gas Association as an oxygen concentration above 23 percent). In an oxygen enriched atmosphere, flammable items burn vigorously and could explode. Certain items considered non-combustible in air may burn rapidly in such an environment. Keep all organic materials and other flammable substances away from possible contact with oxygen; particularly oil, grease, kerosene, cloth, wood, paint, tar, coal dust, and dirt which may contain oil or grease. DO NOT permit smoking or open flames in any area where oxygen is stored, handled, or used. Failure to comply with this warning may result in serious personal injury.

WARNING: Nitrogen and argon vapors in air may dilute the concentration of oxygen necessary to support or sustain life. Exposure to such an oxygen deficient atmosphere can lead to unconsciousness and serious injury, including death.

WARNING: Before removing cylinder parts or loosening fittings, completely empty the liquid cylinder of liquid and release the entire vapor pressure in a safe manner. External valves and fittings can become extremely cold and may cause painful burns to personnel unless properly protected. Personnel must wear protective gloves and eye protection whenever removing parts or loosening fittings. Failure to do so may result in personal injury because of the extreme cold and pressure in the cylinder.

CAUTION: Only use replacement equipment which is compatible with liquid oxygen and has been cleaned for oxygen use. Do not use regulators, fittings, hoses, etc., which have been previously used in compressed air service. Similarly, do not use oxygen equipment for compressed air. Failure to comply with these instructions may result in serious damage to the liquid cylinder.

CAUTION: The Mega-Cyl Series containers should be moved using a fork truck that lifts the cylinder from beneath the pallet. The Mega-Cyl must be used and stored in a vertical position. Do not lay, store, or ship a liquid cylinder on its side. Failure to comply with these procedures may result in damage to the liquid cylinder.

Handling the Mega-Cyl

The Mega-Cyl is mounted on a coated carbon steel pallet. The preferred handling method is a forklift that lifts the pallet-mounted tank from beneath the pallet. However, overhead lifting by using lugs located on top of the pallet or on top of the cylinder is permitted. Lifting of the Mega-Cyl should be performed only with equipment rated for the weight of the cylinder, pallet and contents combined (see pg. 9).

This container should remain upright at all times. Never lay the unit on its side to move or transport it. Careless handling can cause damage to the support system and internal plumbing, which may result in serious personal injury.

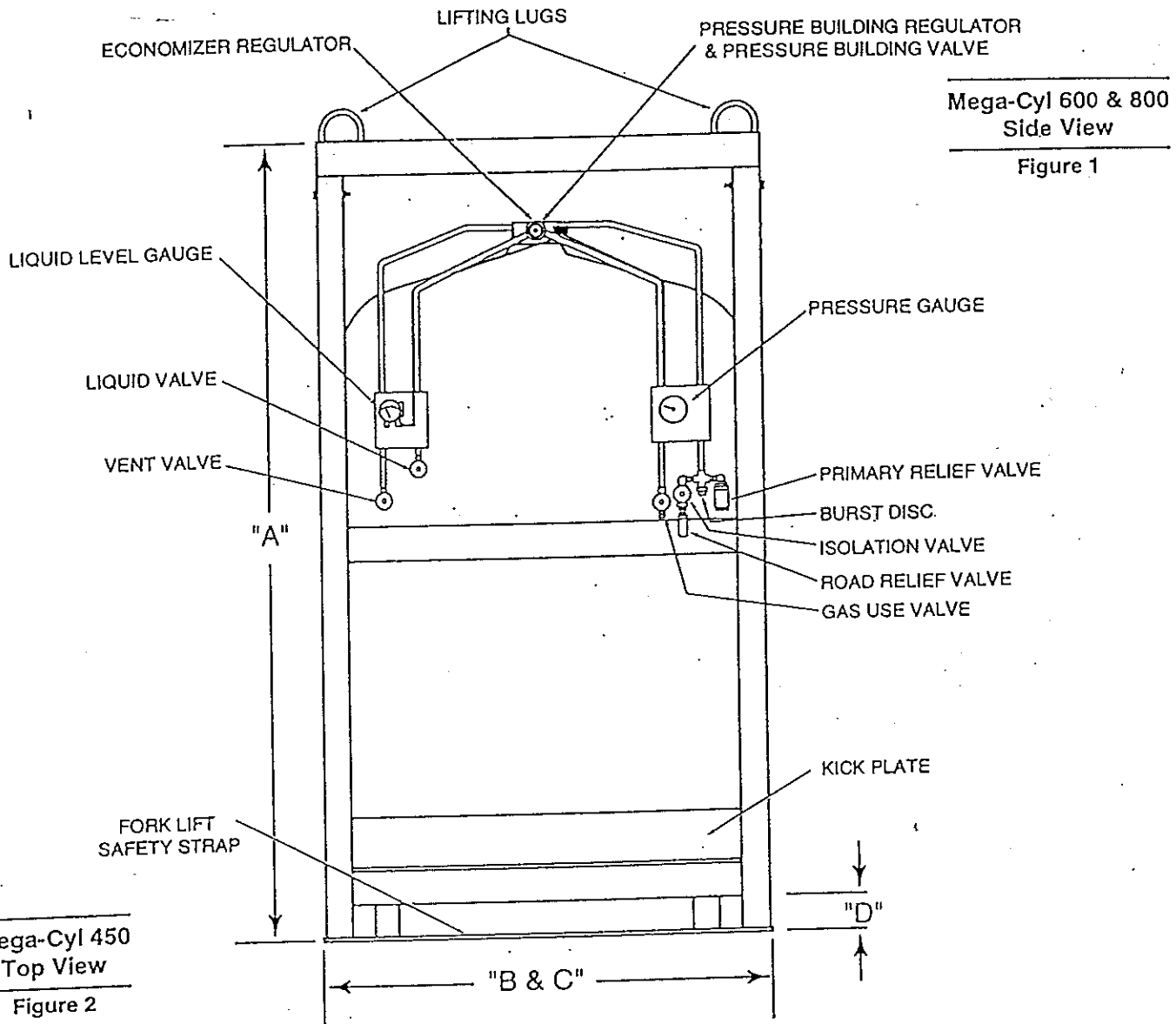

Mega-Cyl 600 & 800
Side View
Figure 1

Mega-Cyl 450
Top View
Figure 2

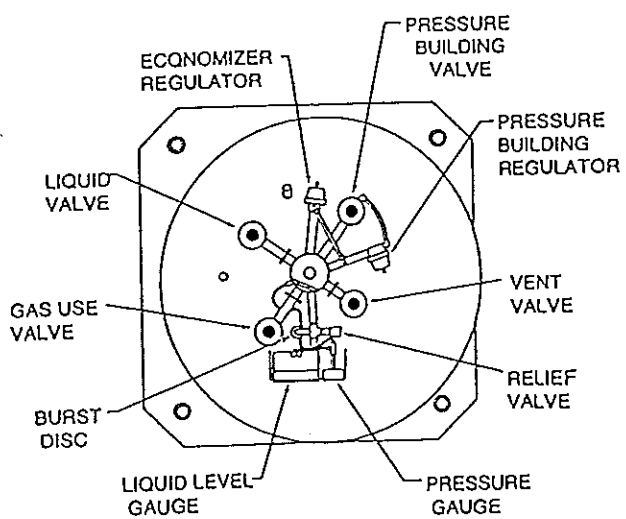

Model	Mega-Cyl 450 MP/HP	Mega-Cyl 600 MP/HP	Mega-Cyl 800 MP/HP	
Dimensions (cylinder)				
Diameter	in. (cm)	30 (76.2)	38 (96.5)	42 (106.7)
Height	in. (cm)	61 (155)	64 (162)	67.5 (171)
Dimensions (frame)*				
"A" Height	in. (cm)	73.75 (187)	72 (183)	80 (203)
"B" Base Width	in. (cm)	34 (86)	40.5 (103)	45 (114)
"C" Base Depth	in. (cm)	34 (86)	40.5 (103)	45 (114)
"D" Leg Height	in. (cm)	3.5 (8.9)	3.5 (8.9)	3.5 (8.9)

* Customized pallets are available upon request.

5 SCHEMATICS

Flow Diagram

Figure 3

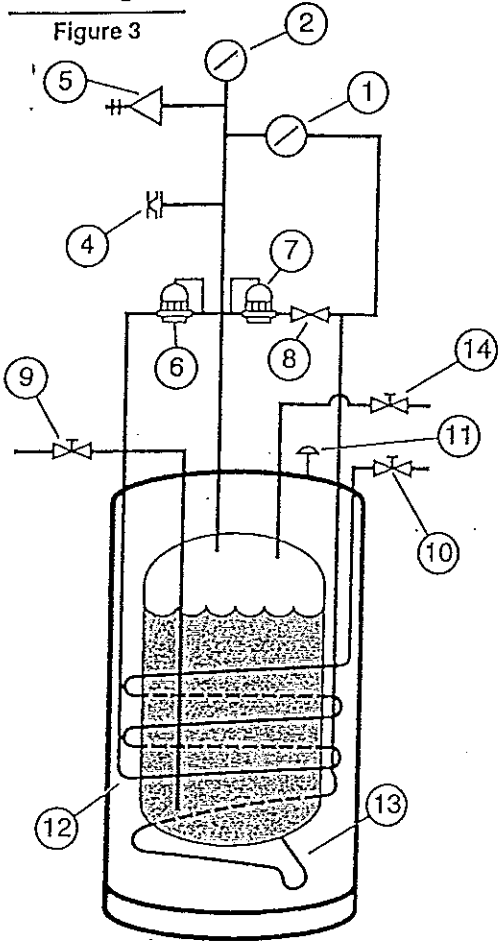

Mega-Cyl 450

Figure 4

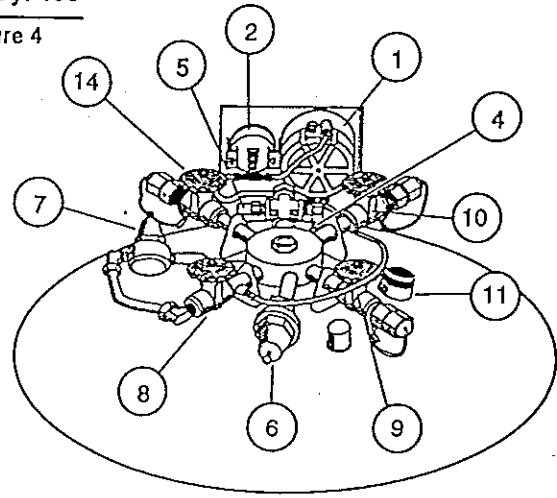

Mega-Cyl 600/800MP/HP

Figure 5

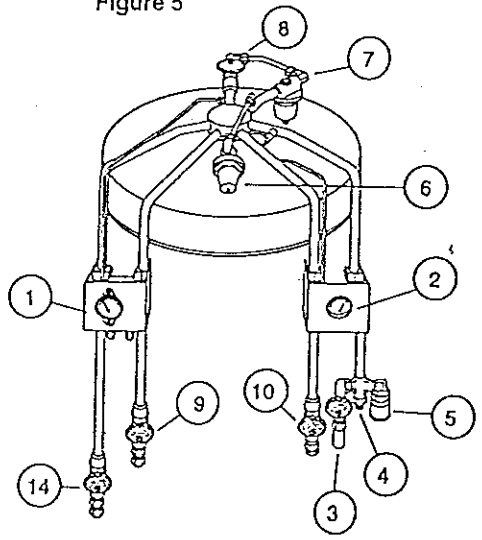

Nomenclature

Ref. #	Plumbing Controls & Function	Ref. #	Plumbing Controls & Function
1	Liquid Level Gauge – To approximate the liquid contents of the liquid cylinder	8	Pressure Building Valve – Isolates the pressure building system
2	Pressure Gauge -- Indicates cylinder pressure	9	FILLiquid Valve – Used for filling or liquid withdrawal operations
3	Road Relief Valve – Maintains pressure below 25 psig for transport over the road	10	Gas Use Valve – Used for gas withdrawal
4	Burst Disc – Secondary relief device	11	Casing Burst Disc – Protects vacuum casing from over pressurization
5	Safety Relief Valve – Primary relief device	12	Vaporizer – Converts liquid into gas
6	Economizer Regulator – Used to automatically reduce pressure	13	Pressure Building Coil – Vaporizes liquid into gas
7	Pressure Building Regulator – Used to automatically build pressure	14	Vent Valve – Used to vent pressure

SPECIFICATIONS

6

Model	Mega Cyl 450		Mega Cyl 600		Mega Cyl 800	
	MP	HP	MP	HP	MP	HP
Dimensions (cylinder)						
Diameter in. (cm)	30 (76.2)	30 (76.2)	38 (96.5)	38 (96.5)	42 (106.7)	42 (106.7)
Height in. (cm)	61 (155)	61 (155)	64 (162)	64 (162)	67 (171)	67 (171)
Design Specification	DOT 4L	DOT 4L	ASME Sec 8	ASME Sec 8	ASME Sec 8	ASME Sec 8
	212	292	Div. 1	Div. 1	Div. 1	Div. 1
Relief Valve psi (Bar)	250 (17)	350 (24)	250 (17)	350 (24)	250 (17)	350 (24)
NER (% per day in O ₂)	1.4	1.4	1.2	1.2	1.2	1.2
Gross Capacity						
gal. (liter)	119 (450)	119 (450)	174 (660)	174 (660)	233 (880)	233 (880)
Net Capacity						
gal. (liter)	113 (428)	113 (428)	159 (600)	159 (600)	211 (800)	211 (800)
Gas Capacity *						
Oxygen scf (m ³)	11,474 (324)	11,124 (315)	18,240 (516)	18,240 (516)	24,320 (689)	24,320 (689)
Nitrogen scf (m ³)	9,289 (263)	8,875 (251)	14,755 (418)	14,755 (418)	19,672 (557)	19,672 (557)
Argon scf (m ³)	11,005 (311)	10,812 (306)	17,823 (504)	17,823 (504)	23,767 (673)	23,767 (673)
CO ₂ scf (m ³)	—	8312 (235)	—	—	—	—
N ₂ O scf (m ³)	—	8211 (232)	—	—	—	—
Gas Delivery Rate						
N ₂ , O ₂ , Ar scfh (M ³ /hr)	575 (16)	575 (16)	750 (21)	750 (21)	880 (25)	880 (25)
CO ₂ , N ₂ O scfh (M ³ /hr)	—	195 (6)	—	—	—	—
Tare Weight **						
Cylinder w/frame lbs. (kg)	1050 (477)	1175 (534)	1500 (682)	1700 (773)	2250 (1023)	2500 (1136)

- * Mega-Cyl 450 based on DOT 4L fill densities.
- Mega-Cyl 600/800 based on net volume at 0 psig.
- ** Weights are approximate and vary with pallet design.

Initial Inspection

When the container is first received it should be inspected for shipping damage. Never fill a damaged container.

All Mega-Cyls are shipped with low purity nitrogen gas in them. For this reason any container that is to be put into oxygen or argon service should be thoroughly purged with the applicable gas.

Purging the Mega-Cyl

Before any operation that involves pressure or handling of a cryogenic fluid, be sure that all safety precautions are taken. See section 4, "Safety" for review.

- a. Open the vent valve to remove any pressure that has built in the inner vessel.
- b. Open the pressure building valve to boil away any cryogenic liquid that remains in the vessel.
- c. After the liquid has been boiled away and the outside of the container shows no frost, close the pressure building valve.
- d. Warm the inner vessel with warm nitrogen gas through the liquid valve. Check the gas temperature as it escapes through the open vent valve.
- e. Close the liquid valve, gas use and pressure building valves.
- f. Attach a vacuum pump to the vent valve and evacuate the inner vessel to 26 inches of mercury.
- g. Break the vacuum to 5 psig with high purity gas, either argon or oxygen, as required by the service of the container.
- h. Repeat steps f and g twice.
- i. Close all valves and remove the vacuum and gas purge lines. The container is now ready for filling.

Filling Procedures (Ref. Nomenclature pg. 8)

The Mega-Cyl 450, 600 or 800 may be filled with liquid from a liquid supply unit either by a pumping or a pressure transfer. If internal pressure of the Mega-Cyl is at

least 20 psi less than the maximum allowable pressure of the supply unit, liquid may be transferred by a pressure transfer. If the normal working pressure of the Mega-Cyl is equal to or greater than the maximum allowable pressure of the supply unit, liquid must be pumped into the tank.

Before filling the Mega-Cyl it should be visually inspected for possible damage or unsuitability for intended use. If damage is detected (e.g., serious dents, loose fitting, etc.), remove the unit from service and conduct the necessary repairs as soon as possible.

Filling the Mega-Cyl 450

The Mega-Cyl 450 is regulated by the US DOT/Transport Canada for transporting liquid oxygen, nitrogen or argon. The filling of these liquid cylinders must be done by product weight. This will allow enough gas space above the liquid to keep the Mega-Cyl from becoming liquid full if its pressure rises to the relief valve setting. The filling weight table indicates the correct product weight for the various relief valve settings. The standard relief valve setting for the Mega-Cyl 450 MP is 250 psig and the 450 HP is 350 psig. The filling procedure will show the proper way to use the filling weight table.

Filling can be accomplished by either pressure transfer or pump fill. The following procedure should be used, refer to the Figures 3 and 4 on page 8:

1. Sample the residual gas that is in the Mega-Cyl. Purge the cylinder if necessary to insure the proper purity.
2. Place the Mega-Cyl on the filling scale. Record the weight. Compare this weight to the registered tare weight on the data plate. The difference is the weight of the residual gas.
3. Connect the transfer hose to the liquid valve (ref.9). Record the new weight. The difference between this weight and the initial weight is the weight of the transfer hose.
4. To determine the total filling weight add the tare weight of the Mega-Cyl, the hose weight and the proper filling weight from the table (pg 13). The table indicates the product across the top and the relief valve pressure down the side. Connect the two columns to find the proper weight. Example:

Mega-Cyl 450 MP for Oxygen at 250 psi has a product weight of 950 pounds.

5. Open the cylinders vent (ref. #14) and liquid valves (ref. #9). Open the transfer line shut-off valve to begin the flow of product.
6. When the scale reads the calculated total filling weight turn off the liquid valve (ref.#9) on the cylinder. Close the vent valve (ref.#14).
7. Close the transfer line shut-off valve and relieve the pressure in the transfer line. Remove the transfer line. Remove the cylinder from the scale.

Filling the Mega-Cyl 600 or 800 ← 1000

To fill the Mega-Cyl 600 or 800 the following procedure should be used, refer to Figures 3, 5 and 6 on page 8:

1. Verify that the container to be filled is reasonably level to prevent over or under filling.
2. If necessary, purge the container prior to filling (refer to the section on purging).
3. Verify that the contents of the supply unit is the proper product to be transferred to the Mega-Cyl.
4. If necessary, start the pressure building system on the liquid supply source to obtain a working pressure that is sufficient enough to allow the liquid to be transferred from the source to the Mega-Cyl.
5. Verify that all container valves are closed.
6. Connect the supply unit transfer hose to liquid fill and withdraw valve (ref. #9).
7. Open vent valve (ref. #14).
8. Open liquid valve (ref. #9) slowly.
9. Continue to fill the container until the proper amount of liquid has been transferred to the container. This is evident when liquid issues from vent valve (ref. #14).
10. Stop the flow of liquid from the supply source.

11. Close liquid fill valve (ref. #9), vent valve (ref. #14).
12. Relieve fill hose pressure by loosening the hose at liquid fill and withdraw connection (ref. #9), then disconnect the hose.
13. Check liquid pressure in the container. If pressure continues to rise as the result of a warm unit, open vent valve (ref. #14) until thermal equilibrium in the container has been achieved. Once achieved, close vent valve (ref. #14).

Gas Withdrawal

The Mega-Cyl will deliver gas at various flow rates and temperatures for different applications. The flow rate is controlled by the equipment that is being supplied gas from the Mega-Cyl. The continuous flow rate indicates the flow rate that will normally provide gas at a reasonable temperature and should not be exceeded. Higher flow rates may provide very cold gas that could damage the equipment that they are attached to. To supply gaseous product follow this step by step procedure: (ref pg 8 - nomenclature)

1. Connect the proper regulator to the liquid cylinders gas use outlet (ref. #10).
2. Connect the proper hose between the final line regulator and the receiving equipment.
3. Open the pressure building valve (ref. #8).
4. Allow pressure (refer to gauge) to build to the operating pressure (125 psi MP/300 psi HP).
5. Open the gas use valve (ref. #10).
6. Adjust the gas use regulator for the proper delivery pressure.
7. When the gas delivery is completed, close all valves.

CAUTION: All valves on an empty Mega-Cyl should always be kept closed to protect the inner vessel and plumbing from being contaminated.

The operator should review the safety precautions found in section 4 "Safety" before conducting a gas or liquid withdrawal operation. Protective eye-glasses and gloves should always be worn.

At low flow rates the Mega-Cyl Series is capable of delivering warm gas through the line regulator. As the flow rate increases the temperature of the gas decreases. If the cold temperature becomes a problem at a desired flow rate, an external vaporizer can be added. Attach this vaporizer directly in series with the gas use connection and place the line regulator at the exit of the vaporizer.

CAUTION: Pressure should be allowed to escape from the transfer hose before it is completely removed. A hose drain and relief valve should be installed in all transfer lines.

Liquid Withdrawal

The Mega-Cyl 600 and 800 Series is equipped with an over the road relief valve set at 22 psig that is useful for low pressure liquid withdrawal. This relief valve can be isolated by closing the shutoff valve immediately upstream.

To transfer liquid, attach the transfer hose to the liquid connection. Slowly open the liquid valve to flow the liquid. The liquid will vaporize at first until the transfer line cools down. A phase separator on the end of the transfer line will help when transferring liquid into open dewars.

Transfer pressure should be kept to a minimum. The normal evaporation of the liquid will usually maintain enough pressure for transferring. If additional pressure is needed, the pressure building valve can be opened until the desired pressure is reached.

CAUTION: The container can become contaminated, once it is emptied, if the liquid and vent valves are not closed.

Contents Indicator

The contents of the Mega-Cyl Series can be determined by means of a differential pressure gauge, calibrated in inches of water column, that is mounted to the left front gauge bracket. The high side signal to the gauge is ported from the upstream side of the pressure building valve. Therefore, to assure an accurate reading on the differential pressure gauge, you should close the pressure building valve before taking a reading from the gauge. The calibration charts on pages 13-18 show contents conversions for O₂, N₂, Ar, CO₂ and N₂O.

Filling Weight Table (Mega-Cyl 450 MP/ HP)

Relief Valve Setting		Oxygen	Nitrogen	Argon	CO ₂	N ₂ O
PSIG	(BAR)	LBS. (KG.)	LBS. (KG.)	LBS. (KG.)	LBS. (KG.)	LBS. (KG.)
0 to 45	(0 to 3.1)	1069 (485)	752 (341)	1316 (597)	-	-
46 to 75	(3.2 to 5.2)	1039 (471)	732 (332)	1287 (584)	-	-
76 to 105	(5.3 to 7.2)	1019 (462)	712 (323)	1257 (570)	1069 (485)	1029 (467)
106 to 170	(7.3 to 11.7)	990 (449)	693 (314)	1207 (547)	1039 (471)	1000 (454)
171 to 230	(11.8 to 15.9)	970 (440)	683 (310)	1178 (534)	1029 (467)	980 (444)
231 to 295 (MP)	(16.0 to 20.3)(MP)	950 (431)	673 (305)	1138 (516)	1009 (458)	960 (435)
296 to 360 (HP)	(20.4 to 24.1)(HP)	921 (417)	643 (292)	1118 (507)	991 (449)	941 (426)

Calibration Chart

Mega-Cyl 450MP/HP

H ₂ O (IN.)	Oxygen			Nitrogen			Argon			CO ₂			N ₂ O		
	GAL.	LB.	CU. FT.	GAL.	LB.	CU. FT.	GAL.	LB.	CU. FT.	GAL.	LB.	CU. FT.	GAL.	LB.	CU. FT.
0.0	0.0	0.0	0.0	0.0	0.0	0.0	0.0	0.0	0.0	0.0	0.0	0.0	0.0	0.0	0.0
2.0	1.0	10	120	2.0	14	187	0.7	8	80	0.9	9	83	0.9	9	79
4.0	3.8	36	437	6.9	47	645	2.6	31	297	3.4	35	303	3.1	33	289
6.0	7.7	73	882	13.1	89	1222	5.5	64	615	7.0	70	616	6.4	68	591
8.0	12.1	115	1389	19.4	131	1811	8.9	103	996	11.1	112	978	10.2	109	946
10.0	16.6	158	1904	25.8	174	2400	12.5	145	1406	15.4	155	1351	14.3	151	1318
12.0	21.0	200	2420	32.1	217	2989	16.2	188	1819	19.6	197	1724	18.3	194	1689
14.0	25.5	243	2935	38.4	259	3578	19.8	231	2232	23.8	240	2097	22.3	237	2061
16.0	30.0	286	3451	44.7	302	4167	23.5	273	2645	28.1	283	2470	26.3	279	2433
18.0	34.5	328	3966	51.1	345	4756	27.2	316	3058	32.3	325	2842	30.3	322	2804
20.0	39.0	371	4481	57.4	387	5345	30.8	359	3471	36.6	368	3215	34.4	365	3176
22.0	43.4	414	4997	63.7	430	5934	34.5	401	3883	40.8	411	3588	38.4	407	3548
24.0	47.9	456	5512	70.0	473	6522	38.2	444	4296	45.1	453	3961	42.4	450	3919
26.0	52.4	499	6027	76.4	515	7111	41.8	487	4709	49.3	496	4334	46.4	493	4291
28.0	56.9	542	6543	82.7	558	7700	45.5	529	5122	53.5	539	4707	50.4	535	4662
30.0	61.3	584	7058	89.0	601	8289	49.2	572	5535	57.8	581	5080	54.5	578	5034
32.0	65.8	627	7573	95.3	643	8878	52.8	615	5947	62.0	624	5453	58.5	621	5406
34.0	70.3	670	8089	101.7	686	9467	56.5	657	6360	66.3	667	5826	62.5	663	5777
36.0	74.8	712	8604				60.2	700	6773	70.5	709	6199	66.5	706	6149
38.0	79.3	755	9120				63.9	743	7186	74.8	752	6572	70.5	749	6521
40.0	83.7	798	9635				67.5	785	7599	79.0	795	6945	74.6	791	6892
42.0	88.2	840	10150				71.2	828	8012	83.2	837	7318	78.6	834	7264
44.0	92.7	883	10666				74.9	871	8424	87.5	880	7690	82.6	877	7635
46.0	97.2	926	11181				78.5	913	8837	91.7	923	8063	86.6	919	8007
48.0	101.7	968	11696				82.2	956	9250	96.0	965	8436	90.6	962	8379
50.0							85.9	999	9663	100.2	1008	8809			
52.0							89.5	1041	10076						
54.0							93.2	1084	10489						
56.0							96.9	1127	10901						
58.0							100.5	1169	11314						

7

OPERATION

Metric Calibration Chart															
Mega-Cyl 450MP/HP															
H ₂ O (IN)	Oxygen			Nitrogen			Argon			CO ₂			N ₂ O		
	LITERS	KG.	M ³	LITERS	KG.	M ³	LITERS	KG.	M ³	LITERS	KG.	M ³	LITERS	KG.	M ³
0.0	0.0	0.0	0.0	0.0	0.0	0.0	0.0	0.0	0.0	0.0	0.0	0.0	0.0	0.0	0.0
2.0	4.0	5	3	7.6	6	5	2.7	4	2	3.6	4	2	3.2	4	2
4.0	14.4	16	12	26.2	21	18	10.0	14	8	13.0	16	9	11.8	15	8
6.0	29.0	33	25	49.7	40	35	20.7	29	17	26.5	32	17	24.2	31	17
8.0	45.7	52	39	73.6	60	51	33.5	47	28	42.1	51	28	38.8	49	27
10.0	62.7	72	54	97.6	79	68	47.3	66	40	58.2	70	38	54.0	69	37
12.0	79.6	91	69	121.5	98	85	61.2	85	52	74.2	89	49	69.2	88	48
14.0	96.6	110	83	145.4	118	101	75.1	105	63	90.3	109	59	84.4	107	58
16.0	113.5	130	98	169.4	137	118	89.0	124	75	106.3	128	70	99.6	127	69
18.0	130.5	149	112	193.3	156	135	102.8	143	87	122.4	148	81	114.8	146	79
20.0	147.4	168	127	217.2	176	151	116.7	163	98	138.4	167	91	130.0	165	90
22.0	164.4	188	142	241.2	195	168	130.6	182	110	154.5	186	102	145.3	185	100
24.0	181.3	207	156	265.1	214	185	144.5	201	122	170.5	206	112	160.5	204	111
26.0	198.3	226	171	289.0	234	201	158.4	221	133	186.6	225	123	175.7	223	122
28.0	215.2	246	185	313.0	253	218	172.3	240	145	202.7	244	133	190.9	243	132
30.0	232.2	265	200	336.9	272	235	186.1	259	157	218.7	264	144	206.1	262	143
32.0	249.2	284	214	360.8	292	251	200.0	279	168	234.8	283	154	221.3	282	153
34.0	266.1	304	229	384.8	311	268	213.9	298	180	250.8	302	165	236.5	301	164
36.0	283.1	323	244				227.8	318	192	266.9	322	176	251.8	320	174
38.0	300.0	343	258				241.7	337	204	282.9	341	186	267.0	340	185
40.0	317.0	362	273				255.6	356	215	299.0	360	197	282.2	359	195
42.0	333.9	381	287				269.5	376	227	315.0	380	207	297.4	378	206
44.0	350.9	401	302				283.3	395	239	331.1	399	218	312.6	398	216
46.0	367.8	420	317				297.2	414	250	347.2	419	228	327.8	417	227
48.0	384.8	439	331				311.1	434	262	363.2	438	239	343.1	436	237
50.0							325.0	453	274	379.3	457	249			
52.0							338.9	472	285						
54.0							352.8	492	297						
56.0							366.6	511	309						
58.0							380.5	530	320						

Calibration Chart

Mega-Cyl 600MP/HP

H ₂ O (IN.)	Oxygen			Nitrogen			Argon		
	GAL.	LB.	CU. FT.	GAL.	LB.	CU. FT.	GAL.	LB.	CU. FT.
0.0	0.0	0.0	0.0	0.0	0.0	0.0	0.0	0.0	0.0
2.0	1.3	12	148	2.5	17	232	0.9	10	99
4.0	4.8	45	549	8.9	60	826	3.3	38	371
6.0	9.9	94	1134	17.5	118	1628	6.9	81	780
8.0	16.0	152	1836	26.8	181	2492	11.5	133	1290
10.0	22.5	214	2589	36.1	243	3358	16.6	193	1865
12.0	29.1	277	3347	45.4	306	4223	21.9	255	2469
14.0	35.7	340	4104	54.6	369	5089	27.3	318	3075
16.0	42.3	403	4862	63.9	431	5955	32.7	381	3682
18.0	48.8	465	5619	73.2	494	6820	38.1	443	4289
20.0	55.4	528	6377	82.5	557	7686	43.5	506	4896
22.0	62.0	591	7134	91.8	620	8551	48.9	569	5503
24.0	68.6	653	7892	101.1	682	9416	54.3	631	6109
26.0	75.2	716	8649	110.4	745	10282	59.7	694	6716
28.0	81.8	779	9407	119.7	808	11148	65.1	757	7323
30.0	88.3	842	10164	129.0	871	12014	70.5	820	7930
32.0	94.9	904	10922	138.3	933	12879	75.9	882	8536
34.0	101.5	967	11679	147.6	996	13745	81.2	945	9143
36.0	108.1	1030	12437	156.8	1058	14603	86.6	1008	9750
38.0	114.7	1092	13194	164.9	1113	15360	92.0	1071	10357
40.0	121.3	1155	13952				97.4	1133	10964
42.0	127.9	1218	14709				102.8	1196	11570
44.0	134.4	1281	15467				108.2	1259	12177
46.0	141.0	1343	16224				113.6	1321	12784
48.0	147.6	1406	16982				119.0	1384	13391
50.0	154.2	1469	17738				124.4	1447	13998
52.0	160.4	1528	18458				129.8	1510	14604
54.0							135.2	1572	15211
56.0							140.6	1635	15818
58.0							145.9	1698	16425
60.0							151.3	1760	17031
62.0							156.7	1822	17630
64.0							161.6	1880	18189

7

OPERATION

Metric Calibration Chart

Mega-Cyl 600MP/HP

H ₂ O (IN)	Oxygen			Nitrogen			Argon		
	LITER	KG.	M ³	LITER	KG.	M ³	LITER	KG.	M ³
0.0	0.0	0.0	0.0	0.0	0.0	0.0	0.0	0.0	0.0
2.0	4.9	6	4	9.4	8	7	3.3	5	3
4.0	18.1	21	16	33.6	27	23	12.5	17	10
6.0	37.3	43	32	66.2	54	46	26.2	37	22
8.0	60.4	69	52	101.3	82	71	43.4	60	37
10.0	85.2	97	73	136.5	110	95	62.7	87	53
12.0	110.1	126	95	171.7	139	120	83.0	116	70
14.0	135.0	154	116	206.8	167	144	103.4	144	87
16.0	159.9	183	138	242.0	196	169	123.8	173	104
18.0	184.9	211	159	277.2	224	193	144.3	201	121
20.0	209.8	239	181	312.4	253	218	164.7	230	139
22.0	234.7	268	202	347.6	281	242	185.1	258	156
24.0	259.6	296	223	382.7	310	267	205.5	286	173
26.0	284.5	325	245	417.9	338	291	225.9	315	190
28.0	309.5	353	266	453.1	366	316	246.3	343	207
30.0	334.4	382	288	488.3	395	340	266.7	372	225
32.0	359.3	410	309	523.5	423	365	287.1	400	242
34.0	384.2	439	331	558.6	452	389	307.5	429	259
36.0	409.2	467	352	593.5	480	414	327.9	457	276
38.0	434.1	496	374	624.3	505	435	348.3	486	293
40.0	459.0	524	395				368.7	514	310
42.0	483.9	552	417				389.1	542	328
44.0	508.8	581	438				409.6	571	345
46.0	533.8	609	459				430.0	599	362
48.0	558.7	639	481				450.4	628	379
50.0	583.5	666	502				470.8	656	396
52.0	607.2	693	523				491.2	685	414
54.0							511.6	713	431
56.0							532.0	742	448
58.0							552.4	770	465
60.0							572.8	799	482
62.0							593.0	827	499
64.0							611.8	853	515

Calibration Chart

Mega-Cyl 800MP/HP

H ₂ O (IN.)	Oxygen			Nitrogen			Argon		
	GAL.	LB.	CU. FT.	GAL.	LB.	CU. FT.	GAL.	LB.	CU. FT.
0.0	0.0	0.0	0.0	0.0	0.0	0.0	0.0	0.0	0.0
2.0	1.5	14	167	2.8	19	262	1.0	11	111
4.0	5.4	52	624	10.2	69	947	3.7	43	420
6.0	11.3	108	1303	20.4	138	1902	7.9	92	891
8.0	18.6	177	2137	31.9	215	2971	13.2	154	1487
10.0	26.6	253	3058	43.5	294	4052	19.3	225	2173
12.0	34.8	332	4004	55.1	372	5133	25.9	301	2912
14.0	43.0	410	4951	66.7	450	6214	32.6	379	3669
16.0	51.3	488	5897	78.3	529	7295	39.3	458	4427
18.0	59.5	567	6843	89.9	607	8377	46.1	536	5185
20.0	67.7	645	7789	101.6	685	9458	52.8	614	5943
22.0	75.9	723	8735	113.2	764	10539	59.5	693	6701
24.0	84.2	802	9682	124.8	842	11620	66.3	771	7459
26.0	92.4	880	10628	136.4	920	12701	73.0	849	8217
28.0	100.6	958	11574	148.0	999	13783	79.7	928	8975
30.0	108.8	1037	12520	159.6	1077	14864	86.5	1006	9733
32.0	117.0	1115	13466	171.2	1155	15945	93.2	1084	10491
34.0	125.3	1193	14413	182.8	1234	17026	100.0	1163	11249
36.0	133.5	1272	15359	194.4	1312	18107	106.7	1241	1200
38.0	141.7	1350	16305	206.0	1390	19188	113.4	1319	12765
40.0	149.9	1428	17251	217.2	1465	20224	120.2	1398	13523
42.0	158.2	1507	18197				126.9	1476	14280
44.0	166.4	1585	19144				133.6	1554	15038
46.0	174.6	1663	20090				140.4	1633	15796
48.0	182.8	1742	21036				147.1	1711	16554
50.0	191.1	1820	21982				153.8	1789	17312
52.0	199.3	1898	22929				160.6	1868	18070
54.0	207.5	1977	23873				167.3	1946	18828
56.0	215.4	2052	24784				174.0	2025	19586
58.0							180.8	2103	20344
60.0							187.5	2181	21102
62.0							194.2	2260	21860
64.0							201.0	2338	22618
66.0							207.7	2416	23374
68.0							214.2	2492	24108

7

OPERATION

Metric Calibration Chart

Mega-Cyl 800MP/HP

H ₂ O (IN)	Oxygen			Nitrogen			Argon		
	LITER	KG.	M ³	LITER	KG.	M ³	LITER	KG.	M ³
0.0	0.0	0.0	0.0	0.0	0.0	0.0	0.0	0.0	0.0
2.0	5.5	6	5	10.7	9	7	3.7	5	3
4.0	20.5	23	18	38.5	31	27	14.1	20	12
6.0	42.9	49	37	77.2	62	54	30.0	42	25
8.0	70.3	80	61	120.7	98	84	50.0	70	42
10.0	100.6	115	87	164.7	133	115	73.1	102	62
12.0	131.7	150	113	208.6	169	145	97.9	137	82
14.0	162.9	186	140	252.6	204	176	123.4	172	104
16.0	194.0	221	167	296.5	240	207	148.9	208	125
18.0	225.1	257	194	340.5	275	237	174.4	243	147
20.0	256.3	293	221	384.4	311	268	199.9	279	168
22.0	287.4	328	247	428.3	346	298	225.4	314	190
24.0	318.5	364	274	472.3	382	329	250.9	350	211
26.0	349.6	399	301	516.2	417	360	276.4	385	233
28.0	380.8	435	328	560.2	453	390	301.9	421	254
30.0	411.9	470	355	604.1	489	421	327.3	456	276
32.0	443.0	506	381	648.1	524	452	352.8	492	297
34.0	474.2	541	408	692.0	560	482	378.3	527	319
36.0	505.3	577	435	736.0	595	513	403.8	563	340
38.0	536.4	612	462	779.9	631	543	429.3	598	362
40.0	567.5	648	489	822.0	665	573	454.8	634	383
42.0	598.7	683	515				480.3	670	404
44.0	629.8	719	542				505.8	705	426
46.0	660.9	755	569				531.3	741	447
48.0	692.1	790	596				556.8	776	469
50.0	723.2	826	623				582.3	812	490
52.0	754.3	861	649				607.8	847	512
54.0	785.4	897	676				633.2	883	533
56.0	815.4	931	702				658.7	918	555
58.0							684.2	954	576
60.0							709.7	989	598
62.0							735.2	1025	619
64.0							760.7	1060	641
66.0							786.2	1096	662
68.0							810.8	1130	683

Problem	Probable Cause	Corrective Action
Mega-Cyl builds excessive pressure or builds pressure too fast.	Low usage.	If daily gas usage is under 100 SCF, the cylinder will build pressure. In liquid service, the cylinder should be equipped with low pressure relief valve and regulator.
	Cylinder is over filled.	If the cylinder is filled past the vent trycock or past the DOT specified fill weight, the pressure may rise rapidly after a fill.
	Pressure building regulator is set improperly or leaks.	If the pressure builds and stays at a pressure higher than desired, adjust the pressure building regulator to a new setting.
		If the pressure builds to the relief valve setting and the P.B. coil near the bottom of the tank is cold or frosted, replace the regulator.
	Vacuum is deteriorating.	This can be accompanied by cold or frost occurring evenly over the cylinder surface. Refer to the troubleshooting section on frost.
	Pressure builder valve is open.	Close valve.
Mega-Cyl pressure is too low.	Pressure building regulator is set too low.	Adjust the regulator as described on page 21.
	Pressure building regulator is not opening properly.	Bench test the regulator for full flow at the set pressure as described on page 21.
	Economizer regulator is set below the pressure building regulator setting.	The economizer regulator must be set 15-25 psi greater than the pressure building regulator as described on page 22.
	Usage is too high.	Refer to page 9 (Specifications) for maximum recommended delivery rates.
	Cylinder is leaking.	Check for frost on lines or on top of head. Listen for hissing, soap test joints for leaks. Isolate leak and call MVE for repair details.

8

TROUBLESHOOTING

Problem	Probable Cause	Corrective Action
Frost occurs around the circumference of the shell 4" to 8" from the bottom.	Cylinder is building pressure with the pressure building circuit.	This is normal if the cylinder pressure is lower than the pressure building regulator setting.
	Frost is residual from last fill or earlier use.	This is normal. A ring of ice or an oval shaped ice ball often remains on the cylinder for days after the last use or fill.
Frost occurs around the circumference of the shell 10" from the floor and up. Frost spot spirals up the shell.	Cylinder is vaporizing liquid into gas.	This is normal. The frost should melt within two hours after the gas use stops.
Frost occurs on head or knuckle.	Residual frost remains from last fill or recent product use.	This is normal. Ice may remain for days after a fill or heavy use.
Frost occurs evenly over the cylinder surface.	The gas withdrawal rate is high. Both the PB and gas use vaporizers are frosted.	This is normal.
	Cylinder has lost vacuum.	This is accompanied by high rate of pressure rise or high loss rate. Call MVE for return instructions.
Miscellaneous frost spots on cylinders.	Cylinder may have internal damage.	Call MVE for evaluation or repair/return instructions.
Delivery gas is too cold.	Rate exceeds recommended delivery rate.	Refer to page 9 (Specifications) for recommended maximum delivery rates.
In liquid delivery, liquid is mixed with high amount of gas.	Cylinder pressure is higher than optimum for liquid withdrawal.	Reset the cylinder pressure for liquid use. Also, use a phase separator on the end of the transfer hose.
In CO ₂ service, cylinder does not deliver product properly.	Possible dry ice blocks have formed in system.	Pressurize the cylinder to 100 psi or above to reliquefy from CO ₂ dry ice.

Adjusting Regulator Pressure Ranges

Use the following procedure to change the pressure range for either the pressure building or economizer regulator.

1. Remove the liquid product from the Mega-Cyl. Vent the cylinder of all pressure.
2. Remove the regulator from the cylinder.
3. Place the regulator body in a vise with the bonnet and adjusting screw pointed up.
4. Back out the adjusting screw until there is no spring pressure on it.
5. Carefully remove only the spring.
6. Replace the spring and reassemble.
7. Bench set the regulator as shown on page 21-22.

Bench Set-Up for Pressure Building Regulator

Figure 7

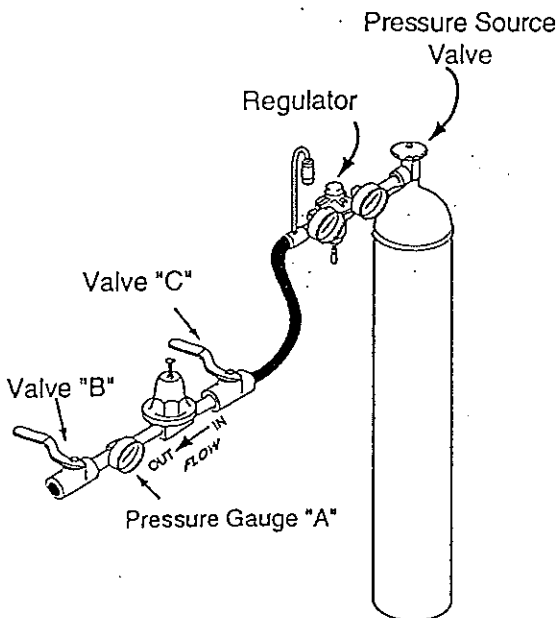

Alternate Regulator Springs			
Pressure Builder		Economizer	
Pressure (PSI)	Part No.	Pressure (PSI)	Part No.
2-25	57-1003-1	0-30	57-1024-1
15-65	57-1019-1	30-50	57-1021-1
40-100	57-1011-1	51-80	57-1015-1
100-250	57-1020-1	81-150	57-1016-1
		151-250	57-1034-1
		200-400	57-1030-1

Bench Setting a Pressure Building Regulator

1. Connect the pressure building regulator to a nitrogen pressure source as shown in Figure 7.
2. Close valve B.
3. Open the pressure source valve (follow appropriate safety rules).
4. Open valve C slowly.
5. Pressure gauge A will indicate the pressure to which the regulator has been set. The pressure can be increased by turning the adjusting screw in. The pressure may be decreased by turning the screw out; however, after each adjustment outward it will be necessary to open and then close valve B to relieve excess pressure.
6. This procedure may be repeated as many times as necessary to obtain the proper setting.
7. After the proper setting is obtained, secure the lock nut on the adjusting screw.

NOTE: Factory Setting:

Mega-Cyl 450/600/800 MP	125 psig
Mega-Cyl 450/600/800 HP	300 psig

Bench Setting an Economizer Regulator

1. Connect the inlet of the economizer regulator to a pressure source as shown in Figure 8.
2. Open the valve at the pressure source (follow appropriate safety rules).
3. Slowly open valve "B" just enough to allow some gas to escape.
4. Pressure gauge "A" will indicate the setting to which the economizer regulator is set. This setting may be increased by turning the adjusting screw in, or lowered by turning the adjusting screw out.
5. Gas will flow through the economizer regulator when the pressure of the gas reaches the pre-set setting.

NOTE: Factory Setting

Mega-Cyl 450/600/800 MP	140 psig
Mega-Cyl 450/600/800 HP	325 psig

Bench Set-Up for Economizer Regulator

Figure 8

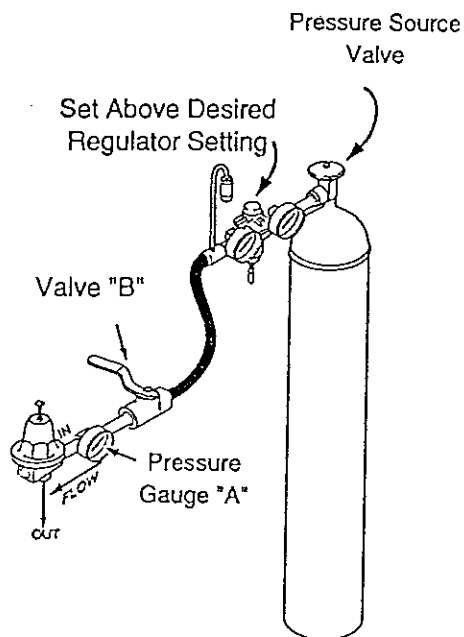

Rebuilding the Operational Valves

The valves that are used on the Mega-Cyls have a spring loaded rotary stem. This automatically compensates for thermal shrinkage and wear.

When a defective valve is suspected, follow this procedure to repair it, refer to Figure 9, page 23.

1. Open the vent valve and release any pressure that is in the container.
2. If the valve to be repaired is the vent valve, allow it to warm up before it is disassembled.
3. Before repairing any valve, the container should be emptied of product and pressure.
4. Remove the valve handle screw (Item 3), washer (Item 14), retainer cap and spring assembly (Items 2, 4, 8, 10 and 13).
5. Remove the valve handle (Item 1) and Teflon thrust washer (Item 7).
6. Unscrew bonnet (Item 5) to remove stem (Item 6) and stem seal.
7. Pick out body insert (Item 12) and plug assembly (Item 9).
8. Clean seat.
9. Replace parts as needed and reassemble in reverse order.

Globe Valve Components

Figure 9

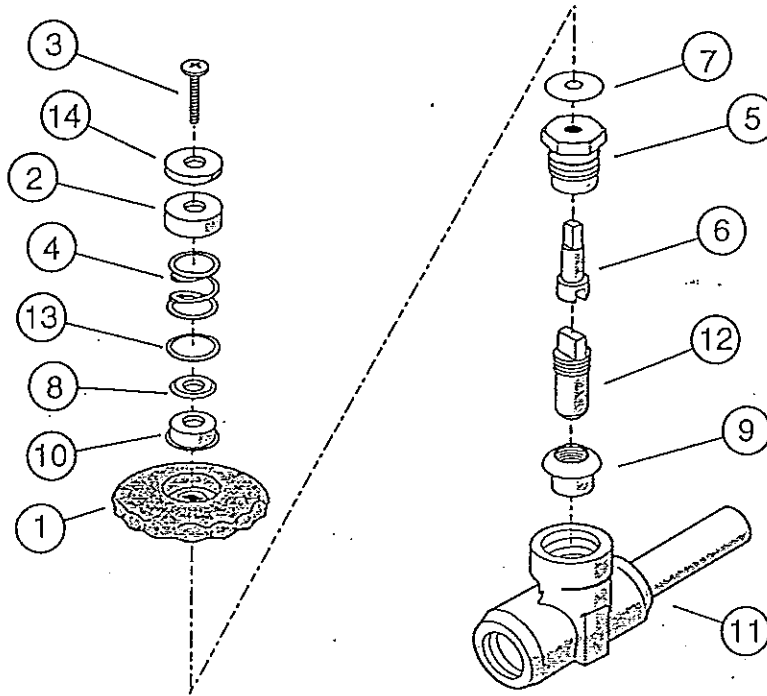

Item	Part No.	Qty.	Spares *	Description
1	17-1078-9	1	1	Handwheel
2	17-1086-9	1	1	Spring Retainer
3	17-1084-9	1	1	Screw
4	17-1077-9	1	1	Spring
5	17-1081-9	1	1	Bonnet
6	17-1089-9	1	1	Stem
7	17-1088-9	1	1	Gasket
8	17-1087-9	2	2	Washer
9	17-1082-9	1	1	Threaded Body Insert
10	17-1076-9	1	1	Seal
11	-	-	-	Body Assembly
12	17-1083-9	1	1	Seat and Nipple Assembly
13	17-1080-9	1	1	Washer
14	17-1085-9	1	1	Washer and Screw
-	97-1575-9	-	1	Valve Repair Kit (Includes items 1-14, except 11)

* Recommended spare parts

** Parts are also available in complete packages.

10

PARTS IDENTIFICATION

MEGA-CYL 450MP/HP

Figure 10

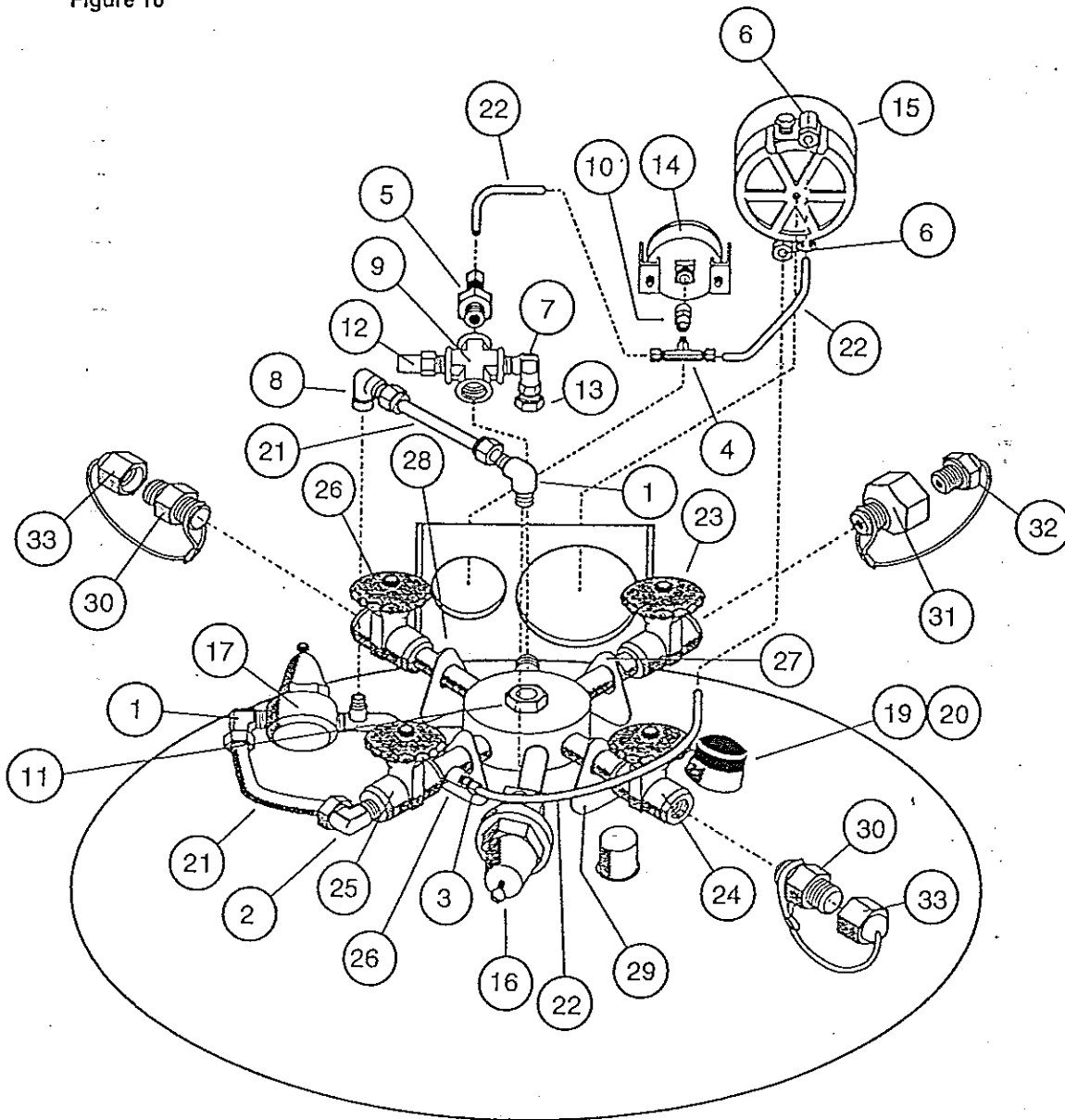

MEGA-CYL 450MP/HP

Item	Part No.	Qty	Description
1	10-1143-2	2	Elbow (3/8" ODT x 1/4" MPT)
2	10-1144-2	1	Elbow (3/8" ODT x 3/8" MPT)
3	10-1226-2	1	Brass Connector (1/8" ODT x 1/8" MPT)
4	10-1227-2	1	Brass Tee (1/8" ODT x 1/8" ODT x 1/8" MPT)
5	10-1282-2	1	Brass Connector (1/8" ODT x 1/4" MPT)
6	10-1360-2	2	Brass Elbow (1/8" ODT x 1/4" MPT)

PARTS IDENTIFICATION

10

MEGA-CYL 450MP/ HP (CONT.)

7	12-1046-2	1	Street Elbow Brass (1/4" MPT)
8	1012612	1	Brass Elbow (3/8" ODT x 1/4" FPT)
9	12-1292-2	1	Brass Cross (1/4" FPT)
10	12-1324-2	1	Brass Hex Coupling (1/8")
11	12-1365-1	1	SS Hex Head Plug (7/8" -14)
12	18-1216-2	1	Relief Valve(1/4" @ 250 psi)
12*	18-1046-2	1	Relief Valve (1/4" MPT @ 350 psi)(all except CO ₂)
13	19-1088-2	1	Rupture Disc (1/4" MPT @ 400 psi)
13*	19-1163-2	1	Rupture Disc (1/4" MPT @ 600 psi)
14	20-1383-9	1	Pressure Gauge (2-1/2" Dial x 1/8" CBM @ 0-400 psi)
14*	20-1397-9	1	Pressure Gauge (2-1/2" Dial x 1/8" CBM 0-600 psi)
15	20-1425-9	1	Differential Pressure Gauge (Dial 0-60")
16	21-1002-2	1	Economizer Regulator (1/4" NPT @ 140 psi)
16*	21-1075-2	1	Economizer Regulator (1/4" NPT @ 325 psi)
17	21-1003-2	1	Pressure Building Regulator (1/4" NPT @ 125 psi)
17*	21-1074-2	1	Pressure Building Regulator (1/4" NPT @ 300 psi)
18	38-1494-5	1	Warranty Seal (Rupture Disc Assembly)
19	39-1066-6	1	Cap (Blue Vinyl)
20	69-1061-3	1 ft	Tube (3/8" OD x .032" wall) Copper
21	69-1084-3	4 ft	Tube (1/8" OD) Copper
22	17-1002-2	1	Globe Valve (3/8" FPT) (Gas Use)
23	17-1599-2	1	Globe Valve (3/8" FPT) (Liquid Fill)(Blue)
24	17-1002-2	1	Globe Valve (3/8" FPT) (Pressure Building) (Green)
25	17-1001-2	1	Globe Valve (3/8" FPT) (Vent) (Silver)
26	38-1161-9	1	Metal Tag (Pressure Building)
27	38-1159-9	1	Metal Tag (Gas Use)
28	38-1160-9	1	Metal Tag (Vent)
29	31-1158-9	1	Metal Tag (Liquid)

ALL MODELS

Item	Part No.	Qty	Description
30	11-1007-2	2	Male Connector (1/2" ODT x 3/8" MPT) (Argon or Nitrogen)
30	11-1011-2	2	Male Connector (5/8" ODT x 3/8" MPT) (Oxygen)
30	11-1007-2	1	Male Connector (1/2" ODT x 3/8" MPT) (CO ₂)
30	11-1007-2	1	Male Connector (1/2" ODT x 3/8" MPT) (N ₂ O)
31	40-1002-2	1	Gas Outlet (3/8" MPT XCGA-580) (Argon or Nitrogen)
31	40-1001-2	1	Gas Outlet (3/8" MPT XCGA-540) (Oxygen)
31	40-1056-2	2	Gas & Liquid Connection (3/8" MPT XCGA-320) (CO ₂)
31	40-1060-2	2	Gas & Liquid Connection (3/8" MPT XCGA-326) (N ₂ O)
32	40-1062-9	1	Dust Cap (Argon or Nitrogen)(Gas Use)
32	40-1051-2	1	Dust Cap (Oxygen)(Gas Use)
32	40-1666-9	2	Dust Cap -CGA- 320 (CO ₂)
32	40-1025-2	2	Dust Cap -CGA-326 (N ₂ O)
33	40-1663-9	2	Dust Cap (1/2" ODT) (Argon or Nitrogen)
33	40-1664-9	2	Dust Cap (5/8" ODT) (Oxygen)

* These components used on HP models only

10 PARTS IDENTIFICATION

MEGA-CYL 600MP AND 800MP

Figure 11

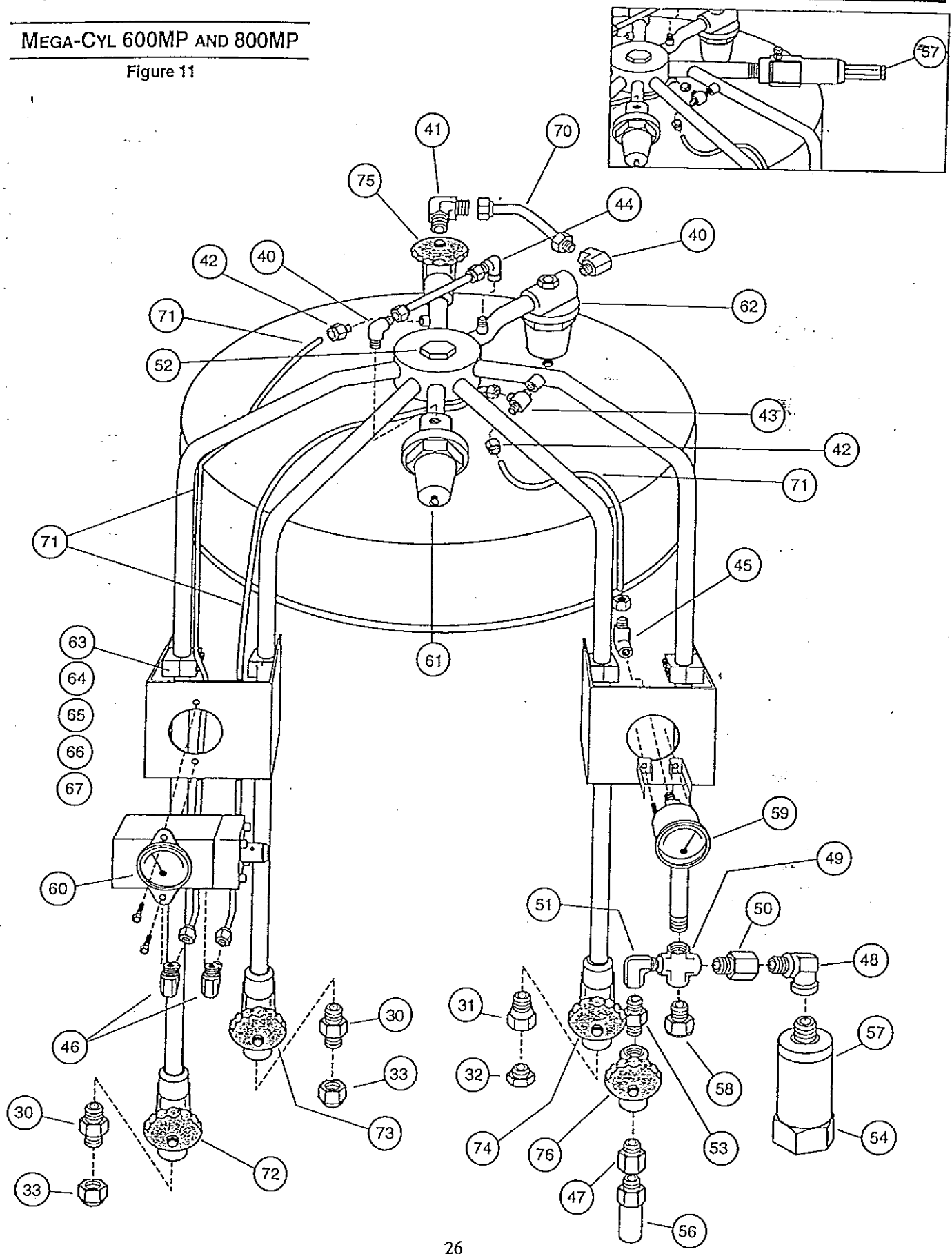

PARTS IDENTIFICATION

10

MEGA-CYL 600MP/HP AND 800MP/HP

Item	Part No.	Qty	Description
40	10-1143-2	2	Elbow (3/8" ODT x 1/4" MPT)
41	10-1144-2	1	Elbow (3/8" ODT x 3/8" MPT)
42	10-1226-2	1	Brass Connector (1/8" ODT x 1/8" MPT)
43	10-1227-2	1	Brass Tee (1/8" ODT x 1/8" ODT x 1/8" MPT)
44	10-1261-2	1	Elbow (3/8" ODT x 1/4" FPT)
45	10-1349-2	1	Brass Elbow (1/8" OD x 1/4" FPT)
46	10-1360-2	2	Brass Elbow (1/8" OD x 1/4" MPT)
47	12-1002-2	1	Hex Bushing (1/4" FPT x 3/8" MPT)
48	12-1050-2	1	Street Elbow (1/2" MPT)
49	12-1095-2	1	Brass Cross (3/8" FPT)
50	12-1116-2	2	Adapter (1/2" FPT x 3/8" MPT)
51	12-1319-2	1	Elbow (3/8" MPT x 3/8" FPT)
52	12-1326-1	1	Plug (3/4"-16 Hex Head)
53	13-1198-2	1	Nipple Hex (3/8")
54	16-1162-2	1	Adapter (1/2" FPT)
56	18-1001-2	1	Relief Valve (1/4" MPT @ 22 psi)
57	18-1236-2	1	Relief Valve (1/2" MPT @ 250 psi)
57	18-1146-2	1	Relief Valve (3/4" FPT @ 350 psi)(Old Style)
57*	10746447	1	Relief Valve (1/2" MPT @ 350 psi)(Oxygen, Argon,Nitrogen)
58	19-1173-2	1	Burst Disc (400 psi)
58*	19-1148-2	1	Burst Disc (450 psi)
59	20-1383-9	1	Pressure Gauge (2-1/2" Dial x 1/8" CBM @ 0-400 psi)
59*	20-1397-9	1	Pressure Gauge (2-1/2" Dial x 1/8" CBM @ 0-600 psi)
60	20-1433-9	1	Differential Pressure Gauge – Max Serv. Press 1500 psi
61	21-1002-2	1	Economizer Regulator (1/4" NPT @ 140 psi))
61*	21-1075-2	1	Economizer Regulator (1/4" NPT @ 325 psi)
62	21-1003-2	1	Pressure Building Regulator (1/4" NPT @ 125 psi)
62*	21-1074-2	1	Pressure Building Regulator (1/4" NPT @ 300 psi)
63	29-1059-1	16	Flat Washer (1/4")
64	29-1060-1	16	Split Lock Washer (1/4")
65	29-1067-1	16	Hex Nut (1/4"-20)
66	29-1403-1	16	Hex Bolt (1/4"-20 x 1-3/4" long)
67	34-1163-6	16	Clamp (5/8" OD Tube)
68	38-1494-5	1	Warranty Seal
69	39-1066-6	1	Blue Vinyl Cap
70	69-1061-3	1 ft	Tube (3/8" OD x .032" wall) Copper
71	69-1084-3	4 ft	Tube (1/8") Copper
72	17-1001-2	1	Globe Valve (3/8")(Vent)(Silver)
73	17-1599-2	1	Globe Valve (3/8")(Liquid)(Blue)
74	17-1002-2	1	Globe Valve (3/8")(Gas)
75	17-1002-2	1	Globe Valve (3/8")(Pressure Building)(Green)
76	17-1739-2	1	Globe Valve (3/8") Road Relief isolation
-	38-3058-9	1	Decal (Pressure Building)
-	38-3059-9	1	Decal (Liquid Valve)
-	38-3060-9	1	Decal (Use Valve)
-	38-3061-9	1	Decal (Vent Valve)

* These components used on HP models only.
 ** Used on A models only.

MVE, Inc.
8011 34th Avenue South
Bloomington, MN 55425