



**SeQual Technologies Inc.**

11436 Sorrento Valley Road, San Diego CA 92121 USA • 858-558-0202 • Fax 858-558-1915

# **Workhorse-15 Oxygen Generator**

**Model No.**  
**5719, 5727, 5735**

**Product Documentation Package**  
**for**  
**Domestic and International Units**

Part number 1432 Revision D

## **Cautions, Warnings and Hazards**

Oxygen is a powerful oxidizing agent. It can cause fire or explosion. Observe strict cleanliness procedures when fabricating and connecting the oxygen piping. ***It is imperative that oxygen systems be properly cleaned and inspected to insure that no combustible materials remain in the connecting piping and fittings.*** Do not allow the free flow of oxygen from the Workhorse Oxygen Generator or from any point on the oxygen manifold.

Ensure that the Workhorse Oxygen Generator is in a well ventilated area. If the space is occupied, sufficient ventilation must be provided to prevent the accumulation of low oxygen concentration waste gas in the space. Approximately 6 air changes per hour are necessary.

Do not allow rain or condensation to contact the Workhorse Oxygen Generator. The Workhorse Oxygen Generator is not weather proof. It must be operated indoors or in an enclosure in a noncondensing environment.

The Workhorse Oxygen Generator should be installed and operated per the Compressed Gas Association Guide P-8.1 "Safe Installation and Operation of PSA and Membrane Oxygen and Nitrogen Generators."

## **Patents, Trademarks and Copyright**

The Workhorse Oxygen Generator is protected by the following US Patents:  
4,925,464    5,112,367    5,114,441    5,268,021    5,366,541    5,593,478  
5,730,778    Re. 35,099    Other patents pending.

ATF® and SeQual® are registered trademarks of SeQual Technologies Inc.

© Copyright SeQual Technologies Inc. 1999

## **Table of Contents**

	Page
Cautions, Warnings and Hazards	2
Patents, Copyrights and Trademarks	2
Introduction	4
Installation	4
Operation	5
Maintenance	6
Specifications	6
Mechanical Outline Drawing	7
Service Parts	8
How to Contact SeQual	8

## **Introduction**

The operation of the Workhorse Oxygen Generator is based on the pressure swing adsorption (PSA) cycle using synthetic zeolite molecular sieve. The Workhorse Oxygen Generator is capable of delivering oxygen flows up to 15 standard cubic feet per hour (SCFH) at over 90% by volume oxygen concentration at rated conditions. The main components of the Workhorse Oxygen Generator are a SeQual ATF Oxygen Concentrator Module and an oilless air compressor.

Typical applications for the Workhorse Oxygen Generator include aquaculture and feed gas for ozone generation. SeQual can supply oxygen generators, sub-systems and components for generators in many capacities. See our website at [www.sequal.com](http://www.sequal.com).

## **Installation**

**IMPORTANT:** There are packaging materials that must be removed from under and around the compressor. Do not attempt to operate the Workhorse Oxygen Generator without removing these packaging materials as damage may result.

Ensure that there is sufficient access space around the Workhorse Oxygen Generator so that normal maintenance and service can be performed. Also ensure that there will be a free flow of cooling air around the compressor. Connect the unit to a grounded power source rated for the voltage and current requirements stated on the label on the unit.

**IMPORTANT:** The location of the Workhorse Oxygen Generator must be well ventilated. Refer to the recommendations in the Compressed Gas Association Guide P-8.1 “Safe Installation and Operation of PSA and Membrane Oxygen and Nitrogen Generators.” Contact SeQual if further assistance is needed.

**IMPORTANT:** Choose a location for the Workhorse Oxygen Generator that does not allow rain or condensation to contact the unit. The Workhorse Oxygen Generator is not weather proof. It must be operated indoors or in an enclosure in a noncondensing environment.

### **Oxygen Hook-up**

The oxygen outlet connection is 1/8 inch female National Standard Pipe Thread (NPT) and is located on the front of the Workhorse Oxygen Generator. The hex nut bulkhead fitting should be stabilized with a 7/8 inch wrench to prevent rotation when making your connection to the unit.

**IMPORTANT:** Oxygen is a powerful oxidizing agent. It can cause fire or explosion. Observe strict cleanliness procedures when fabricating and connecting the oxygen piping. *It is imperative that oxygen systems be properly cleaned and inspected to insure that no*

***combustible materials remain in the connecting pipe and fittings.*** If you are not familiar with oxygen cleaning procedures, refer to the Compressed Gas Association documents G-4.1 “Cleaning Equipment for Oxygen Service” and G-4.4 “Industrial Practices for Gaseous Oxygen Transmission and Distribution Piping Systems.”

**IMPORTANT:** Do not allow the free flow of oxygen from the Workhorse Oxygen Generator. Ensure that the oxygen flow is measured and controlled to rates that do not exceed rated capacity.

## **Operation**

If the Workhorse Oxygen Generator is supplied with a cover, make certain the fan cord is connected to the fan on the cover, before reinstalling the cover. The length of the cord provides for cover removal without disconnecting the cord from the fan.

To start the Workhorse Oxygen Generator, connect the unit to a grounded power source rated for the voltage and current requirements stated on the label on the unit. Push the toggle switch on the front panel to the up position. [The green LED on the front panel of the unit will light, indicating that power is applied to the system, and the red LED will light indicating low oxygen concentration.]

Set the outlet oxygen flow to 15 SCFH (7 SLPM) or less. [When the oxygen concentration achieves 70% the red LED will go out and a yellow LED will light. When the concentration is greater than 85%, the yellow LED will go out.]

[The visual LED alarms also correspond to two alarm outputs on the nine pin D-sub connector located under the LEDs. These outputs are Form A one amp dry contacts. They are normally open and close during an alarm. Only one contact is closed at any time during an alarm. If the oxygen concentration falls below 85%, the yellow LED will light and pins 4 and 5 will close. If the concentration falls below 70%, these contacts will open and the yellow LED will turn off. The red LED will then light and pins 2 and 3 will close.]

[Pins 1 and 6 can be used to measure the concentration level to within  $\pm 2\%$  of concentration. This is read by placing the negative lead of a digital voltmeter on pin 1 and the positive lead on pin 6. A 0-1 volt output is displayed with one volt relating to 100% and zero volts relating to 0%. Audible and visual alarms, automatic phone dialers and digital oxygen purity displays that directly interface with the nine pin connector are available as accessories. Contact SeQual Customer Service for additional information.]

[ ] **Applies to models with optional oxygen monitor.**

**IMPORTANT:** Ensure that the Workhorse Oxygen Generator is in a well ventilated area. If the space is occupied, sufficient ventilation must be provided to prevent the

accumulation of low oxygen concentration waste gas in the space. Approximately 6 air changes per hour are necessary.

**IMPORTANT:** The flow meter installed on the Workhorse Generator is set to read accurately when the discharge is to atmospheric pressure. If the actual discharge pressure is substantially above atmospheric pressure, the reading can be adjusted to determine the precise flow rate, according to the following formula:

$$(\text{adjusted flow}) = (\text{measured flow}) \times \sqrt{\frac{\text{oxygen pressure} + 14.7}{14.7}} . \text{ Please contact SeQual}$$

Technical Support if additional assistance is required.

Do not allow the oxygen product to vent freely. Do not exceed rated capacity.

## **Maintenance**

The Compressor Inlet Filter should be changed every 4,000 hours. Filter change frequency is dependent on environmental conditions and may vary.

Compressors require a rebuild after 5,000 to 12,000 hours of operation, depending on environmental conditions.

See the Service Parts section for information on replacement air inlet filters and compressor rebuild kits.

## **Specifications**

### Compressed Air

Pressure Relief Valve setting: 35 psig ±10%

### Oxygen Output

15 SCFH (7 SLPM) at 90% +3%/-5% oxygen by volume at 5 psig minimum (at lab conditions, derated performance at higher temperature and humidity)

1/8" NPT Female Pipe connection

### Electrical Input

120 VAC, single phase, 60 Hz, 5.4 Amps, 450 W

230 VAC, single phase, 60 Hz, 2.5 Amps, 450 W

220/240 VAC, single phase, 50 Hz, 2.5 Amps, 450 W

### Environment

Generator is not weather proof. It must be operated indoors or in an enclosure in a noncondensing environment. If the space is occupied, sufficient ventilation must be provided to prevent the accumulation of low oxygen concentration waste gas in the space.

Temperature (Operating): 40°F to 110°F

Temperature (Storage): -20°F to 170°F

Humidity: 0 to 95% RH

Barometric Pressure Range: 28 to 31 inches of Hg

Ambient Oxygen Concentration: 20.0% minimum

### Operation

Unit should be installed and operated per the Compressed Gas Association Guide P-8.1 “Safe Installation and Operation of PSA and Membrane Oxygen and Nitrogen Generators.”

### Mechanical

Maximum Dimensions: 21.75"H x 17"W x 14"D

Weight: 48 lb.

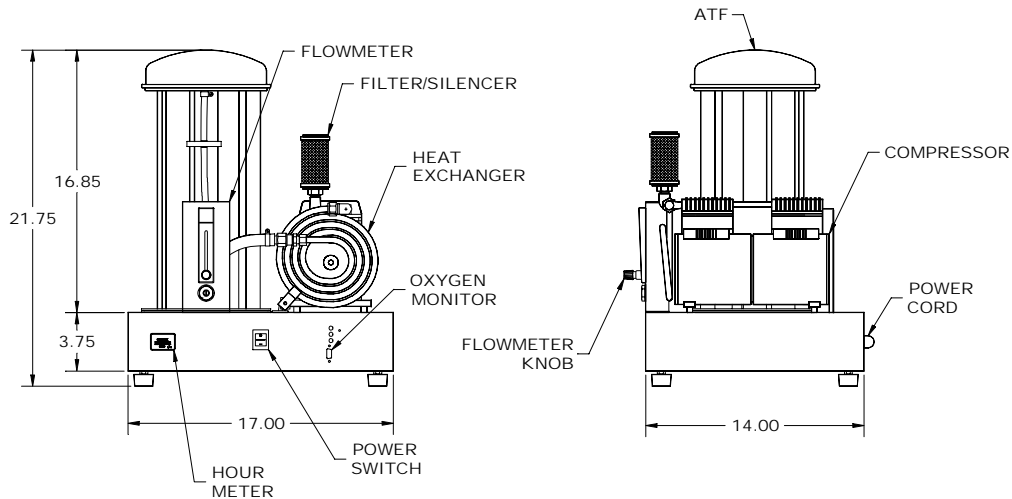

## **Service Parts**

Service parts listed below can be obtained directly from SeQual. Hose can generally be obtained locally; specifications are listed below. Always replace hoses with equal or better specifications. Other parts are not considered regular service items. Please contact SeQual directly for further information on other parts.

### Service Parts

Service Part	SeQual P/N	Quantity Used
ATF Module 120 VAC	1245	1
ATF Module 220/240 VAC 50/60Hz	1498	1
Compressor 120 VAC	3110	1
Compressor Rebuild Kit 120 VAC 60Hz	3197	1
Compressor 220/240 VAC 50/60Hz	1314	1
Compressor Rebuild Kit 220/240 VAC 50/60Hz	1357	1
Compressor Inlet Filter	1407	1
Pressure Relief Valve	1368	1
Vibration Mount	1367	4

### Replacement Hose

Hose Size (ID x OD)	Construction	Working psi at 70°F	Temperature Range (°F)
1/2" x 7/8"	Reinforced silicone	141	-40 to 175
1/4" x 1/2"	PVC	70	-40 to 175

## **How to Contact SeQual**

By mail:

SeQual Technologies, Inc.  
11436 Sorrento Valley Road  
San Diego, CA 92121 USA

By telephone:

858-558-0202 or toll-free in the United States at 1-800-826-4610

By facsimile:

858-558-1915

By E-mail:

techsupport@sequal.com