



Chart SeQual Technologies, Inc.

**Model 5130, 5132 & 5134
130 SCFH
ATF[®] Oxygen Subsystem**

Product Documentation Package

**Part Number 3317
Revision C**

Cautions, Warnings and Hazards

Oxygen is a powerful oxidizing agent. It can cause fire or explosion. Observe strict cleanliness procedures when fabricating and connecting the oxygen piping. ***It is imperative that oxygen systems be properly cleaned and inspected to insure that no combustible materials remain in the system.*** Do not allow the free flow of oxygen from any ATF module or from any point on the oxygen manifolding.

Do not apply air without power to the Oxygen Generator System. The Oxygen Generator System must be powered up when air is turned on. Do not apply more than 35 psig air pressure to the inlet manifold. The Oxygen Generator System is protected with a 50 psig relief valve on the inlet manifold.

Do not allow rain or condensation to contact the Oxygen Generator System. The Oxygen Generator System is not weather proof. It must be operated inside or in an enclosure in a noncondensing environment. The ATFs require clean, dry air.

The Oxygen Generator System should be installed and operated per the Compressed Gas Association Guide P-8.1--1995 "Safe Installation and Operation of PSA and Membrane Oxygen and Nitrogen Generators."

If not already provided, connect an earth ground wire of suitable size, according to local regulations, to the electrical enclosure.

Patents, Trademarks and Copyright

The Oxygen Generator System is protected by the following US Patents:

4,925,464 5,112,367 5,114,441 5,268,021 5,366,541 5,593,478
5,730,778 Re. 35,099 Other patents pending

ATF[®] and SeQual[®] are registered trademarks of Chart SeQual Technologies Inc.

Copyright © 2012 Chart Industries

Table of Contents

Cautions, Warnings and Hazards.....	2
Patents, Trademarks and Copyright.....	2
Table of Contents	3
Introduction.....	4
Installation.....	4
Operation.....	5
Maintenance	6
Troubleshooting	6
Specifications	8
Mechanical outline drawing.....	10
Service Parts.....	10
How to Contact SeQual	12

Introduction

Operation of the Oxygen Generator System is based on the pressure swing adsorption (PSA) cycle using synthetic zeolite molecular sieve. This 130 SCFH unit consists of four ATF oxygen modules installed on a quad base configured into a manifolded unit for air input and oxygen output.

There are four LEDs on the front panel of the quad base. The green LED is on as long as power is supplied to the System. The yellow LED is on when the concentration is between 70 and 85%. Lower than 70% concentration, the yellow LED turns off and the bottom red LED turns on. When the yellow LED is on, pins 4 and 5 on the DB-9 connector are closed. When the red is on pins 2 and 3 are closed.

The oxygen outlet solenoid valve does not open until the outlet manifold pressure achieves 10 psig. It closes if the pressure drops below 6 psig. When this occurs, the top red LED will light and oxygen flow will stop.

The air inlet solenoid valve opens immediately upon power up. If the unit does not achieve concentration greater than 70% for more than five minutes, this valve will close. This action will cause the oxygen outlet flow to go to zero since no air is flowing in. The oxygen manifold pressure switch will then drop below its 6 psig threshold, thus closing the outlet valve and turning on the top red LED. With no flow, the concentration will drop below the 85% margin and the yellow LED alarm will come on, closing pins 4 and 5 on the DB-9 connector.

The system must be powered down and back up in order to reset the alarms.

Installation

IMPORTANT: There are internal packaging materials that must be removed from the unit. Do not attempt to operate the Oxygen Generator System without removing these packaging materials.

Moving and Locating

Ensure that there is sufficient access space around the Oxygen Generator System so that service can be performed.

IMPORTANT: The location of the Oxygen Generator System must be well ventilated to prevent suffocation of personnel.

Refer to the recommendations in the Compressed Gas Association Guide P-8.1--1995 "Safe Installation and Operation of PSA and Membrane Oxygen and Nitrogen Generators."

IMPORTANT: Choose a location for the Oxygen Generator System that does not allow rain or condensation to contact the unit.

Electrical Hookup

Connect the Oxygen Subsystem power cord to a grounded AC power source, according to the rating on the label.

Air Hookup

The air connection is made using 3/4" ID hose from the compressor outlet fitting to the Oxygen Subsystem inlet fitting.

Best practice recommends the use of a coalescing filter immediately upstream of the Quad in the air line, to remove any liquid water droplets that may have condensed in the tubing or piping since the last water trap or dryer. A filter is supplied with the Quad for this purpose. Ideal location is slightly below the Quad, if possible. Note that some piping runs may require additional filtration if the conditions are such that more liquid water is condensing than the filter can adequately remove from the air stream.

IMPORTANT: The inlet air temperature to the sub system must not exceed 170° F. The air pressure must not exceed 40 psig.

Oxygen Hookup

Remove the cap covering the oxygen output only when you are ready to connect the Oxygen Generator System to your system. This is a 1/8" female pipe thread. Be sure to support the bulkhead fitting when installing your connection.

IMPORTANT: Oxygen is a powerful oxidizing agent. It can cause fire or explosion. Observe strict cleanliness procedures when fabricating and connecting the oxygen piping. If you are not familiar with oxygen cleaning procedures, refer to the Compressed Gas Association documents G-4.1--1985 "Cleaning Equipment for Oxygen Service" and G-4.4 "Industrial Practices for Gaseous Oxygen Transmission and Distribution Piping Systems."

Operation

Startup

Before activating the System, verify all of the connections are installed as described in the previous section. Ensure that the air supply pressure is between 30 and 40 psig for proper operation.

IMPORTANT: The inlet air temperature must not exceed 170 °F. The air pressure must not exceed 40 psig.

After the outlet solenoid valve opens (the outlet manifold gauge will read above 10 psi) open the flow meter valve and set the outlet oxygen flow. If the flow meter valve is opened prior to the solenoid valve opening, the violent inrush of oxygen flow could damage the flow meter. Allow at least fifteen minutes for the system to stabilize. Check all connections for leaks while the System is warming up. If, after fifteen minutes, the System is not producing the correct amount of oxygen, check the troubleshooting sections on the following pages.

IMPORTANT: Do not allow the oxygen product to vent freely. Do not exceed rated capacity. It is highly recommended that an accurate flow meter be fitted to the oxygen outlet in order to monitor the flow from the Oxygen Generator System. This is supplied with the System.

Oxygen Monitor

Once the system is turned on, the green LED on the front panel should be lit. During the fifteen minute warm-up time, you will see the oxygen monitor LEDs on the front panel turn from red to yellow. The red LED will be on when the concentration is below 70%. When the concentration is above 70%, the red LED will turn off and the yellow LED will turn on. The yellow LED will turn off when concentration is above 85%.

There is a DB-9 connector under the LED's. Pins 2 and 3 correspond to the red LED alarm with a contact closure. Pins 4 and 5 correspond to the yellow LED alarm, also with a contact closure. The relay contacts are rated at one amp 120 VAC. Pins 1 and 6 supply a 0-1 volt dc level, which relates to the oxygen concentration. Zero volts corresponds to 0% and 1 volt corresponds to 100% concentration. Pin 1 is the reference.

Maintenance

There is no scheduled maintenance required on the ATF Oxygen Modules. The solenoid valves will need scheduled rebuilding depending on environmental conditions and use.

Troubleshooting

Equipment

Special equipment required for troubleshooting and repairing the Oxygen Generator System includes:

Portable Oxygen Analyzer (MSA Miniox I Analyzer, P/N 473030), or equivalent
Available from: Mine Safety Appliance (MSA)
P.O. Box 426
Pittsburgh, PA 15230 USA
(800) 672-2222

Flow meter with needle valve that measures 50 SCFH

Pressure gauge that measures 0 to 30 psig (0 to 60 psig is necessary if measuring the pressure of the input air pressure rather than the output oxygen, or if measuring both)

General Troubleshooting Procedure

Before starting the troubleshooting procedure on individual ATF modules, ensure the electrical, air and oxygen connections to the Oxygen Generator System are adequate and functional. Determine first if the applied power is within specification and that no fuses are open. Next determine if the required air quality, pressure and flow are met. Finally, inspect the oxygen connection to determine that there are no leaks or excessive flow rates. If the system appears to be operating normally but oxygen concentration or pressure is not within specifications, then follow this procedure.

Verify the oxygen flow from the system is within specifications for your model. Use an accurate flow meter that is calibrated or corrected for the oxygen concentration, temperature and pressure of the stream. Using an air flow meter can result in errors of more than 6%.

Check for leaks in the oxygen piping upstream of the flow meter. Use Snoop[®] Liquid Leak Detector (Nupro, Willoughby, OH) or an equivalent leak test liquid. Check all joints and fittings starting at the oxygen ports of the ATF Modules and working towards the flow meter location.

Verify that the motor of each ATF Module is rotating (best done by marking the visible end of the shaft).

Verify that the compressed air pressure is between 35 and 40 psig (use an accurate gauge). Check for leaks in the air piping. Use Snoop[®] Liquid Leak Detector (Nupro, Willoughby, OH) or an equivalent leak test liquid. Check all joints and fittings starting at the air inlet ports of the ATF Modules and working back towards the air supply. Check the pressure relief valve as well.

Check filters. Shut off the system to inspect any filter fitted on the system. Inspect the filter element and replace if it appears obstructed.

Verify the ambient conditions are within specification. These include the temperature (40 to 110°F) and barometric pressure (28 to 31 in Hg). Ensure the oxygen levels in the space surrounding the system are not reduced (must be at least 20.0%).

If none of the above items corrected the situation, the individual ATF Modules must be checked for performance. Refer to the section below titled ATF Module Testing.

ATF Module Testing

To determine if an ATF module has failed, first turn off the Oxygen Generator System. Remove the oxygen outlet tube from the ATF module. Connect the ATF module oxygen outlet to 50 SCFH flow meter, pressure gauge and oxygen analyzer as shown in the following diagram. Plug the now disconnected tube leading to the oxygen manifold on the Oxygen Generator System to prevent the backflow of oxygen out the disconnected tube.

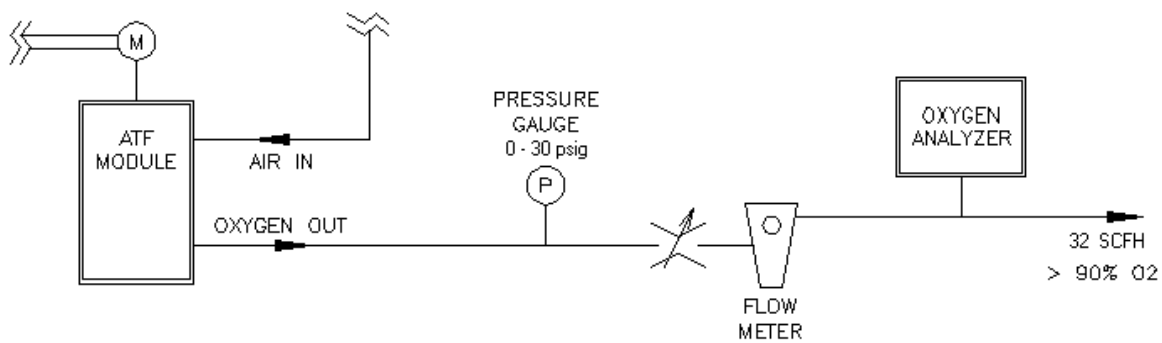

Diagnostic Test Setup for ATF Module

Power on the Oxygen Generator System. Allow at least 15 minutes for pressures and concentrations to stabilize. The air pressure applied to the ATF Module should be between 35 and 40 psig. The oxygen pressure from the ATF module should be at least 15 psig with an oxygen flow of 32 SCFH. The oxygen concentration should be 90% + 3% at this same flow. If the air pressure is within specification and either the oxygen concentration or pressure is not in specification, replace the ATF Module. If the concentration and pressure are within specification, repeat the test on the other three ATF Modules located in the ATF Unit. If the air pressure is not within specification, the cause must be determined and remedied prior to testing individual ATF Modules for function.

Specifications

Compressed Air

1/2" Female NPT or 3/4" hose barb inlet connection
 40 psig maximum outlet air pressure
 120°F maximum outlet air temperature
 Water load equivalent to saturated air at 120°F at 30 psig acceptable
 No liquid water

24 SCFM at 35 psig minimum

Oxygen Output

1/4" Female NPT

130 SCFH at 90% + 3% oxygen by volume at 15 psig
 Oxygen concentration performance rated at 120°F inlet air temperature

Electrical Input

120 VAC, single phase, 60 Hz, 400 mA

208-240 VAC, single phase, 60 Hz, 200 mA

Environment

The System is not weather proof. It must be operated inside or in an enclosure in a noncondensing environment. If the space is occupied, sufficient ventilation must be provided to prevent the accumulation of low oxygen concentration waste gas in the space. Approximately 6 air changes per hour are necessary.

Temperature (Operating): 40°F to 110°F

Temperature (Storage): -20°F to 170°F

Humidity: 0 to 95% RH

Barometric Pressure Range: 28 to 31 inches of Hg

Ambient Oxygen Concentration: 20.0% minimum

Operation

Unit should be installed and operated per the Compressed Gas Association Guide P-8.1--1995 "Safe Installation and Operation of PSA and Membrane Oxygen and Nitrogen Generators."

Mechanical

Maximum Dimensions of Oxygen Subsystem: 20.5"H x 21"W x 21"D

Weight: 97 lb.

Mechanical outline drawing

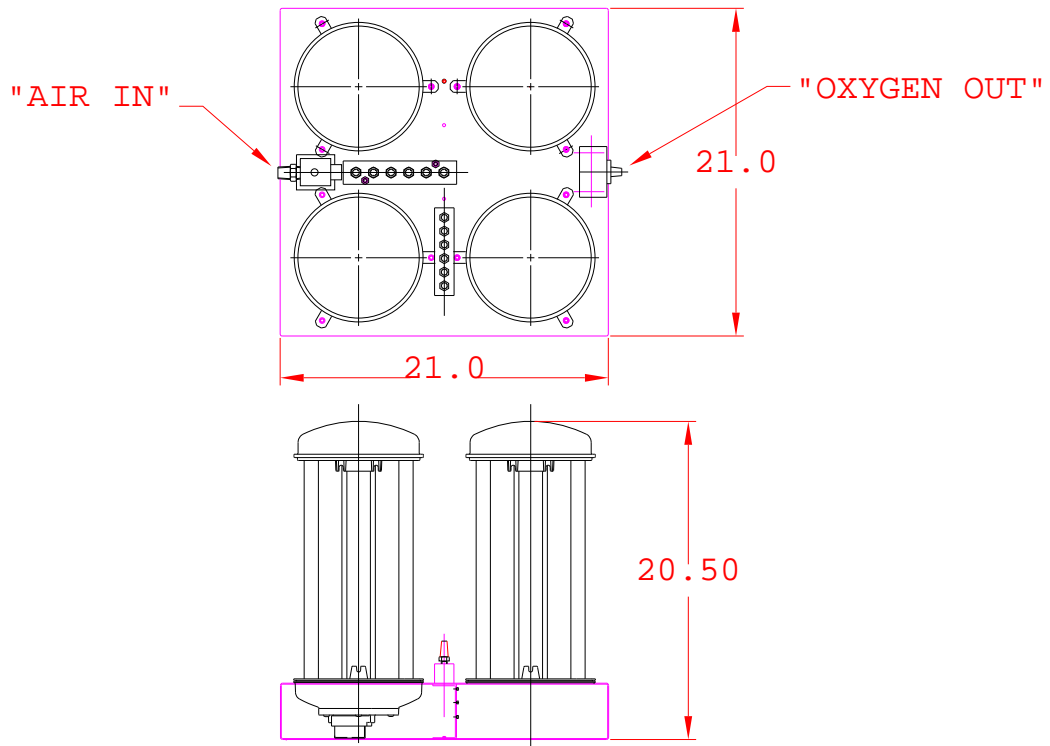

Service Parts

Service parts listed below can be obtained directly from SeQual. Tubing can generally be obtained locally; specifications are listed below. Always replace tubing with equal or better specifications. Other parts are not considered regular service items. Please contact SeQual directly for further information on other parts.

Service Parts

Service Part Description	SeQual Part Number	Quantity Used
Model 5130 ATF Modules	3328V	4
Model 5132 ATF Modules	3328V	4
Model 5134 ATF Modules	4104V	4
Air Inlet Solenoid Valve	Call	1
Oxygen Outlet Solenoid Valve	Call	1
Solenoid Coils	Call	2
Air Pressure Gauge	1330	1
Oxygen Pressure Gauge	1331	1
Oxygen monitor	Call	1

Replacement Tubing

Tube Size (ID x OD)	Construction	Max. Working Pressure (psi)	Temperature Range (°F)
3/4" x 1"	Braided PVC	300	-20 to 200
1/2" x 3/4"	Braided PVC	250	-20 to 200
1/4" x 1/2"	PVC	70	-40 to 175

How to Contact SeQual

By mail:

Chart SeQual Technologies
2200 Airport Industrial Drive, Suite 500
Ball Ground, GA 30107

By telephone:

770-721-7759 or toll-free in the United States at 1-800-482-2473

By Fax:

888-932-2473

By E-mail:

Customerservice.usa@chartindustries.com