



## UltraDoser<sup>®</sup> Liquid Nitrogen Dosing

The UltraDoser<sup>®</sup> is the multi-purpose liquid nitrogen (LN<sub>2</sub>) dosing system utilizing advanced cryogenic technology and PLC programming.

Chart engineers designed an ultra-efficient system for low to medium production line speeds to dispense a precise dose of LN<sub>2</sub> into every container every time. The LN<sub>2</sub> gasifies and is either trapped in the container to add rigidity or escapes with oxygen to inert the headspace.

### Features

- **Compact Size** – enables installation in limited spaces
- **Precise Dosing** – delivers consistent, accurate dosing
- **Discrete Dosing\*** – up to 2000 containers per minute
- **Discrete or Continuous Dosing** – change over defined by user
- **SoftDose™ Compatible** – Chart's proven technology for hot fill, powder, and granular applications
- **RemoteDose™ Capable\*** – monitor and troubleshoot the system remotely thereby minimizing or eliminating system downtime\*\*
- **MicroDose™ Capable** – designed specifically for tight pressure specifications
- **IntelliDose™ Capable** – automatic dose adjustments at any line speed between low/high points as defined by user
- **Warranty** – two (2) year warranty against manufacturing defects from time of shipment

\* When paired with the 2K controller. Results achieved at Chart laboratory conditions.

\*\* Access to the internal network is necessary for this function.



### How it Works

LN<sub>2</sub> is supplied to the UltraDoser by a vacuum insulated hose and flows into the dosing head. A sensor detects the speed of the line (encoder compatible); a second sensor detects the presence of a container. When a container is detected, the dosing head opens and dispenses an exact amount of pure LN<sub>2</sub>. A PLC (Programmable Logic Controller) is the brains behind integrating the sensors, controls and human interface.

### Key Benefits

- **Lightweight PET** – reduce the weight of PET for cost and environmental savings
- **Glass to PET Transition** – eliminate glass safety hazards and weight of containers
- **Bottle Rigidity** – maintain bottle shape even with lighter weight containers
- **Eliminate Paneling** – increase the internal pressure to offset paneling issues
- **Oxygen Reduction** – create an inert environment to preserve product freshness
- **Extend Shelf Life** – minimize oxygen levels
- **Ease of Labeling** – consistent bottle rigidity creates an efficient labeling process
- **Reduce Nitrogen Consumption** – measurable and repeatable liquid doses
- **Maximize Warehouse Storage Space** – increasing product stackability utilizes less square footage
- **Stabilize Organic Products** – extend shelf life without preservatives



# UltraDoser® Technical Specifications



<b>Materials</b>	Stainless Steel Series 300*
<b>Weight</b>	32 lbs (14.5 kg)
<b>Body Dimensions</b>	18"H x 6"W (457.2 x 152 mm)
<b>Dosing Head Dimensions</b>	9.5"H x 2"W (241 x 50.8 mm)
<b>Arm Reach</b>	12" - 18" (304.8 - 457 mm)
<b>Head Pressure</b>	0.45 psi (0.03 bar)
<b>Nozzles</b>	Ships with 0.040", 0.050", 0.060" 0.020" - 0.100" (0.005" increments) available
<b>System Utilities</b>	<b>Liquid Nitrogen:</b> 3 - 22 psi (0.2 - 1.5 bar) <b>Gaseous Nitrogen:</b> 60 - 100 psi (4.1 - 6.9 bar) <b>Electricity:</b> 110 - 240VAC; 50/60Hz, 110W
<b>Steady State Consumption</b>	0.04 gal (0.15 liter) / hour
<b>EP Head Compatible</b>	Yes
<b>Quick Service Feature</b>	No
<b>Vacuum Insulated</b>	Yes
<b>Flexible Arm</b>	No
<b>SoftDose™ Compatible</b>	Yes

\* 304 standard, 316L available upon request

## UltraDoser® Dimensions

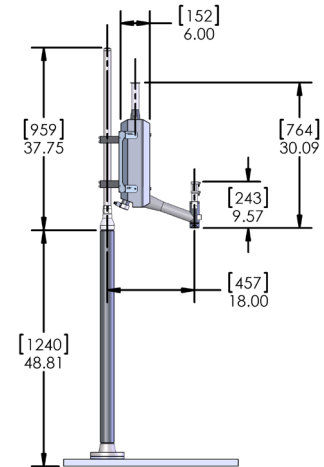

# Controller Technical Specifications

Model	2K	500S	150S
<b>PLC Platform</b>	Allen-Bradley or Siemens	Siemens	Siemens
<b>Display</b>	7" (178 mm) TFT Color LCD Touch Screen	Mono Keypad	Mono Keypad
<b>Dose Duration</b>	5.5 to 1000 ms (0.1 ms intervals)	15 to 1000 ms (1 ms intervals)	20 to 1000 ms (1 ms intervals)
<b>Dose Volume</b>	0.002 to 14 grams/dose	0.02 to 14 grams/dose	0.01 to 14 grams/dose
<b>Encoder Compatible</b>	✓		
<b>Maximum Discrete Dosing (cpm) (cph)</b>	2000* (120,000)	500 (30,000)	150 (9,000)
<b>MicroDose™ Technology</b>	✓		
<b>Line Speed Auto Detect</b>	✓		
<b>Electronic Dose Targeting</b>	✓	✓	
<b>Fixed Delay Mode</b>	✓	✓	✓
<b>Speed Compensated Mode</b>	✓	✓	
<b>Accuracy</b>	± 2% of dose weight	± 5% of dose weight	± 5% of dose weight
<b>Multiple Languages</b>	✓		
<b>RemoteDose™ Capable</b>	✓		
<b>IntelliDose™ Capable</b>	✓		
<b>Recipe Storage</b>	✓		
<b>Certifications</b>	CE, NEMA 4X	CE, NEMA 4X	CE, NEMA 4X

\* Results obtained under specific conditions.

## Your Local Representative



Chart Inc.

46441 Landing Parkway • Fremont, CA 94538

Phone +1 800.371.3303 • Fax +1 408.577.1567 • Service +1 408.371.4932

www.chartdosers.com

© 2015 Chart Inc.

PN 14936230