

BULK CARBON DIOXIDE SUPPLY SYSTEMS

MVE MODELS CARBO-MIZER 450 & 750

Place this chapter in the Beverage section of
the Equipment Manual.

MANUFACTURED
FOR
McDONALD'S™
BY



Chart Industries, Inc.
3505 COUNTY ROAD 42 WEST
BURNSVILLE, MN 55306-3803
TELEPHONE: 952-882-5000
FAX: 952-882-5185



TABLE OF CONTENTS

SAFETY PRECAUTIONS	Page 1
GENERAL DESCRIPTION	Page 2
OPERATION FACTS AND PROCEDURES	Page 5
MCDONALD'S BEVERAGE SYSTEM LAYOUT	Page 6
CARBO-MIZER 450 / 750 VESSEL SPECIFICATIONS	Page 7
VESSEL PARTS IDENTIFICATION & FUNCTION	Page 8
FILL BOX PARTS & HOSE IDENTIFICATION	Page 11
PORTABLE INSTALLATION COMPONENTS	Page 12
TROUBLESHOOTING GUIDE	Page 13
SERVICE AND PARTS	Page 17
WARRANTY	Page 18
VESSEL FLOW SCHEMATIC	Page 19



User Manual

McDONALD'S
Carbo-Mizer 450 • Carbo-Mizer 750

Safety Precautions

IMPORTANT SAFETY PRECAUTIONS

The type of vessel described in this manual holds and dispenses carbon dioxide (CO₂) gas under pressure. All persons using this equipment must read and understand the operation and safety information contained in this manual.

WARNINGS

CO₂ gas is a colorless, odorless, tasteless gas that displaces oxygen and will not support life. The gas is difficult to detect without special equipment. Avoid breathing or contacting CO₂ in gas, liquid or solid form. Exposure to concentrations of less than 5% for less than 15 minutes can cause physical symptoms including unconsciousness, injuries or death. Even low concentrations of CO₂ can cause:

- Dizziness, headaches, nausea or disorientation
- Increased respiration or heart rate
- Shortness of breath or rapid suffocation.

CO₂ is heavier than air and can collect in low areas such as basements, stairwells, and confined spaces. Avoid entry into areas where CO₂ leaks or high concentrations of CO₂ are suspected. Enter those areas with caution only after they have been thoroughly ventilated.

Whenever the vessel is inside a building it's safety relief circuit must be connected to an outdoor vent typically in the fill box. The fill box and/or vent must never be located in or above any below-ground spaces or stairwells. The vessel must not block emergency exits, aisles, fire suppression equipment or utility boxes or accesses. CO₂ lines or hoses must be located away from traffic areas and heat sources and must be protected from potential causes of damage. All connections, lines, and components must be leak-free.

This equipment should be installed and serviced only by professional personnel who are qualified to work with CO₂ and the mini-bulk liquid CO₂

pressure vessels. They should be familiar with all pertinent safety procedures.

FIRST AID AND EMERGENCY ACTION

If inhaled:

- Move to fresh air immediately.
- If not breathing, give artificial respiration.
- If breathing is difficult, give oxygen.
- Get immediate medical attention.

In case of frostbite:

- End exposure immediately.
- Do not rub or pour water on the affected area.
- Get immediate medical attention.

Rescue:

- Do not attempt a rescue in areas of high CO₂ concentrations without proper life-support or rescue equipment. (Avoid being the next victim.)
- Thoroughly ventilate areas of possible high CO₂ concentration before entering them.

In case of spills or leaks:

- Evacuate all personnel immediately from affected areas.
- Thoroughly ventilate the area of the spill or leak before entering.
- CO₂ is heavier than air. It displaces oxygen and will collect in low or confined areas.

FOR MORE INFORMATION CONTACT:

Local CO₂ supplier

or

Compressed Gas Association
725 Jefferson Davis Highway, Suite 1004
Arlington, VA 22202-4100 USA
Telephone: (703) 412-0900
FAX: (703) 412-0900

General Description

System Overview

The Carbo-Mizer carbon dioxide (CO₂) system for McDonald's restaurants is designed for low-pressure storage and supply of carbon dioxide gas for beverage carbonation. The system consists of three primary elements: the CO₂ storage vessel, an outdoor fill box, and fill and vent lines.

Storage Vessel

The vessel is the first of the three primary elements in the Carbo-Mizer storage system. It consists of an inner vessel and an outer vessel, much like a Thermos™ bottle. The space between the two vessels contains a nearly perfect vacuum and a special insulation. The vacuum and insulation minimize the entry of unwanted heat into the liquid CO₂ stored in the inner vessel. When CO₂ gas is needed it is withdrawn from the top (gas space) of the inner vessel and dispensed to the beverage system or other use point.

Vessel Plumbing

Plumbing components on the vessel perform five functions:

- Liquid CO₂ fill
- Gas supply (Gas Delivery)
- Pressure control (Pressure Building)
- Safety (Vent/Relief)
- Pressure and contents measurement (Gauges)

The fill circuit allows liquid CO₂ to be transferred into the vessel during the delivery process. The gas supply circuit dispenses CO₂ gas to the beverage and syrup systems. A pressure control circuit maintains the internal vessel pressure needed to supply CO₂. The vent/relief circuit allows excess pressure to safely exit the vessel and the building. A contents and pressure gauge indicate the status of the CO₂ inside the vessel.

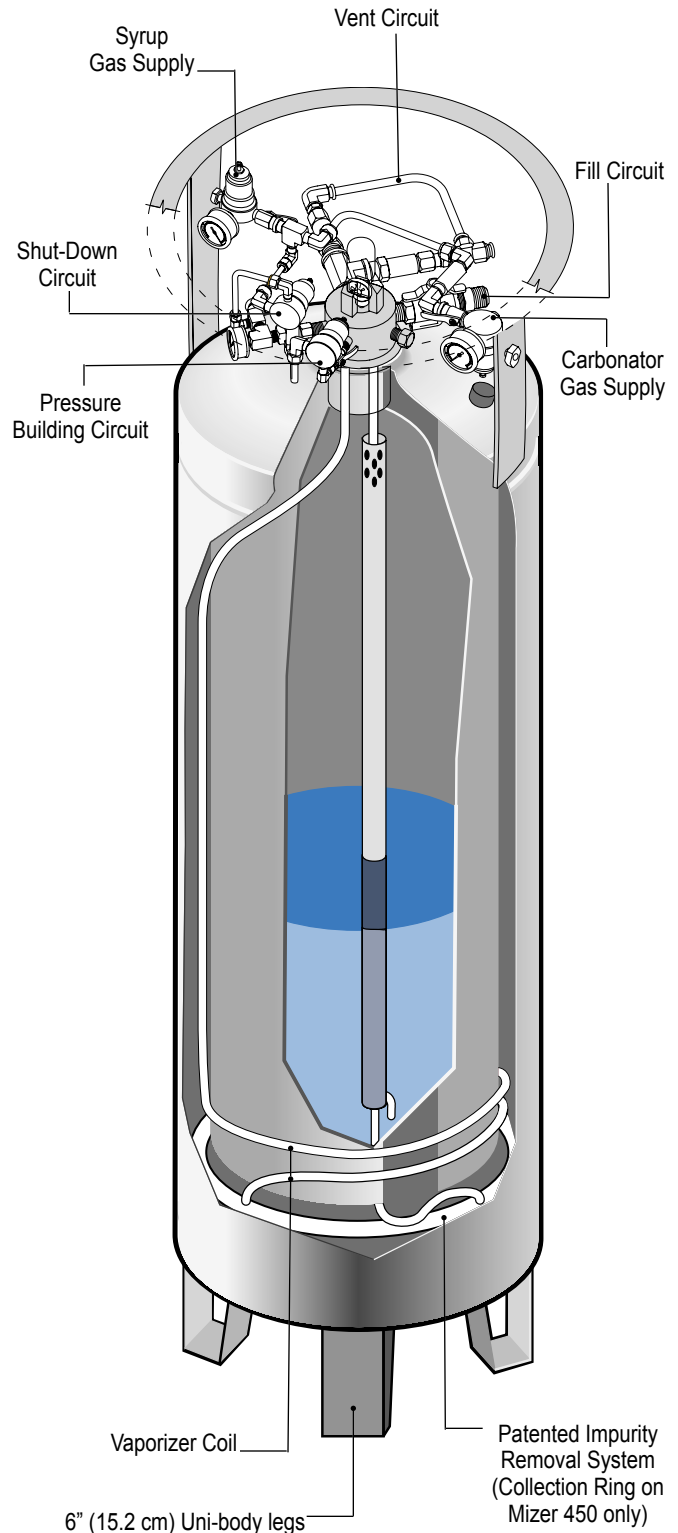

Fill Circuit

The stationary fill circuit consists of a brass fill fitting in the fill box, a fill hose, and a valve on the vessel. Liquid CO₂ is transferred into the vessel through the brass fill box fitting and the fill hose. The shut-off valve on the vessel's fill port allows service to be performed on the fill-box / fill-line segment of the fill circuit without emptying the vessel. A portable vessel's fill circuit consists of a brass fill fitting and bracket secured to the top of the vessel.

Gas Use Circuit

The gas-use circuit supplies gas to the carbonator and syrup systems. CO₂ gas is withdrawn from the gas space above the liquid CO₂ that is stored in the vessel. When demanded at either use point, CO₂ gas passes through the shut-down circuit valve and into the respective final line regulator.

The final line regulators control gas flow to the beverage or syrup systems. The factory setting on the carbonator gas supply regulator is 90 psi but the pressure may be adjusted to suit the needs of the application. This regulator is commonly set between 90 psi and 115 psi for soft drinks. Secondary pressure regulators may be added 'downstream' for applications such as bag-in-the-box or diet systems. The syrup gas use regulator is set at 65 psi for the syrup system. Consult with the use-point equipment manufacturer for the correct regulator and pressure setting.

Pressure Control Circuit

The pressure control circuit, also called the "pressure building" or "PB" circuit, maintains the internal operating pressure of the vessel. Adequate vessel pressure is needed for supplying CO₂ gas and for preventing the stored liquid carbon dioxide from changing to 'dry ice,' the solid form of CO₂.

The pressure building circuit activates to rebuild internal vessel pressure as gas is drawn from the vessel and its pressure drops below a set level. A regulator controls the pressure building process

by sensing the internal vessel pressure. When that pressure drops below the regulator's set point (factory set at 140 psi), the regulator opens allowing liquid CO₂ to flow into the vaporizer where it transforms to gas and re-pressurizes the vessel. When the internal pressure reaches the regulator's set point, the regulator closes and the flow of liquid CO₂ stops.

During the pressure building process cold liquid carbon dioxide flows through a vaporizer coil that is attached to the inside wall of the outer vessel. This cools the outside of the vessel and causes a condensation or frost ring to form near the bottom of the vessel. The appearance of a frost ring is normal when CO₂ is being used. However, if frost is present after some time when no CO₂ gas has been used, such as in the morning before the start of operations, this may indicate a CO₂ leak in a line or the beverage or other use-point system.

Safety Vent Circuit

The inner pressure vessel of this storage system is designed to meet or exceed the ASME Section VIII, Division 1 pressure vessel code. The code dictates that the vessel be protected against excess pressure by a safety relief valve. Chart uses two safety relief valves for added safety. The vessel's safety circuit is comprised of an ASME relief valve set at 300 psig and an additional relief valve set at 450 psig. The relief valves must always be vented outdoors by a vent tube, usually through the fill box, to prevent potential concentration of CO₂ within the building. The 300 psig relief valve may open during CO₂ deliveries or when CO₂ is not being used regularly.

Pressure And Contents Gauges

The vessel pressure gauge measures the pressure in the top (gas space) of the inner vessel. This pressure can normally range between 140 psig and 300 psig but the typical vessel operating pressure is 140 to 165 psig.

The vessel contents gauge measures the approximate level of CO₂ liquid in the vessel. The movement of a magnetic rod "floating" in

the liquid CO₂ causes the needle on the contents gauge to move as the level of liquid CO₂ in the vessel changes.

NOTE: Because the float-rod does not actually float on the surface of the liquid CO₂ it does not provide a precise measurement of liquid CO₂ level.

CO₂ Fill Box

The stainless steel CO₂ fill box is the second major element in a typical bulk CO₂ storage system.

The purpose of the fill box is to provide a convenient point to fill the storage vessel, to make connections for syrup delivery, and to vent excess pressure from the vessel out of the building.

The fill box has a brass fill fitting, a connection for the safety relief vent circuit, a safety snap connection point, and a lockable door. Two standard types of fill boxes are available; a surface-mount model and a flush-mount model.

Fill boxes must be mounted outside the building where they are easily accessible to the CO₂ supplier and where they can safely vent excess CO₂ pressure outdoors. When a vessel is used as a portable system, a vessel-mounted brass fill fitting and an alternative safety relief vent line are used instead of the fill box.

Fill Hose And Vent Line

The third major element of a stationary bulk CO₂ system is comprised of a fill hose and vent line. These lines join the CO₂ storage vessel with the outdoor fill box. The fill hose, constructed with FDA compliant materials, is a pressure rated line that connects the brass fill fitting in the fill box to the fill circuit on the vessel. The vent line is as important as any component in the system. It connects the safety relief valves on the vessel to either the outdoor fill box or to an alternative outdoor vent tube.

NOTE: Whether used as stationary or as portable, the vessel must always be connected to an outdoor vent line when it contains CO₂ and is indoors.

The Bulk CO₂ Supplier

The bulk CO₂ supplier is also an important part of the system. Most CO₂ suppliers not only provide timely delivery of CO₂ but also install and service the system. For service, parts, information, emergency CO₂ delivery, or other CO₂ related assistance, contact the local Chart authorized CO₂ supplier. A place has been designated on page 17 of this manual to record the name and phone number of the CO₂ supplier and other important service contacts.

Operation Facts and Procedures

Operation Facts

1. A vessel's normal internal operating pressure (43) is between 140 psi and 165 psi.
2. Vessel pressure can be as high as 300 psi after a delivery, but returns to its normal operating pressure after a day or two of normal CO₂ use.
3. The carbonator gas supply pressure (45) is normally between 90 psi and 115 psi.
4. The syrup gas supply pressure (44) is normally 65 psi.
5. Frost or condensation on the vessel is normal during periods of CO₂ use.
6. Frost or condensation on the vessel before starting the daily use of CO₂ is a sign of a CO₂ leak. Have the leak fixed.
7. The Mizer 450 holds 453 lb of CO₂ for a use rate of approximately 70 to 100 lb per week. The Mizer 750 holds 771 lb of CO₂ for less frequent fills or a use rate of over 100 lb per week.
8. The contents gauge (22) displays the approximate amount of liquid CO₂ in the vessel.
9. CO₂ becomes dry ice below a pressure of 61 psi. the shutdown circuit will stop CO₂ flow if the vessel pressure (43) reaches 70 psi or less. The push-button reset valve is used to restore pressure in the system after the cause of the low pressure has been corrected.
10. An isolation (shut-off) valve is open when its handle is parallel to the valve body and the line. The valve is closed when its handle is perpendicular to the valve body and the line.
11. See the trouble-shooting section for additional information on potential vessel problems.

General Operating Procedures

1. Every day before starting operations and CO₂ use check for:
 - CO₂ leaks (See “**Safety**”.)
 - Pressure readings (43) & (46) x 2
 - CO₂ contents (22)
 - Abnormal frost or condensation
 - Anything unusual.
2. Always use caution when working with CO₂. Read and understand the “**Safety**” section of this manual.
3. The Carbo system does not require adjustment under normal operating conditions.
4. Check the vessel daily before using CO₂. See ‘operation fact’ number 10.
5. In an emergency the flow of CO₂ from or through the Carbo-Mizer can be stopped by closing the following valves:
 - Valves 33b or 33c to stop the flow of gas to the beverage or syrup system respectively; 33a and 33d to stop gas flow from the vessel.
 - Valve 30 to stop CO₂ flow or leakage through the fill hose and/or the brass fill fitting in the outdoor fill box.
 - Valve 33a to stop CO₂ flow through the pressure-building circuit.
6. For CO₂ equipment issues, call your CO₂ supplier or service specialist. Before calling for service or trouble shooting assistance, please have the following information at hand:
 - Serial number of the vessel
 - Description of the problem
 - Readings from:
 - the vessel contents gauge (22),
 - the vessel pressure gauge (43) and
 - the final line pressure gauges (46).
 - Observations such as unusual frosting and/or events related to the problem.

McDonald's Beverage System Layout

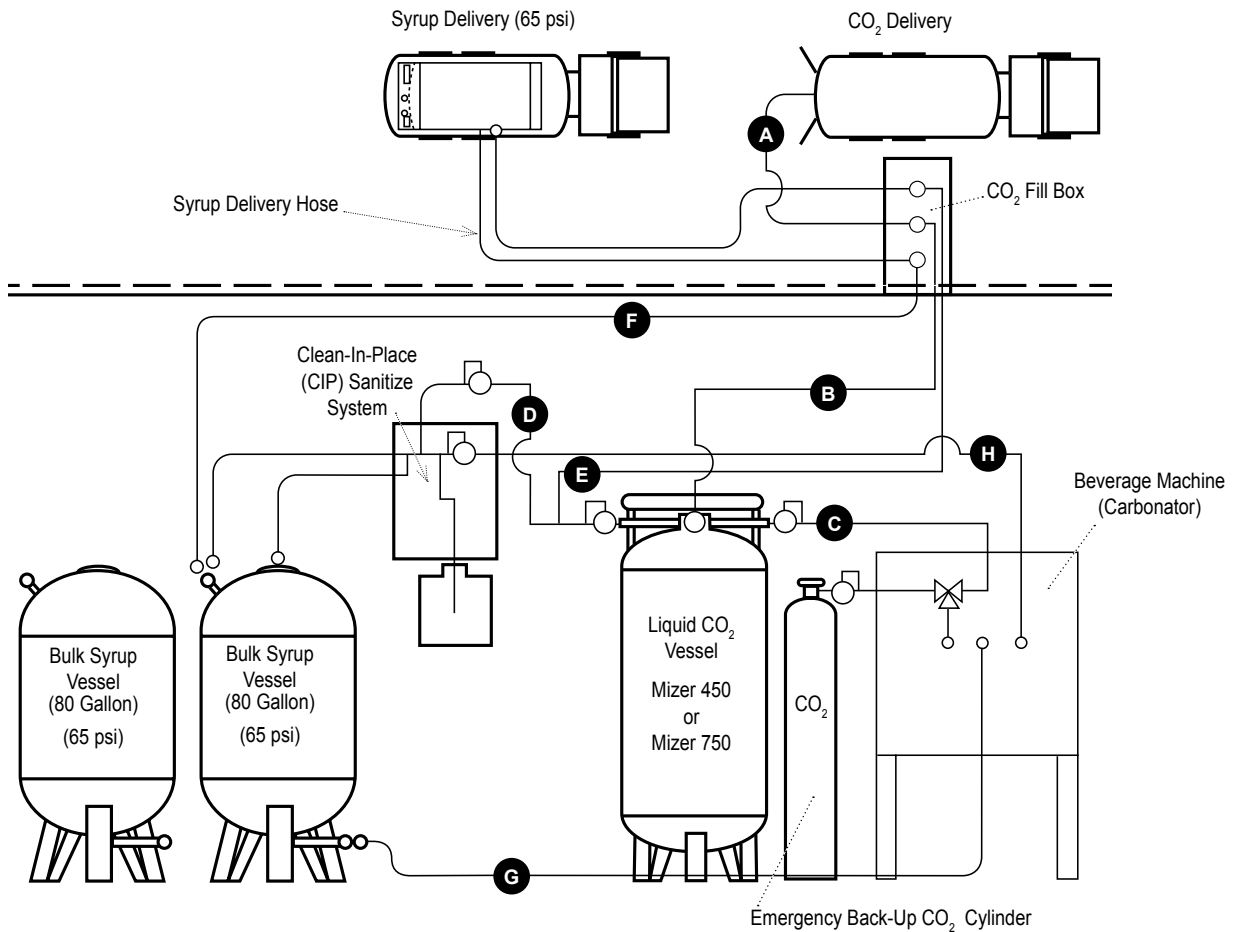

Item	Description	Function
A	CO ₂ delivery truck fill line	Periodic transfer of liquid CO ₂ to on-site Mizer storage vessel
B	In-Store CO ₂ fill line	Transfer of CO ₂ from outside fill-box to Mizer storage vessel
C	CO ₂ gas-use line to beverage machine carbonator	CO ₂ gas supply at 90 -110 psi for beverage carbonation
D	CO ₂ gas-use line to bulk syrup and CIP	CO ₂ gas supply at 65 psi to push syrup to beverage machine
E	CO ₂ gas-use line to fill box 2-pin connection	CO ₂ gas supply at 65 psi to pressurize bulk syrup delivery
F	Syrup delivery line	Bulk syrup delivery line routed through fill box conduit
G	Syrup supply tubing	Transfers syrup from bulk storage vessel to beverage machine
H	Water supply line	Supplies water to beverage machine and sanitation (CIP) system
44	Syrup Side Gas Use Regulator (65 psi)	Controls CO ₂ pressure to bulk syrup
45	Beverage Side Gas Use Regulator (90-125 psi)	Controls CO ₂ gas pressure to carbonator

Carbo-Mizer 450 / 750 Vessel Specifications

	Carbo-Mizer 450	Carbo-Mizer 750
Dimensions		
Diameter	20 in (50.8 cm)	26 in (66 cm)
Height	71.8 in (182.0 cm)	73.5 in (187 cm)
Empty Weight	273 lb (124 kg)	430 lb (195 kg)
Full Weight	726 lb (329 kg)	1201 lb (545 kg)
Net Volume	48 gal (182 liters)	82 gal (310 liters)
CO ₂ Storage Capacity (saturated @125 psig [8.6 bar g])	453 lb (205 kg)	771 lb (350 kg)
Gas Use Connection	1/4" & 3/8" Hose Barb	1/4" & 3/8" Hose Barb
Fill Line Connection	5/8" Male 45° Flare	5/8" Male 45° Flare
Vent Line Connection	1/2" OD Tubing	1/2" OD Tubing
Rates and Pressures		
CO ₂ Delivery Rate Continuous*	5.5 lb/hr (2.5 kg/hr) (489 - 16oz drinks / hr)	10 lb/hr (4.5 kg/hr) (889 - 16oz drinks / hr)
Peak CO ₂ Delivery Rate For One Hour*	10 lb/hr (4.5 kg/hr) (889 - 16 oz drinks)	18 lb/hr (8.2 kg/hr) (1600 - 16 oz drinks)
Evaporation Rate**	2.5 lb/day (1.1 kg/day)	3.0 lb/day (1.4 kg/day)
Max. Allowable Working Pressure (MAWP)	300 psig (20.7 bar g)	300 psig (20.7 bar g)
ASME Relief Setting	300 psig (20.7 bar g)	300 psig (20.7 bar g)
Additional. Relief Setting	450 psig (31.0 bar g)	450 psig (31.0 bar g)
Design Criteria		
	Carbo-Mizer 450 & 750 (unless noted otherwise)	
Design Specifications	ASME Section VIII, Division 1	
Design Specifications	Meets with US and Canadian approvals	
Fill System	Single Line, pressure differential	
Patented Impurity Collection System	Mizer 450 only	
Insulation Type	Vacuum with Super Insulation	
Pressure Control	Pressure Building (PB) Circuit	
Liquid Level Gauge	Float Type: Magnetic 'Roto-Cal'	
Outer Vessel Material	Stainless Steel	
Inner Vessel Material	Stainless Steel	
Floor mount Design (Meets NSF standards)	Six-Inch Permanent Legs	

* Based on 11.25 lb of CO₂ / 1000 16 oz. drinks

** No loss in normal applications

Vessel Parts Identification

McDONALD'S

Carbo-Mizer 450 P/N 11767303

Carbo-Mizer 750 P/N 11770676

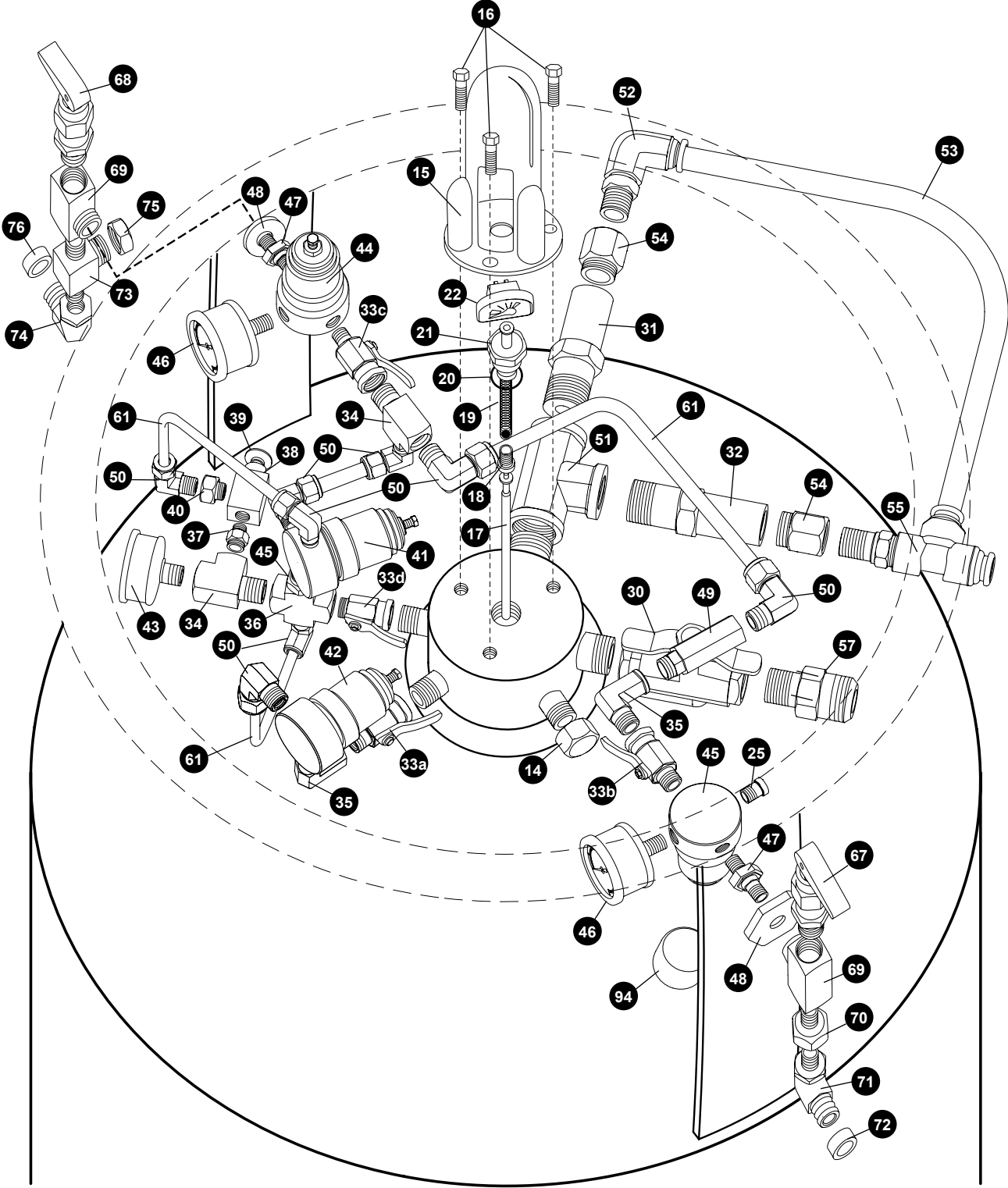

Vessel Parts Identification Continued

ITEM	PART NO.	DESCRIPTION	QTY	FUNCTION
14	1210752	Cap, Brass Hex, (1/4 FPT)	1	Seals unused knuckle port
15	5411486	Sight Gauge Protector, Clear	1	Protects sight gauge
16	2910501	Screws, SS (1/4-20 x 5/8") (not pictured)	3	Attach sight gauge to knuckle
17	9094119	Float Rod Assy. (42 1/2") w/Magnet	1	Indicates liquid CO ₂ level in the vessel
18	5411622	Spring Retainer	1	Secures spring to float rod for adjustment
-	2952321	Set Screw, Spring Retainer (not pictured)	1	Secures Spring to float rod for adjustment
19	5411029	Extension Spring	1	Provides tension on float rod
20	2300244	O-Ring, Liquid Level Gauge	1	Seals brass plug to vessel
21	10591511	Plug, Brass, Liquid Level Gauge	1	Secures the contents gauge to the vessel
-	10643114	Liquid Level Gauge Assembly	1	Includes items 17, 18, 19, and 21
22	10591369	Gauge, Liquid Level / Contents (Roto-Cal)	1	Indicates approximate liquid CO ₂ contents
25	1212962	Brass Plug (1/8" MPT)	1	Seals unused regulator port
30	11082128	Ball Valve (3/8" FPT)	1	Isolates CO ₂ fill hose from vessel.
31	11708451	Relief Valve, 450 psig (1/2" MPT)	1	Secondary inner vessel safety relief valve
32	11708400	Relief Valve, 300 psig (1/2" MPT)	1	Primary inner vessel safety relief valve
33a	1716162	Ball Valve (1/4" MPT x 1/4" FPT)	1	Isolates liquid-side of PB regulator
33b	1716162	Ball Valve (1/4" MPT x 1/4" FPT)	1	On / off control for carbonator gas supply
33c	1716162	Ball Valve (1/4" MPT x 1/4" FPT)	1	On / off control for syrup gas supply
33d	1716162	Ball Valve (1/4" MPT x 1/4" FPT)	1	On / off control for gas side of PB reg. and main gas
34	1211702	Street Tee (1/4" NPT)	2	Connects gas supply circuit components
35	1210462	Street Elbow, Brass 90D (1/4" NPT)	2	Connects isolation valves with gas supply
36	1210762	Cross, Brass, (1/4" FPT)	1	Connects gas supply and shut-down circuit
37	1311742	Nipple, Hex (1/4" NPT x 1/8" NPT)	1	Connects reset valve to gas supply street tee
38	1717889	Reset valve	1	Restores pressure in gas use line
39	1717899	Button, Brass	1	Push button for reset valve
40	1210842	Adapter, Brass (1/4" FPT x 1/8" MPT)	1	Connects reset valve to shut-off circuit
41	11767362	Regulator, Shut-Off. 70 psi, 1/4" NPT	1	Stops gas flow if line pressure drops to 70 psi
42	11767354	Regulator, Pressure Building (PB), 140 psi (1/4" NPT)	1	Controls vessel pressure building (PB) circuit
43	2015179	Pressure Gauge, 0-400 psi (1/4" MPT CBM)	1	Displays internal vessel pressure
44	2111615	Regulator, Syrup Side Gas Use, 65 psi (1/4" NPT)	1	Controls CO ₂ pressure to bulk syrup
45	2111682	Regulator, Final Line, 0-125 psi (1/4" NPT)	1	Controls CO ₂ gas pressure to carbonator
46	11673631	Pressure Gauge, 0-160 psi (1/8" MPT CBM)	2	Indicates CO ₂ gas pressure to use point
47	1310092	Nipple, Hex, Brass, 1/4" NPT	2	Attaches regulator to fitting
48	1013362	Connector, Anchor, Brass 1/4" NPT	2	Gas use line connection
49	1716311	Check Valve, Gas Use	1	Protects vessel components from back flow
50	1013042	Elbow Connector, Brass, 90D (5/16" ODT x 1/4" MPT)	8	Joins SS lines with plumbing components
51	11044869	Branch Tee, (1/2" FPT)	1	Manifolds primary & secondary relief valves
52	11741939	Elbow (1/2" OD x 3/8" MPT)	1	Joins 450 psig relief valve to vent circuit
53	6910623	Tube, Soft Copper Type L (1/2" OD, Nominal .375 in)	ft	Joins vent circuit components
54	1611592	Adapter, Pipe-Away (3/8" FPT)	2	Joins 450 & 350 psig relief valves to vent fittings
55	11741921	Run Tee, (1/2" ODT x 3/8" MPT)	1	Joins 450 & 350 psi relief valves to vent circuit
57	1110112	Connector (5/8" ODT x 3/8" MPT 45° Flare)	1	Connects CO ₂ fill hose to vessel
61	2710071	Tubing, Stainless (5/16" OD)	ft	Gas use, pressure build, and shut-off plumbing line

Vessel Parts Identification Continued

ITEM	PART NO.	DESCRIPTION	QTY	FUNCTION
-	9722439	Installation Kit, McDonald's CO ₂	-	Includes connectors and tubing for CO ₂ installation
67	1812352	Relief Valve, 130 psi (1/4")	1	Prevents beverage system over-pressurization (Included in installation kit P/N 9722439)
68	1812342	Relief Valve, 75 psi (1/4")	1	Prevents bulk syrup vessel over-pressurization (Included in installation kit P/N 9722439)
69	1213092	Tee, Brass (1/4" F x 1/4" F x 1/4" MPT)	2	Connects gas use line to vessel (Included in installation kit P/N 9722439)
70	1111502	Union, brass (1/4" MPT x 1/4" Flare)	1	Connects carbonator gas-use line components (Included in installation kit P/N 9722439)
71	1611821	Elbow, SS (1/4" FL x 3/8" Hose)	1	Connects with carbonator gas-use line (Included in installation kit P/N 9722439)
72	3411331	Clamp, Stepless Ear For 3/8" ID Tubing	5	(Included in installation kit P/N 9722439)
73	1111512	Tee, Run, Brass (1/4" MPT)	1	Connection port for syrup delivery gas (Included in installation kit P/N 9722439)
74	1611461	Elbow, SS (1/4" Hose x 1/4 ODT)	1	Connects with syrup gas-use line (Included in installation kit P/N 9722439)
75	1111292	Cap Nut (1/4" ODT 45D Flare)	1	Protects flare fitting (Included in installation kit P/N 9722439)
76	3411511	Clamp, Stepless Ear For 1/4" ID Tubing	6	Syrup gas-use connections (Included in installation kit P/N 9722439)
-	6511706	Quick Connect, Two Slot (1/4" Tube) (not pictured)	1	CO ₂ line connector to bulk syrup vessel (Included in installation kit P/N 9722439)
-	2811606	Tubing, 1/4" ID Red Line, 20 ft. (not pictured)	1	Syrup gas-use line (Included in installation kit P/N 9722439)
-	3411312	Clamp, Stepless Ear For 1/4" ID (not pictured)	4	(Included in installation kit P/N 9722439)
-	2811586	Tubing, 3/8" ID Red Line, 100 ft. (not pictured)	1	Carbonator gas line (Included in installation kit P/N 9722439)
-	2811616	Tubing, 1/4" ID Green Line, 5 ft. (not pictured)	1	(Included in installation kit P/N 9722439)
94	3911217	Cap, Black	1	Covers vacuum pump-out port
-	11541259	Label, McDonald's	1	Denotes McDonald's approved equipment
-	3836609	Label, Operations	1	Describes vessel safety and operations
-	10807553	Label, CO ₂ Vessel	1	Denotes CO ₂ vessel (UN 2187)
-	11197611	Label Kit, NYCFD Approval, (Stationary Installation)	1	Operation, caution, approval, and manufacturer
-	11197646	Label Kit, NYCFD Approval, (Portable Installation)	1	Operation, caution, approval, and manufacturer
-	11784496	Label Only, Caution Carbon Dioxide	1	Included in label kits
-	3832679	Decal Only, CO ₂ NYCFD COA #4912 (Stationary)	1	Included in label kit 11197611
-	10915896	Decal Only, CO ₂ NYCFD COA #4748 (Portable)	1	Included in label kit 11197646

Fill Box Parts & Hose Identification

Surface Mount Fill Box (P/N 9722329)

Flush Mount Fill Box Shell (Without Panel) (P/N 8512629)

Flush Mount Fill Panel (With Fittings) (P/N 9722859)

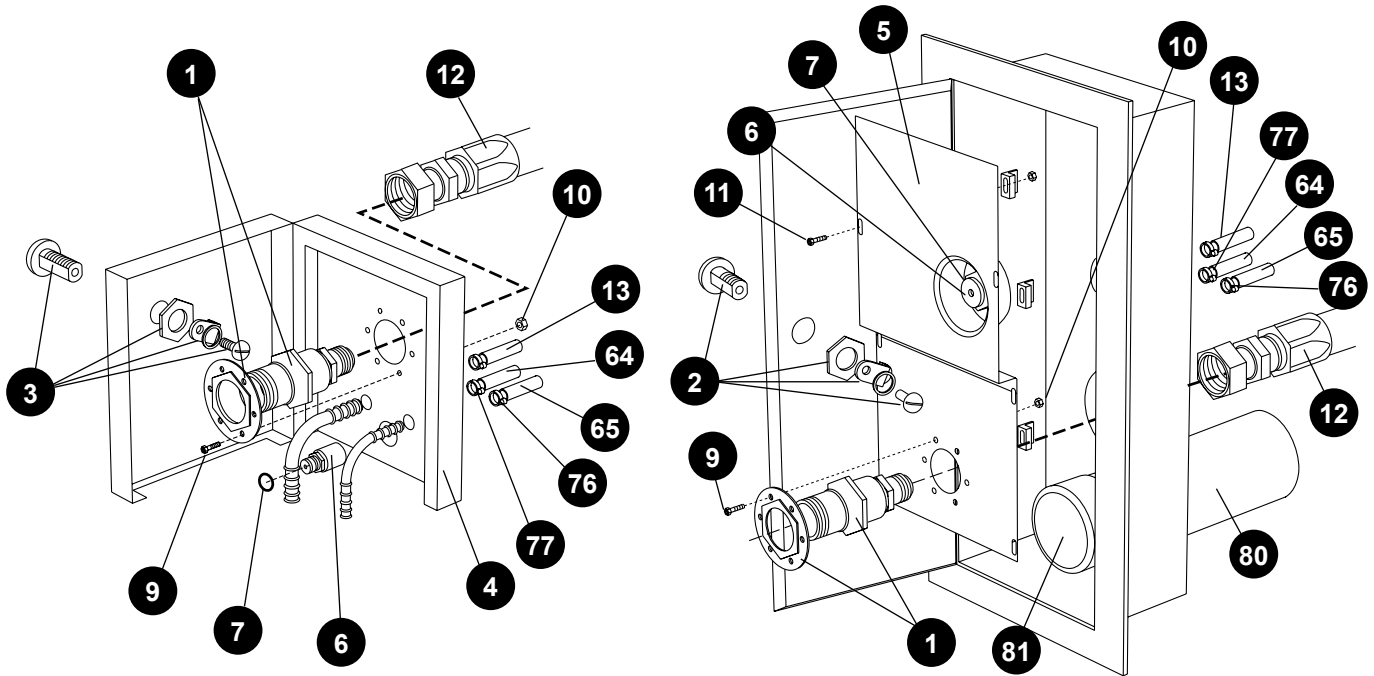

ITEM	PART NO.	DESCRIPTION	QTY.	FUNCTION
1	11014459	CO ₂ Fill Fitting, Brass (includes retainer ring)	1	Connection for CO ₂ delivery vessel hose
2	4310689	Lock Assembly (includes key) for Flush Mount Box	1	Locks fill box door
-	4310959	Key for Lock Assembly (not pictured)	-	Replacement key for fill box
3	4311129	Lock and Key Assembly for Surface Mount Box	1	Locks fill box door
4	8505789	Surface-Mount CO ₂ Fill Box (without fittings)	1	Allows outdoor filling and venting of vessel
5	8517839	Flush-Mount Fill Box Panel (without fittings)	1	Holds brass fill fitting and 2-pin connector
6	6511631	Quick Connect, 2-Pin	1	CO ₂ connection for syrup delivery
-	12881917	O-Ring		
7	4710619	Outside O-Ring (5/16" x 1/2")	1	Seals 2-pin connection for syrup delivery gas
9	2913591	Machine Screw, SS (#10-32 x 1/2")	6	Secures fill fitting retainer to fill box
10	2915131	Locknut, SS (10 x 32) with nylon insert	6	Secures fill fitting retainer to fill box
11	2913981	Screws, SS (#8 x 1/2")	6	Secures fill panel to fill box
-	10973324	CO ₂ Fill and Vent Hose Kit (15 ft. each line)	1	(Included in installation kit P/N 9722439)
12	10802947	CO ₂ Fill Hose Only, 15 ft. (2000 psi & FDA)	1	Transfers liquid CO ₂ from fill box into vessel
13	2811726	Vent Hose Only, 15 ft	1	Vents excess vessel pressure outdoors
64	2811606	Tubing, red line (1/4" ID)	20 ft	(Included in installation kit P/N 9722439)
65	2811616	Tubing, green line (1/4" ID)	5 ft	(Included in installation kit P/N 9722439)
76	3411511	Clamp, Stepless (for 1/4" ID green line tube)	6	(Included in installation kit P/N 9722439)
77	3411321	Clamp, Stepless (for 1/4" ID red line tube)	4	(Included in installation kit P/N 9722439)
80	8503796	Conduit, Syrup Pass-Thru	1	(Included in installation kit P/N 9722439)
81	10772160	Pipe Cap 2-1/2" PVC	1	Syrup pass-thru cover (Included with fill-box shell P/N 8512629)

Portable Installation Components

Syrup Gas Use

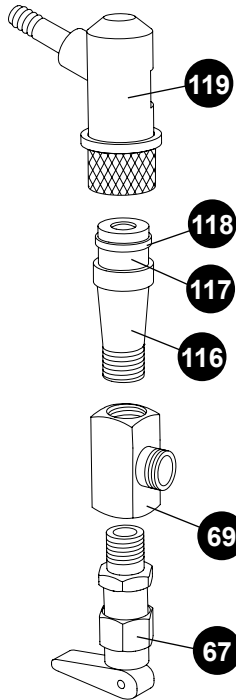

Carbonator Gas Use

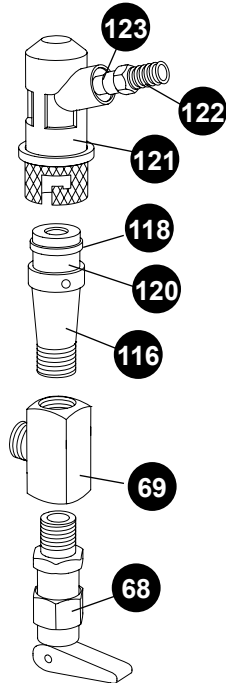

Vent Line (See page 8)

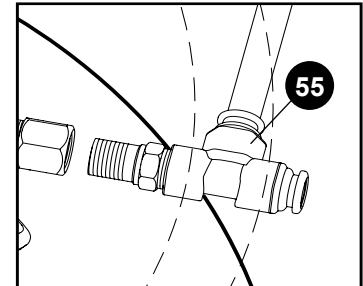

Fill Fitting

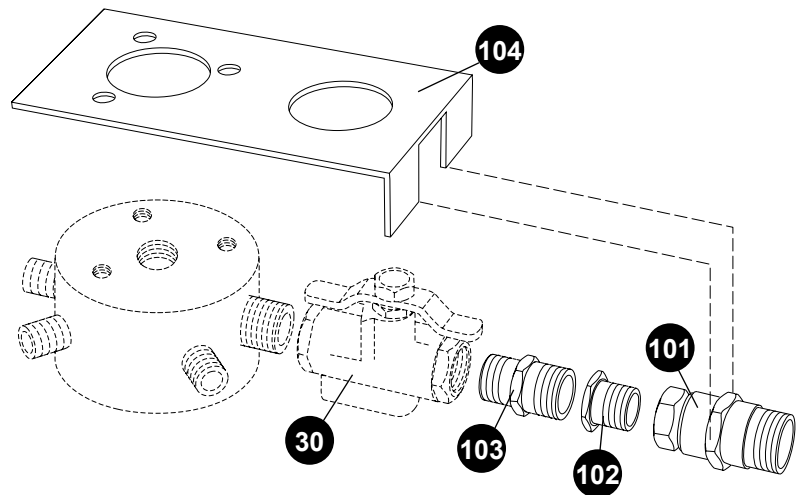

ITEM	PART NO.	DESCRIPTION	QTY	FUNCTION
30	11082128	Ball Valve (3/8" FPT) (equipped on vessel)	1	Isolates CO ₂ fill hose from vessel.
67	1812352	Relief Valve, 130 psi (1/4")	1	Protects the beverage system from over-pressurization
68	1812342	Relief Valve, 75 psi (1/4")	1	Protects bulk syrup vessels from over-pressurization
69	1213092	Branch Tee, Brass (1/4"F x 1/4"F x 1/4" MPT)	2	Joins quick-connect and relief valve to gas-use port
101	10662041	CO ₂ Fill Fitting, Brass (3/4" thresd)	1	Connects CO ₂ transfer hose to vessel CO ₂ fill line
102	1212062	Hex Bushing (3/8" FPT x 3/4" MPT)	1	Joins fill fitting to vessel
103	1310072	Hex Nipple, (3/8" NPT x 1-1/4" long)	1	Joins fill fitting to vessel
104	10933218	CO ₂ Fill Fitting Support Bracket	1	Secures CO ₂ fill fitting to vessel
116	9722509	Tank Boss Adapter (1/4" MPT)	2	Connects pin connector to vessel gas line
117	6511631	Quick Cinnect, Two-Pin Lock	1	Connects and releases syrup gas-use line
118	4710619	O-Ring (1/2" OD)	2	Seals pin connector when joined
119	6511706	Quick Connect, Two-Slot	1	Connects and releases syrup gas-use line
120	1611861	Quick Connect, Three-Pin Lock	1	Connects and releases carbonator gas-use line
121	10806690	Quick Connect, Three-Slot	1	Connects and releases carbonator gas-use line
122	10727959	Adapter Flare to Barb (1/4" F)	1	Barb connector for carbonator gas-use line
123	10806711	Washer, 1/4" Flare	1	Seals connection of barb and three-slot connectors

Troubleshooting Guide

CO₂ Storage Vessel

INDICATION	POSSIBLE CAUSE	CORRECTIVE ACTION
No CO ₂ to carbonator or syrup systems. OR Carbonated drinks are flat.	CO ₂ storage vessel is empty.	<ol style="list-style-type: none"> 1. Switch to emergency CO₂ gas cylinder. 2. Call CO₂ supplier for delivery.
	Isolation valves (33a, b, c, d) closed.	Open valve or valves as needed.
	Vessel pressure (43) is low (110 psi or less).	<ol style="list-style-type: none"> 1. Switch to emergency CO₂ gas cylinder. 2. Stop CO₂ withdrawal from bulk CO₂ vessel by closing isolation valves 33b and 33c. 3. If vessel pressure fails to rebuild see section on low vessel pressure.
	Pressure building regulator (42) not operating properly	<ol style="list-style-type: none"> 1. Ensure that isolation valves (33a & 33d) are open. 2. Valve handles should be parallel with the line. 3. Regulator is set too low, plugged, or faulty. Call CO₂ service agent.
	Unknown	Call CO ₂ service agent.
Frost on the bottom or sides of the vessel.	A normal condition during or following CO ₂ use.	None
	Leak in beverage system and/or gas supply lines or CO ₂ fill box. (When frost is present after extended periods of no CO ₂ use.)	<ol style="list-style-type: none"> 1. See "Safety". Evacuate & ventilate. Check for frost in the morning before CO₂ has been used. If possible, locate and correct leak. 2. Call appropriate equipment service agent.
Frost on the top of the vessel.	Normal condition during periods of CO ₂ use.	None
	CO ₂ leak from the beverage or syrup system (rupture disc), plumbing, or CO ₂ fill box. (Frost present after extended periods with no intentional CO ₂ use.)	<ol style="list-style-type: none"> 1. See "Safety". Evacuate & ventilate the room. 2. Check for frost in the morning before CO₂ use. Other indicators include high CO₂ usage, frost on sides of the vessel, low vessel pressure, etc. Locate & correct leak if possible. 3. Call appropriate service agent.
Constant low vessel pressure. (gauge 43 below 110 psi)	PB regulator (42) set low or plugged.	Call CO ₂ service agent for service.
	PB shut-off valves (33a & 33d) closed.	Open valve by turning handle parallel to line.
	CO ₂ leak from vessel plumbing, CO ₂ fill box and/or vessel safety system	<ol style="list-style-type: none"> 1. See "Safety". Evacuate & ventilate the room. 2. Call CO₂ service agent.

Troubleshooting Guide Continued

CO₂ Storage Vessel

INDICATION	POSSIBLE CAUSE	CORRECTIVE ACTION
Constant high vessel pressure. (43 over 200 psi)	Normal condition for a few days following a CO ₂ delivery.	None
	Normal when little or no CO ₂ is used.	None
	PB regulator (42) set too high.	Call CO ₂ service agent.
	Vessel has a weak vacuum.	Call CO ₂ service agent.
High CO ₂ consumption.	Increased beverage sales or CO ₂ use.	None
	Vessel pressure (43) constantly high.	See section on vessel pressure too high.
	CO ₂ leak from vessel plumbing, CO ₂ fill box, gas lines, and/or beverage or syrup use-point equipment.	<ol style="list-style-type: none"> 1. See “Safety”. Evacuate & ventilate room. 2. Locate & correct leak if possible 3. Call appropriate service agent.
	Error in CO ₂ supplier invoice.	Check CO ₂ usage history / pattern against supplier invoices. Consult CO ₂ supplier.
CO ₂ vessel will not fill.	CO ₂ vessel is already full.	None
	Fill valve (30) is shut off or is faulty.	Consult CO ₂ service agent.
	Brass fill fitting in CO ₂ fill box and/or on truck’s delivery hose is faulty.	<ol style="list-style-type: none"> 1. Consult with CO₂ supplier or service agent. 2. Have brass fill fitting(s) replaced if needed.
	Differential between store vessel pressure and delivery pressure is too small.	<ol style="list-style-type: none"> 1. Verify delivery vessel pressure is at least 50 psi higher than the store vessel pressure (43). 2. Vent store vessel to lower pressure if needed. 3. Never vent store vessel pressure to lower than 125 psi.
	Delivery vessel is empty.	Consult supplier. Arrange for another delivery.
	Delivery vessel empty or truck delivery hose is obstructed, e.g. vehicle stopped on hose or hose is bent.	Ask driver to make another delivery or clear obstruction or wait until obstruction clears.

CO₂ Storage Vessel

INDICATION	POSSIBLE CAUSE	CORRECTIVE ACTION
Hissing sounds or evidence of gas leak.	Normal for short periods of time from some regulators and relief valves.	Observe leak, if it is not large <u>and</u> does not last long <u>and</u> occur frequently, no action is needed.
	Large leaks from elsewhere in the system, sustained leaks, or frequent leaks are not normal.	<ol style="list-style-type: none"> 1. See “Safety”. 2. Evacuate all personnel from affected areas. 3. Ventilate the area. 4. Call CO₂ service agent.
Final line / gas use pressure gauges (46) indicate less than 65 psi on the syrup side and/or less than 100 psi on the carbonator side.	Final line regulators (44) or (45) intentionally set lower by beverage service agent.	None
	Final line regulators (44) or (45) not operating in proper pressure range.	Call CO ₂ service agent.
	Final line pressure gauge (46) damaged or faulty.	Call CO ₂ service agent.
	One or more of the causes listed in “no CO ₂ ” or “flat drinks” problem section.	<ol style="list-style-type: none"> 1. See indication sections regarding “no CO₂”, “flat drinks” etc. 2. Call CO₂ service agent.

Troubleshooting Guide Continued

Fill Box

INDICATION	POSSIBLE CAUSE	CORRECTIVE ACTION
Fill box door will not close, lock, or open.	Wrong key.	<ol style="list-style-type: none"> 1. Verify correct key and retry. 2. Contact CO₂ supplier for spare key. 3. Order new key.
	Lock dirty or damaged.	<ol style="list-style-type: none"> 1. Clean and oil lock 2. Replace lock if necessary
Brass fill fitting in fill box leaking or hissing.	Particle of ice or debris caught in fill fitting poppet.	<ol style="list-style-type: none"> 1. If driver is still on site, reconnect CO₂ delivery hose and then disconnect. 2. If driver is not available, carefully press poppet with dull instrument to re seat poppet. 3. If leak continues after line warms, close the fill isolation valve (30) and call service agent.
	Fitting is defective or sealing surface is worn due to normal wear.	Close the fill isolation valve (30) on the vessel and call service agent to replace fitting.
Threads on brass fill fitting are worn or stripped.	Normal wear. Fill fitting must be replaced.	Contact CO ₂ service agent to replace fitting.
	Fill fitting cross threaded with the CO ₂ delivery hose coupler	Contact CO ₂ service agent to replace fitting.
CO ₂ is venting from fill box.	Normal during CO ₂ delivery.	None
	Normal for short periods of time if vessel pressure is at or over 300 psi	<ol style="list-style-type: none"> 1. NONE if for short period(s) of time 2. If vessel pressure consistently over 300 psi, see section on vessel pressure too high.
	Fill fitting is not sealing properly.	Call CO ₂ service agent to replace fitting.

Service and Parts

Service and Maintenance

1. Service or maintenance work on the Carbo-Mizer CO₂ storage system should be performed only by Chart trained and authorized professional service agents who are familiar with CO₂, bulk liquid CO₂ pressure vessels, and all pertinent safety and service procedures. Chart recommends the use of Chart approved replacement parts. Contact Chart for the name of the authorized service agent(s) in your area.
2. Before calling for service or troubleshooting assistance, please have the following information at hand:
 - Serial number of the vessel
 - Description of the problem
 - Readings from:
 - the contents gauge (22),
 - the vessel pressure gauge (43),
 - the final line pressure gauges (46).
 - Any special observations (for example: unusual frosting or events related to the problem)
3. Chart recommends that a qualified professional service agent perform a

thorough preventative maintenance check on the system at least once every two years. The check should be done to ensure safety and optimal system performance.

4. The Carbo- Mizer bulk CO₂ storage system has no user serviceable parts. An authorized professional service agent should perform all service work.

NOTE: Any attempt by an unauthorized person to service or perform unauthorized modifications on the equipment will void the warranty.

Ordering Parts Or Service

For service contact your local authorized MVE Beverage Systems CO₂ supplier or equipment service agent. For parts contact your local authorized Chart service agent or order on-line directly from Chart at www.chartparts.com. Know the model and serial number of the vessel for which you are ordering parts. To assure that your order is processed promptly, list each item separately, being careful to specify the quantity, the part number, and the description of each item being ordered.

Important Telephone Numbers

Company	Contact Person	Phone Number
CO ₂ Supplier	_____	_____
	<u>After-Hours / Emergency Number</u>	_____
CO ₂ Service Agent	_____	_____
CO ₂ Equipment Installer	_____	_____
MVE Beverage Systems Customer Service	(952) 882-5000 or	(800) 247-4446 {toll free in US}
MVE Beverage Systems Technical Service	(952) 882-5000 or	(800) 253-1769 {toll free in US}

Warranty

WARRANTY POLICY

Chart Industries, Inc. warrants to McDonald's Restaurants (the purchaser) the McDonald's Miser bulk CO₂ system equipment for one (1) year from the Chart invoice date, that said equipment shall be free from any defects in workmanship and materials. Chart also warrants the reliability of the vacuum in the CO₂ storage vessel for 5 (five) years from the date of the original Chart invoice.

Purchaser agrees that as a pre-condition to any Chart liability hereunder, Purchaser or its appointed agents shall fully inspect all goods immediately upon delivery and shall give Chart written notice of any claim or purported defect within ten (10) days after discovery of such defect.

As a further pre-condition to any Chart liability hereunder, an approved Chart service company must supply both parts replacement and labor. Chart may elect to repair or replace such equipment or any defective component or part thereof which proves to be defective, or to refund the purchase price paid by the original Purchaser. Chart shall not be liable for defects caused by the effects of normal wear and tear, erosion, corrosion, fire, explosion, misuse, or unauthorized modification.

Alterations or repair by others than those designated and approved by Chart or operation of such equipment in a manner inconsistent with Chart accepted practices and all operating instructions, unless pre-authorized in writing by Chart, shall void this Warranty.

Chart's sole and exclusive liability under this Warranty is to the Purchaser and shall not exceed the lesser of the cost of repair, cost of replacement, or refund of the net purchase price paid by the original Purchaser.

Chart is not liable for any losses (including CO₂), damages, or costs of delays, including incidental or consequential damages. Chart specifically makes no warranties or guarantees, expressed or implied, including the warranties of merchantability or fitness for a particular purpose or use, other than those warranties expressed herein.

WARRANTY CLAIMS PROCEDURE

1. All warranty claims must be previously authorized by: Chart Ind., Inc. Telephonic / electronic approval may be obtained by contacting Chart's MVE Beverage Systems Technical / Customer Services at:

- Telephone: 952-882-5000
800-253-1769
(Toll free in U.S.)
- Facsimile: 952-882-5185

or by writing to:

Chart Industries, Inc.
MVE Beverage System Technical Service
3505 County Road 42 West
Burnsville, MN 55306-3803
USA

2. Authorization must be obtained from Chart prior to shipping any equipment to Chart facilities. In order to process the return of a vessel its model and serial number must be provided. If approved, a Return Material Authorization (RMA) number will be provided. The RMA number must be prominently indicated on the packing slip and any packaging that accompanies the goods being returned. The customer returning the goods is responsible for all freight, proper packing, and any damage incurred during shipment of the goods back to Chart.

System Flow Schematic

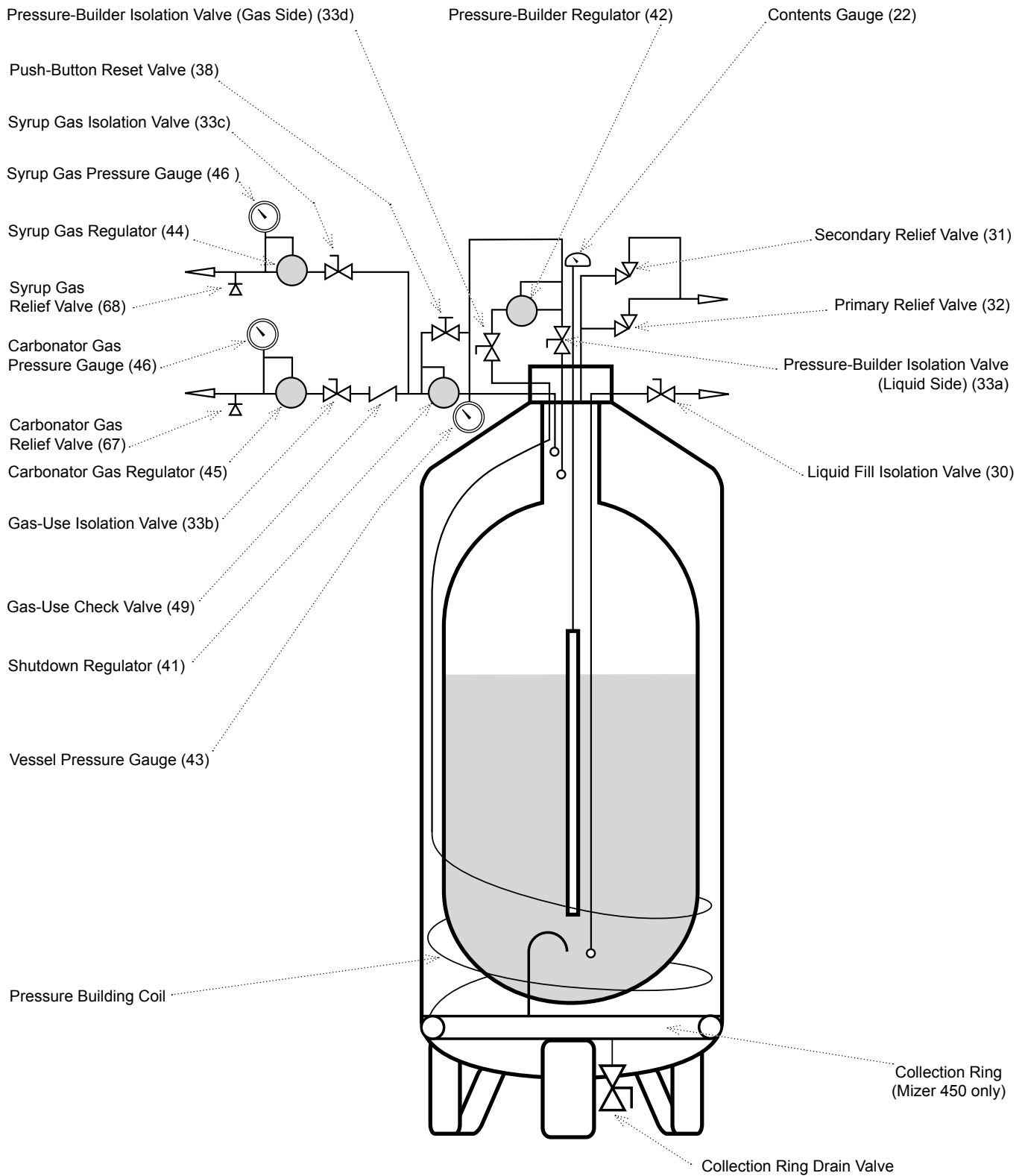

McDonald's Mizer 450 & 750 CO₂ System

chartparts.com

- Order parts directly from Chart through a personalized account at www.chartparts.com.
- Simply establish an account password and "log-in."
- Service is available 24 hours a day and provides same-day shipping on all stock parts.
- Chartparts provides access to shipment tracking, transaction history, and personalized account information for convenient account management.

Chart Industries, Inc.
3505 County Road 42 West
Burnsville, MN 55306-3803



chartbeverage.com

Copyright © 2003 Chart Industries
PART NUMBER 11817059 5/03

U.S. 800-247-4446 • Worldwide 952-882-5000 • Fax 952-882-5185 • www.chart-ind.com • e-mail: beverage@chart-ind.com