



MVE® Carbo Series

User Manual



www.chartbeverage.com



User Manual

Carbo-MIZER 400 • Carbo-MIZER 450 • Carbo-MIZER 500

Carbo-CHARGER • Carbo-MITE

Table of Contents

I	Safety	1
	Warnings	
	First Aid And Emergency Action	
	Further Information Sources	
II	General Description	2
	System Overview	
	Stationary Versus Portable Fill Installations	
	Storage vessel	
	Vessel Plumbing	
	Fill Circuit	
	Gas Use Circuit	
	Pressure Control Circuit	
	Safety Vent Circuit	
	Pressure And Contents Gauges	
	CO ₂ Fill Box	
	Fill Hose And Vent Line	
	The Bulk CO ₂ Supplier	
III	Vessel Specifications	6
	Dimensions	
	Rates and Pressures	
	Design Criteria	
IV	Parts Identification	7
	Basic and Sure-Fill™ Equipped Storage Vessel Parts Diagrams	
	Carbo Series Storage Vessel Componentes	
	Stationary Installation Components	
	Portable Installation Components	
V	Operation And Troubleshooting	12
	Facts To Know	
	General Operating Instructions	
	Troubleshooting Guide - CO ₂ Storage Vessel	
	Troubleshooting Guide - Fill Box	
VI	Ordering Service And Parts	17
	Service And Maintenance	
	Ordering Parts Or Service	
	Important Telephone Numbers	
VII	Warranty	18
	Warranty Policy	
	Warranty Claims Procedure	
VIII	System Flow Schematic	19

I Safety

IMPORTANT SAFETY PRECAUTIONS

The type of vessel described in this manual holds and dispenses carbon dioxide (CO₂) gas under pressure. All persons using this equipment must read and understand the operation and safety information contained in this manual.

WARNINGS

CO₂ gas is a colorless, odorless, tasteless gas that displaces oxygen and will not support life. The gas is difficult to detect without special equipment.

Avoid breathing or contacting CO₂ in gas, liquid or solid form. Exposure to concentrations of less than 5% for less than 15 minutes can cause physical symptoms including unconsciousness, injuries or death. Even low concentrations of CO₂ can cause:

- Dizziness, headaches, nausea or disorientation
- Increased respiration or heart rate
- Shortness of breath or rapid suffocation.

CO₂ is heavier than air and can collect in low areas such as basements, stairwells, and confined spaces. Avoid entry into areas where CO₂ leaks or high concentrations of CO₂ are suspected. Enter those areas with caution only after they have been thoroughly ventilated.

Whenever the vessel is inside a building it's safety relief circuit must be connected to an outdoor vent typically in the fill box. The fill box and/or vent must never be located in or above any below-ground spaces or stairwells. The vessel must not block emergency exits, aisles, fire suppression equipment or utility boxes or accesses. CO₂ lines or hoses must be located away from traffic areas and heat sources and must be protected from potential causes of damage. All connections, lines, and components must be leak-free .

This equipment should be installed and serviced only by professional personnel who are qualified

to work with CO₂ and the mini-bulk liquid CO₂ pressure vessels. They should be familiar with all pertinent safety procedures.

FIRST AID AND EMERGENCY ACTION

If inhaled:

- Move to fresh air immediately.
- If not breathing, give artificial respiration.
- If breathing is difficult, give oxygen.
- Get immediate medical attention.

In case of frostbite:

- End exposure immediately.
- Do not rub or pour water on the affected area.
- Get immediate medical attention.

Rescue:

- Do not attempt a rescue in areas of high CO₂ concentrations without proper life-support or rescue equipment. (Avoid being the next victim.)
- Thoroughly ventilate areas of possible high CO₂ concentration before entering them.

In case of spills or leaks:

- Evacuate all personnel immediately from affected areas.
- Thoroughly ventilate the area of the spill or leak before entering.
- CO₂ is heavier than air. It displaces oxygen and will collect in low or confined areas.

FOR MORE INFORMATION CONTACT:

Local CO₂ supplier

or

Compressed Gas Association
725 Jefferson Davis Highway, Suite 1004
Arlington, VA 22202-4100 USA
Telephone: (703) 412-0900
FAX: (703) 412-0900

II General Description

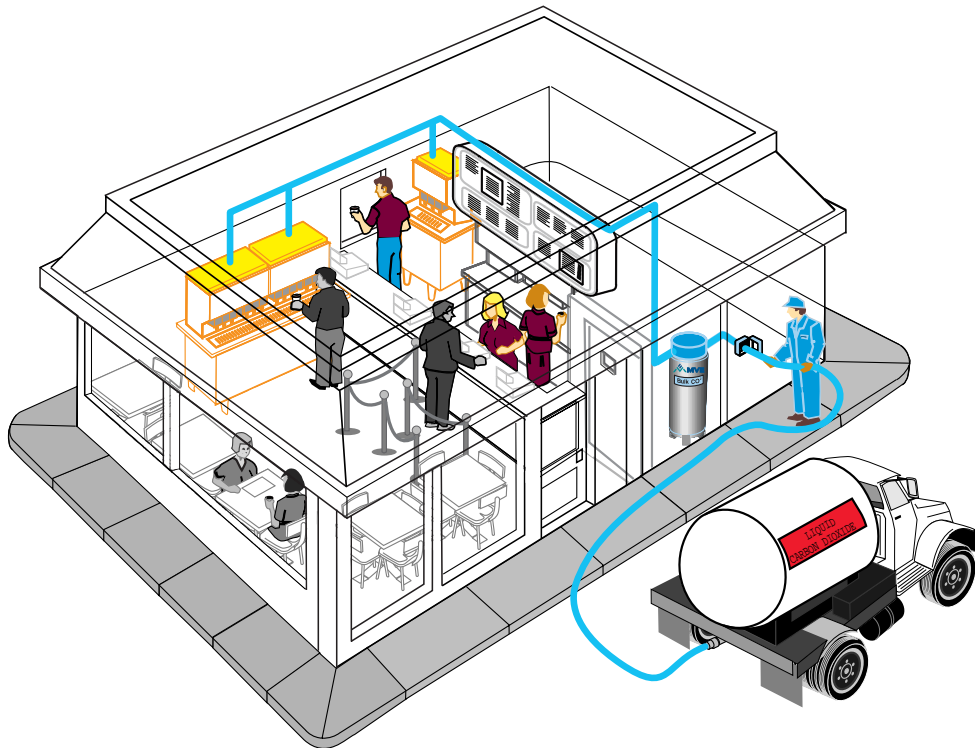

System Overview

The MVE Carbo-Mite, Carbo-Charger and Carbo-Mizer bulk carbon dioxide (CO₂) systems are designed for low pressure liquid storage and supply of carbon dioxide gas for beverage carbonation, brewing, beer dispensing, and other purposes. The system consists of three primary elements: the CO₂ storage vessel, CO₂ fill box, and the fill and vent hoses.

Stationary Versus Portable Installations

The bulk CO₂ system can be operated either as a stationary or as an on-site portable system for fill purposes. The most common system employs a permanently installed vessel, an outdoor-mounted CO₂ fill box, and the connecting fill and vent hoses. The fill hose and vent line join the vessel to the outdoor fill box. The fill box allows the CO₂ supplier to fill the vessel from outside the building. The delivery process takes only about 5-10 minutes and does not interrupt the CO₂ user's operations.

If a fill box cannot be installed on the outside of the building or the distance between the fill box and the vessel is too long, then a portable vessel system configuration might be an alternative. The system can be converted to on-site portability for fill purposes with an optional three-wheeled cart and special plumbing components including quick disconnect couplings and a vessel-mounted fill fitting. This allows the vessel to be temporarily disconnected from the gas supply and vent circuits and moved outdoors for refilling. Before electing to use a portable system, consult with your Chart representative for operational considerations.

Note: The Carbo series bulk CO₂ storage vessels are not DOT regulated and must not be transported when they contain liquid CO₂.

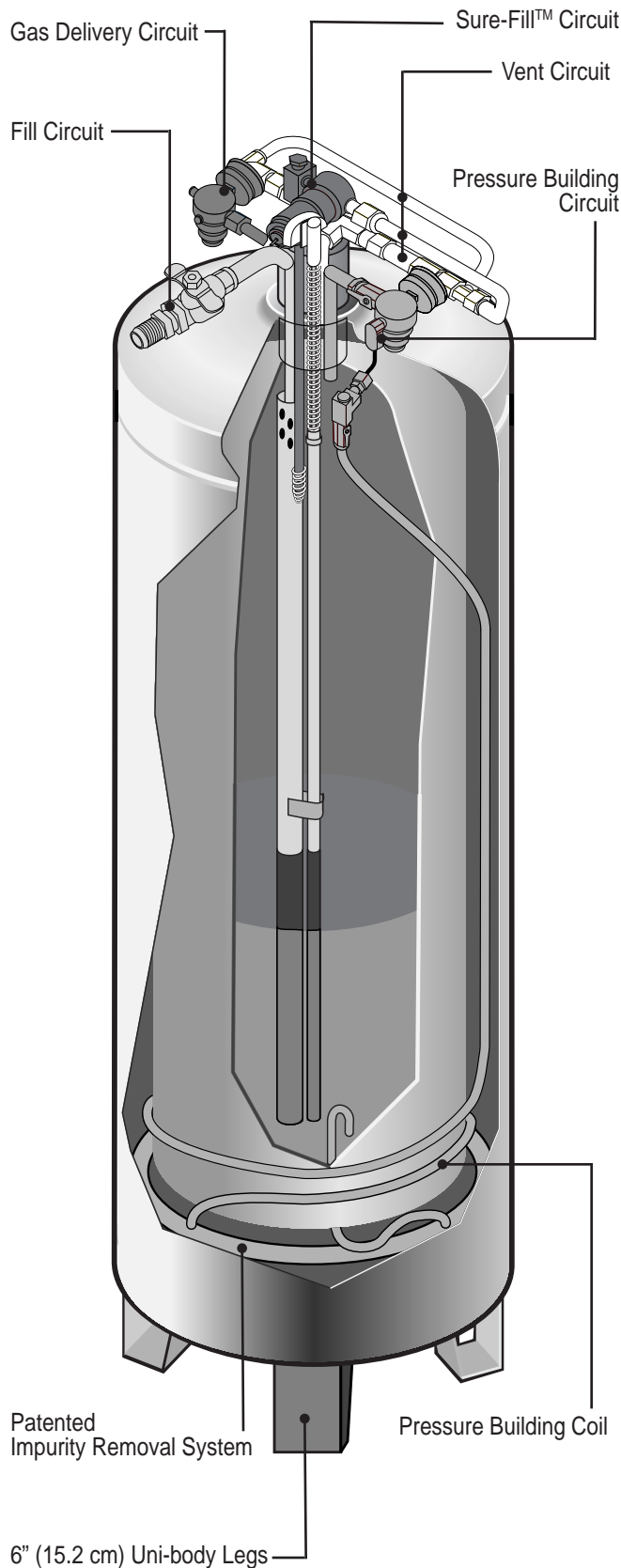

Storage Vessel

The vessel is the first of the three primary elements in a 'Carbo' series storage system. It consists of an inner vessel and an outer vessel, much like a Thermos™ bottle. The space between the two vessels contains a nearly perfect vacuum and a special insulation. The vacuum and insulation minimize the entry of unwanted heat into the liquid CO₂ stored in the inner vessel. When CO₂ gas is needed it is withdrawn from the top (gas space) of the inner vessel and dispensed to the beverage system or other use point.

Vessel Plumbing

Plumbing components on the vessel perform five functions:

- Liquid CO₂ fill
- Gas supply (Gas Delivery)
- Pressure control (Pressure Building)
- Safety vent or pressure relief (Sure-Fill & Vent)
- Pressure and contents measurement (Gauges)

The fill circuit allows liquid CO₂ to be transferred into the vessel during the delivery process. As an option, vessels in the 'Carbo' series can be equipped with the patented Sure-Fill™ assembly to optimize CO₂ fill efficiency and convenience. The gas supply circuit dispenses CO₂ gas to the beverage or other use-point system. A pressure control circuit maintains the internal vessel pressure needed to supply CO₂. The vent/relief circuit allows excess pressure to safely exit the vessel and the building. A contents and pressure gauge indicate the status of the CO₂ inside the vessel.

Fill Circuit

The stationary fill circuit consists of a brass fill fitting in the fill box, a fill hose, a valve on the vessel, and if equipped, a Sure-Fill assembly. Liquid CO₂ is transferred into the vessel through the brass fill box fitting and the fill hose. The shut-off valve on the vessel's fill port allows service to be performed on the fill-box / fill-line segment of the fill circuit without emptying the vessel.

The portable vessel's fill circuit consists of a brass fill fitting mounted to the fill tube on top of the vessel and secured with a bracket. The portable vessel is available with or without the Sure-Fill assembly.

The Sure-Fill assembly enables fast, trouble-free filling without having to manually vent excess pressure that might develop during a CO₂ delivery. The Sure-Fill automatically maintains the optimum internal vessel pressure during the fill process by venting excess pressure outdoors through the safety vent and fill box. It also automatically stops the fill process when the vessel is full.

Gas Use Circuit

Carbon dioxide gas is supplied to the use point through the gas use circuit. CO₂ gas is withdrawn from the gas space above the liquid CO₂ that is stored in the vessel. When demanded at the use point, CO₂ gas passes through the shut-off valve and into the final line regulator.

The final line regulator controls gas flow to the beverage or other use-point system. The factory setting on the final line regulator is 90 psi but the pressure may be adjusted to suit the needs of the application. The regulator is commonly set between 90 psi and 115 psi for soft drinks. Secondary pressure regulators may be added 'downstream' for applications such as bag-in-the-box, beer, or diet systems. Consult with the use-point equipment manufacturer for the correct regulator and pressure setting.

Pressure Control Circuit

The pressure control circuit, also called the "pressure building" or "PB" circuit, maintains the internal operating pressure of the vessel.

Adequate vessel pressure is needed for supplying CO₂ gas and for preventing the stored liquid carbon dioxide from changing to 'dry ice,' the solid form of CO₂.

The pressure building circuit activates to rebuild internal vessel pressure as gas is drawn from the vessel and its pressure drops below a set level.

A regulator controls the pressure building process by sensing the internal vessel pressure. When that pressure drops below the regulator's set point (factory set at 125 psi), the regulator opens allowing liquid CO₂ to flow into the vaporizer where it transforms to gas and re-pressurizes the vessel. When the internal pressure reaches the regulator's set point, the regulator closes and the flow of liquid CO₂ stops.

During the pressure building process cold liquid carbon dioxide flows through a vaporizer coil that is attached to the inside wall of the outer vessel. This cools the outside of the vessel and causes a condensation or frost ring to form near the bottom of the vessel. The appearance of a frost ring is normal when CO₂ is being used. However, if frost is present after some time when no CO₂ gas has been used, such as in the morning before the start of operations, this may indicate a CO₂ leak in a line or the beverage or other use-point system.

Safety Vent Circuit

The inner pressure vessel of this storage system is designed to meet or exceed the ASME Section VIII, Division 1 pressure vessel code. The code dictates that the vessel be protected against excess pressure by a safety relief valve. Chart uses two safety relief valves for added safety. The vessel's safety circuit is comprised of an ASME relief valve set at 300 psig and an additional relief valve set at 450 psig. The relief valves must always be vented outdoors by a vent tube, usually through the fill box, to prevent potential concentration of CO₂ within the building. The 300 psig relief valve may open during CO₂ deliveries or when CO₂ is not being used regularly.

Pressure And Contents Gauges

The vessel pressure gauge measures the pressure in the top (gas space) of the inner vessel. This pressure can normally range between 125 psig and 300 psig but the typical vessel operating pressure is 125 to 150 psig.

The vessel contents gauge measures the approximate level of CO₂ liquid in the vessel. The movement of a magnetic rod “floating” in the liquid CO₂ causes the needle on the contents gauge to move as the level of liquid CO₂ in the vessel changes.

NOTE: Because the float-rod does not actually float on the surface of the liquid CO₂ it does not provide a precise measurement of liquid CO₂ level.

CO₂ Fill Box

The stainless steel CO₂ fill box is the second major element in a typical bulk CO₂ storage system. The purpose of the fill box is to provide a convenient point to fill the storage vessel and to vent excess pressure from the vessel out of the building. The fill box has a brass fill fitting, a connection for the safety relief vent circuit, a safety snap connection point, and a lockable door. Two standard types of fill boxes are available; a surface-mount model and a flush-mount model.

Fill boxes must be mounted outside the building where they are easily accessible to the CO₂ supplier and where they can safely vent excess CO₂ pressure outdoors. When a vessel is used as a portable system, a vessel-mounted brass fill fitting and an alternative safety relief vent line are used instead of the fill box.

Fill Hose And Vent Line

The third major element of a stationary bulk CO₂ system is comprised of a fill hose and vent line. These two lines join the CO₂ storage vessel with the outdoor fill box. The fill hose, constructed with FDA compliant materials, is a pressure rated line that connects the brass fill fitting in the fill box to the fill circuit on the vessel. The vent line is as important as any component in the system. It connects the safety relief valves on the vessel to either the outdoor fill box or to an alternative outdoor vent tube.

NOTE: Whether used as stationary or as portable, the vessel must always be connected to an outdoor vent line when it contains CO₂ and is indoors.

The Bulk CO₂ Supplier

The bulk CO₂ supplier is also an important part of the system. Most CO₂ suppliers not only provide timely delivery of CO₂ but also install and service the system. For service, parts, information, emergency CO₂ delivery, or other CO₂ related assistance, contact the local Chart authorized CO₂ supplier. A place has been designated on page 19 of this manual to record the name and phone number of the CO₂ supplier and other important service contacts.

III Vessel Specifications

	Mite (200)	Charger (300)	Mizer 450
Dimensions			
Diameter	20 in (50.8 cm)	20 in (50.8 cm)	20 in (50.8 cm)
Height w/o legs (w/legs, add 6 inches)	40.1 in (101.9 cm)	51 in (129.5 cm)	65.8 in (167.0 cm)
Empty Weight	185 lb (84 kg)	216 lb (98 kg)	273 lb (124 kg)
Full Weight	356 lb (161.5 kg)	522 lb (237 kg)	726 lb (329 kg)
Net Volume	22 gal (83 liters)	32 gal (123 liters)	48 gal (182 liters)
CO ₂ Storage Capacity (saturated @ 125 psig [8.6 bar g])	201 lb (91 kg)	306 lb (139 kg)	453 lb (205 kg)
Gas Use Connection	1/4" 45° Flare	1/4" 45° Flare	1/4" 45° Flare
Fill Line Connection	5/8" Male 45° Flare	5/8" Male 45° Flare	5/8" Male 45° Flare
Vent Line Connection	1/2" OD Tubing	1/2" OD Tubing	1/2" OD Tubing
Rates and Pressures			
CO ₂ Delivery Rate Continuous*	0.75 lb/hr (.34 kg/hr) (67 - 16oz drinks / hr)	1 lb/hr (.5 kg/hr) (89 - 16oz drinks / hr)	5.5 lb/hr (2.5 kg/hr) (489 - 16oz drinks / hr)
Peak CO ₂ Delivery Rate For One Hour*	1.5 lb/hr (0.68 kg/hr) (133 - 16 oz drinks)	3 lb/hr (1.4 kg/hr) (267 - 16 oz drinks)	10.0 lb/hr (4.5 kg/hr) (889 - 16 oz drinks)
Evaporation Rate**	1.2 lb/day (0.54 kg/day)	2.0 lb/day (0.91 kg/day)	2.5 lb/day (1.1 kg/day)
Max. Allowable Working Pressure (MAWP)	300 psig (20.7 bar g)	300 psig (20.7 bar g)	300 psig (20.7 bar g)
ASME Relief Setting	300 psig (20.7 bar g)	300 psig (20.7 bar g)	300 psig (20.7 bar g)
Addl. Relief Setting	450 psig (31.0 bar g)	450 psig (31.0 bar g)	450 psig (31.0 bar g)
Sure-Fill Regulator Setting	200 psig (13.8 bar g)	200 psig (13.8 bar g)	200 psig (13.8 bar g)
Design Criteria			
All Vessels (unless noted otherwise)			
Design Specifications	ASME Section VIII, Division 1		
Design Specifications	Meets with US and Canadian approvals		
Fill System	Single Line, pressure differential		
Patented Sure-Fill System	Recommended option available on 'Charger' and 'Mizer'		
Patented Impurity Collection System	Recommended option available on 'Charger' and 'Mizer'		
Insulation Type	Vacuum with Super Insulation		
Pressure Control	Pressure Building (PB) Circuit		
Liquid Level Gauge	Float Type: Magnetic 'Roto-Cal'		
Outer Vessel Material	Stainless Steel		
Inner Vessel Material	Stainless Steel		
Floor mount Design (Meets NSF standards)	Optional Six-Inch Permanent Legs (Not available on Mizer 500)		

* Based on 11.25 lb of CO₂ / 1000 16 oz. drinks

** No loss in normal applications

IV Parts Identification

Basic Vessel (Carbo-Mite, Carbo-Charger, Carbo-Mizer)

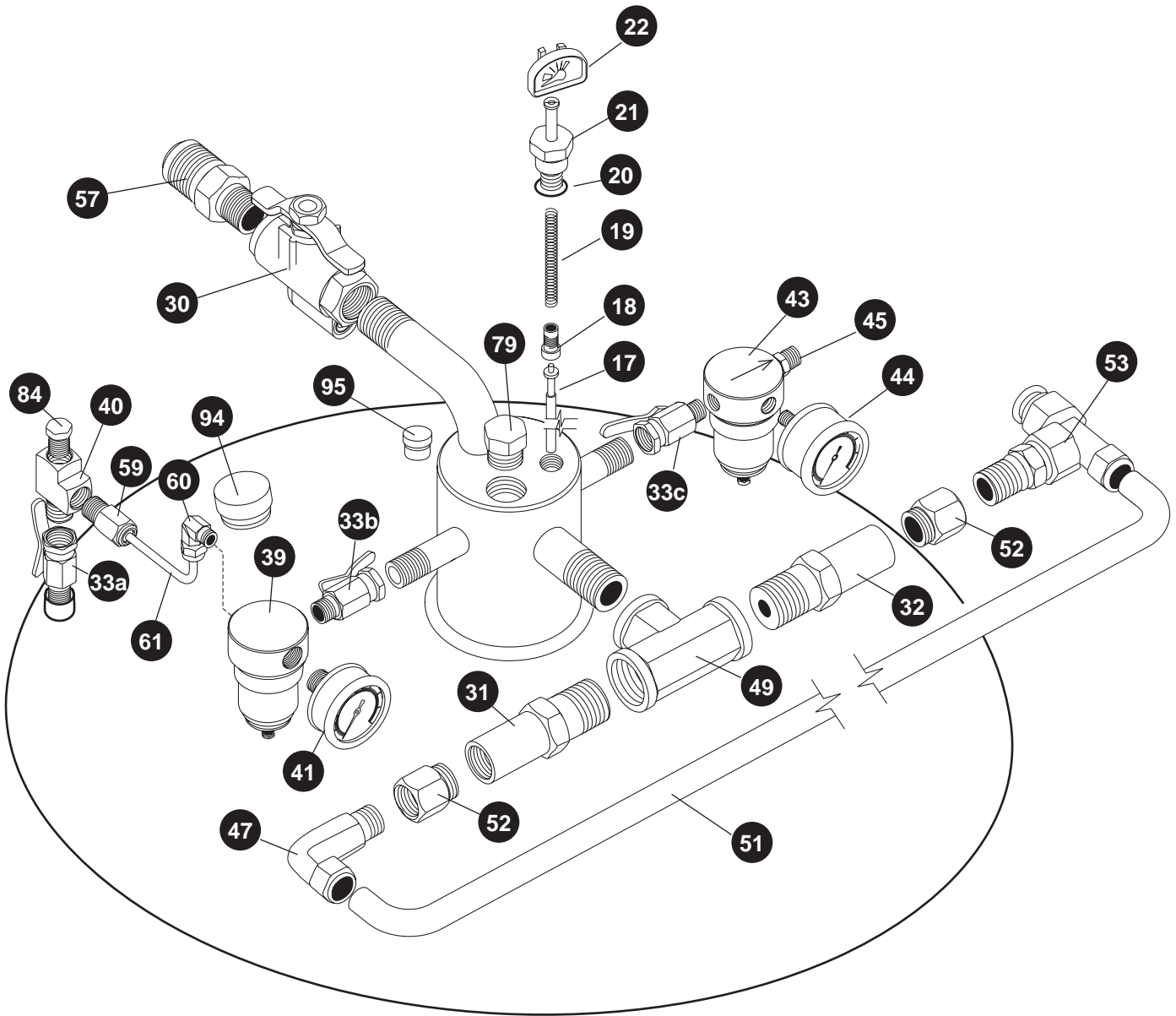

IV Parts Identification Continued

Vessels Equipped With Sure-Fill™ (Carbo-Charger, Carbo-Mizer)

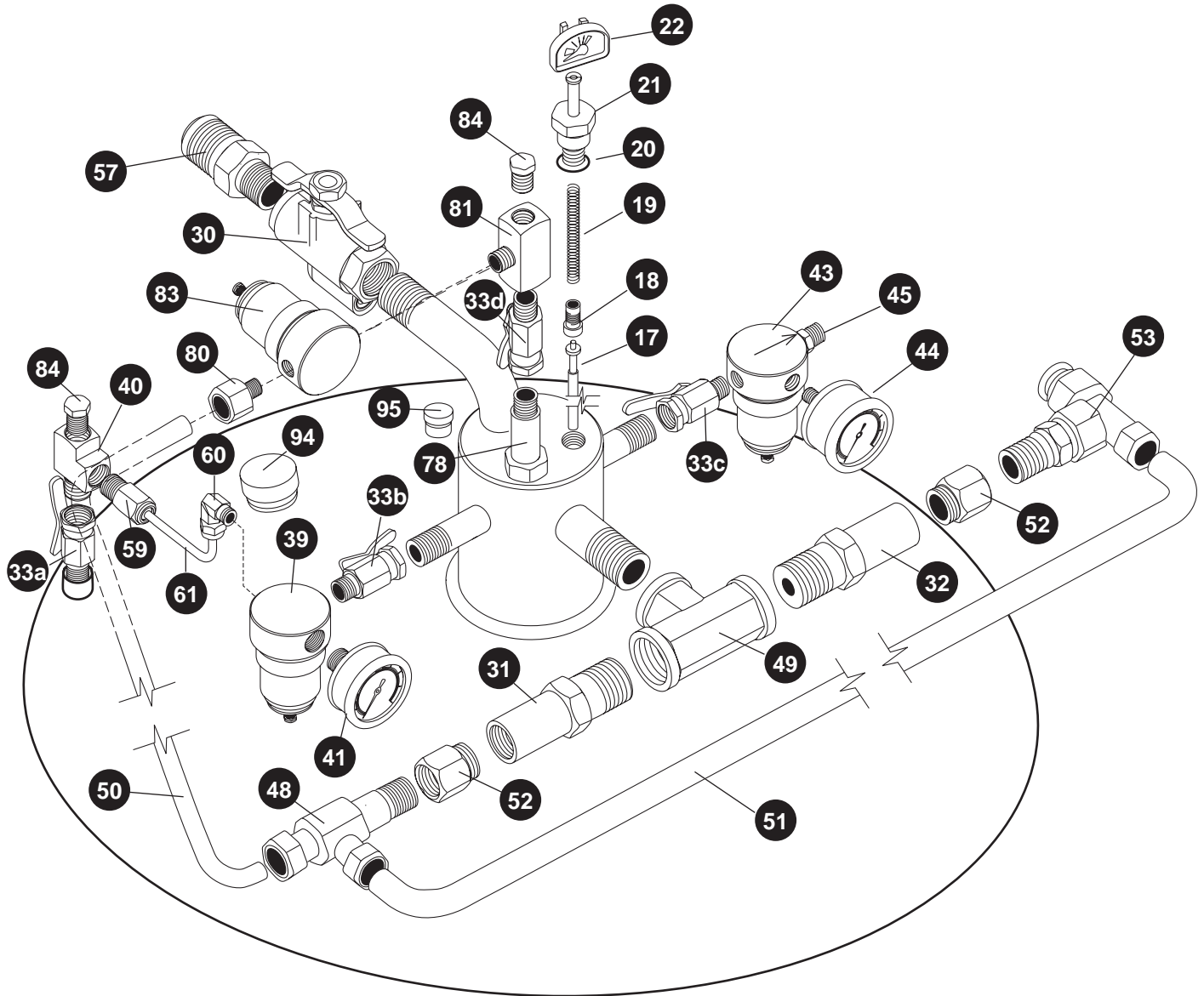

Carbo Series Storage Vessel Components

ITEM	PART NO.	DESCRIPTION	QTY	FUNCTION
17	10643106	(Mite) Float Rod Assy. (22") w/Magnet	1	Indicates liquid CO ₂ level in the vessel
17	10464811	(Charger) Float Rod Assy. (32 1/2") w/Magnet	1	Indicates liquid CO ₂ level in the vessel
17	9094119	(Mizer) Float Rod Assy. (42 1/2") w/Magnet	1	Indicates liquid CO ₂ level in the vessel
18	5411622	Spring Retainer	1	Secures spring to float rod for adjustment
19	5411029	Extension Spring	1	Provides tension on float rod
20	2300244	O-Ring, Liquid Level Gauge	1	Seals brass plug to vessel
21	5411612	Plug, Brass, Liquid Level Gauge (3/4"-16)	1	Secures the contents gauge to the vessel
-	11833139	(Mite) Liquid Level Gauge Assembly	1	Includes items 17, 18, 19, and 21
-	11043268	(Charger) Liquid Level Gauge Assembly	1	Includes items 17, 18, 19, and 21
-	10601088	(Mizer) Liquid Level Gauge Assembly	1	Includes items 17, 18, 19, and 21
22	10591369	Gauge, Liquid Level / Contents (Roto-Cal)	1	Indicates approximate liquid CO ₂ contents

IV Parts Identification Continued

Carbo Series Storage Vessel Components - Continued

ITEM	PART NO.	DESCRIPTION	QTY	FUNCTION
30	11082128	Ball Valve (3/8" FPT)	1	Isolates CO ₂ fill hose from vessel.
31	11708451	Relief Valve, 450 psig (1/2" MPT)	1	Secondary inner vessel safety relief valve
32	11708400	Relief Valve, 300 psig (1/2" MPT)	1	Primary inner vessel safety relief valve
33a	1716162	Ball Valve (1/4" MPT x 1/4" FPT)	1	Isolates liquid-side of PB regulator
33b	1716162	Ball Valve (1/4" MPT x 1/4" FPT)	1	Isolates gas-side of PB regulator
33c	1716162	Ball Valve (1/4" MPT x 1/4" FPT)	1	On / off control for gas supply
33d	1716162	Isolation Valve (1/4" MPT x 1/4" FPT)	1	Opens / closes Sure-Fill circuit
39	13041151 11768373 10569161	Regulator, (SMC) Pressure Building, 125 psi (1/4" FPT) Regulator, (MP) Pressure Building, 125 psi (1/4" FPT) Rebuild Kit For Reg. P/N 11768373 Only	1	Controls vessel pressure building (PB) circuit
40	1211702	Street Tee (1/4" PT)	1	Connects liquid-side PB isolation valve to PB line
41	13321014 2015179	Press. Gauge, 0-400 psi (1/4" MPT) For Reg. 13041151 Press. Gauge, 0-400 psi (1/4" MPT) For Reg. 11768373	1	(White face) Displays internal vessel pressure
43	13323714 11811626 9723219	Regulator, (SMC) Final Line, 90 psi (1/4" FPT) Regulator, (MP) Final Line, 90 psi (1/4" FPT) Rebuild Kit For Regulator P/N 11811626 Only	1	Controls CO ₂ gas pressure to use-point
44	13321006	Press. Gauge, 0-160 psi (1/4" MPT) For Reg. 13324714	1	(Black face) Indicates CO ₂ gas pressure to use-point
	11673631	Press. Gauge, 0-160 psi (1/8" MPT) For Reg. 11811626	1	
45	11741859	Check Valve, Gas Use	1	Protects vessel components from back flow
47	11837877	(On vessels not equipped with Sure-Fill) Elbow (1/2" OD x 3/8" MPT), Compress-Align™	1	Joins 450 psig relief valve to vent circuit on vessel without Sure-Fill
48	11837906	(On vessels equipped with Sure-Fill) Tee, Brass Run, (1/2" ODT x 3/8" MPT), Compress-Align™	1	Joins 450 psig relief valve and Sure-Fill relief to vent circuit
49	11044869	Branch Tee, (1/2" FPT)	1	Manifolds primary & secondary relief valves
50	11837885	Tube, Soft Copper Type L (1/2" OD, Nominal .375 in)	1	Sure-Fill vent tubing
51	11837893	Tube, Soft Copper Type L (1/2" OD, Nominal .375 in)	1	Primary / secondary relief valve vent tubing
52	1611592	Adapter, Pipe-Away (3/8" FPT)	2	Joins 450 & 350 psig relief valves to vent fittings
53	11741947	Branch Tee, (1/2" ODT x 3/8" MPT x 1/2" ODT), Prestolok™	1	Joins 450 & 350 psi relief valves to vent circuit
57	1110112	Connector (5/8" ODT x 3/8" MPT-45° Flare)	1	Connects CO ₂ fill hose to vessel
59	13283302	Straight Connector, (5/16" ODT x 1/4" MPT)	1	Joins PB line to street tee in PB circuit
60	13283185	Elbow Connector, (5/16" ODT x 1/4" MPT),	1	Joins PB regulator to PB line
61	5503831	Tubing, Stainless (5/16" OD)	1	Pressure builder line
78	11764313	Sure-Fill™ Tube Assembly (3/4"-16) W/O-ring	1	Controls CO ₂ filling and pressure venting
79	11811036	Plug (3/4"-16) W/O-ring [Vessel without Sure-Fill option]	1	Seals Sure-Fill port
80	11762983	Connector, Brass, (1/2" ODT x 1/4" MPT)	1	Joins Sure-Fill assembly to vent circuit
81	1213092	Tee, Brass, (1/4" FPT x 1/4" FPT x 1/4" MPT)	1	Connects Sure-Fill regulator to valve
83	13154834 1812279 10583238	Regulator, (SMC) Sure-Fill, 200 psi (1/4" FPT) Regulator, (MP) Sure-Fill, 200 psi (1/4" FPT) Rebuild Kit For Regulator P/N 1812279 Only	1	Vents excess pressure during CO ₂ filling
84	1211102	Plug, Brass (1/4")	2	Plugs access port in tee
94	3911217	Cap, Black	1	Covers vacuum pump-out port
95	3911016	Cap, Blue	1	Covers vacuum regeneration port
-	10855133	Label, Carbo-Mite	1	Denotes vessel model
-	10484985	Label, Carbo-Charger	1	Denotes vessel model
-	3817149	Label, Carbo-Mizer 400	1	Denotes vessel model
-	11799401	Label, Carbo-Mizer 450	1	Denotes vessel model
-	11799410	Label, Carbo-Mizer 500	1	Denotes vessel model
-	3836609	Label, Operations	1	Describes vessel safety and operations

IV Parts Identification Continued

Carbo Series Storage Vessel Components - Continued

ITEM	PART NO.	DESCRIPTION	QTY	FUNCTION
-	11197611	Label Kit, NYCFD Approval, (Stationary Installation)	1	Operation, caution, approval, and manufacturer
-	11197646	Label Kit, NYCFD Approval, (Portable Installation)	1	Operation, caution, approval, and manufacturer
-	3820099	Label Only, Caution Carbon Dioxide	1	Included in label kits
-	3832679	Decal Only, CO ₂ NYCFD COA #4912 (Stationary)	1	Included in label kit 11197611
-	10915896	Decal Only, CO ₂ NYCFD COA #4748 (Portable)	1	Included in label kit 11197646

Stationary Installation Components

Flush-Mount Fill Box
Part No. 9723139

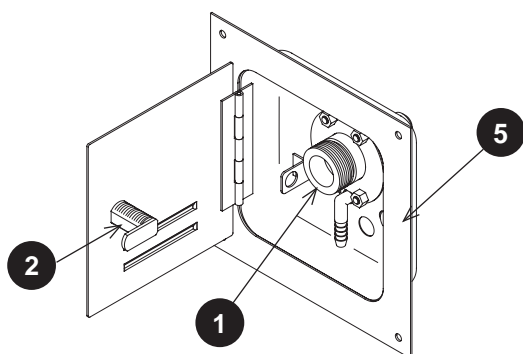

Surface-Mount Fill Box
Part No. 9722279

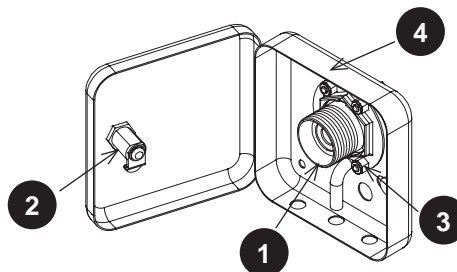

ITEM	PART NO.	DESCRIPTION	QTY.	FUNCTION
1	11381021	CO ₂ Fill Fitting, Brass	1	Connection for CO ₂ delivery vessel hose
2	4310689	Lock Assembly (includes key)	1	Locks fill box door
-	4310959	Key for Lock Assembly (not pictured)	-	Replacement key for fill box
3	2914071	Locknut SS w/nyl Insert	4	Attach fill fitting to fill box studs
4	11386771	Surface-Mount CO ₂ Fill Box (without fittings)	1	Allows outdoor filling and venting of vessel
5	11866871	Flush-Mount CO ₂ Fill Box (without fittings)	1	Allows outdoor filling and venting of vessel
-	10802912	CO ₂ Fill Hose only, 5 ft. (2000 psi & FDA)	1	Transfers liquid CO ₂ from fill box into vessel
-	10802921	CO ₂ Fill Hose only, 10 ft. (2000 psi & FDA)	1	Transfers liquid CO ₂ from fill box into vessel
-	10802947	CO ₂ Fill Hose only, 15 ft. (2000 psi & FDA)	1	Transfers liquid CO ₂ from fill box into vessel
-	10802939	CO ₂ Fill Hose only, 25 ft. (2000 psi & FDA)	1	Transfers liquid CO ₂ from fill box into vessel
-	10370710	CO ₂ Fill Hose only, 30 ft. (2000 psi & FDA)	1	Transfers liquid CO ₂ from fill box into vessel
-	10370728	CO ₂ Fill Hose only, 50 ft. (2000 psi & FDA)	1	Transfers liquid CO ₂ from fill box into vessel
-	2811726	Vent Hose (lengths match fill hose)	1	Vents excess vessel pressure outdoors

Fill and Vent Hose Kits

PART NO.	DESCRIPTION	PART NO.	DESCRIPTION
10973252	5 ft Fill & Vent Hose	10973332	25 ft Fill & Vent Hose
10973308	10 ft Fill & Vent Hose	10973341	30 ft Fill & Vent Hose
10973324	15 ft Fill & Vent Hose	10973359	50 ft Fill & Vent Hose

IV Parts Identification Continued

Portable Installation Components (Kit Part No. 11759127)

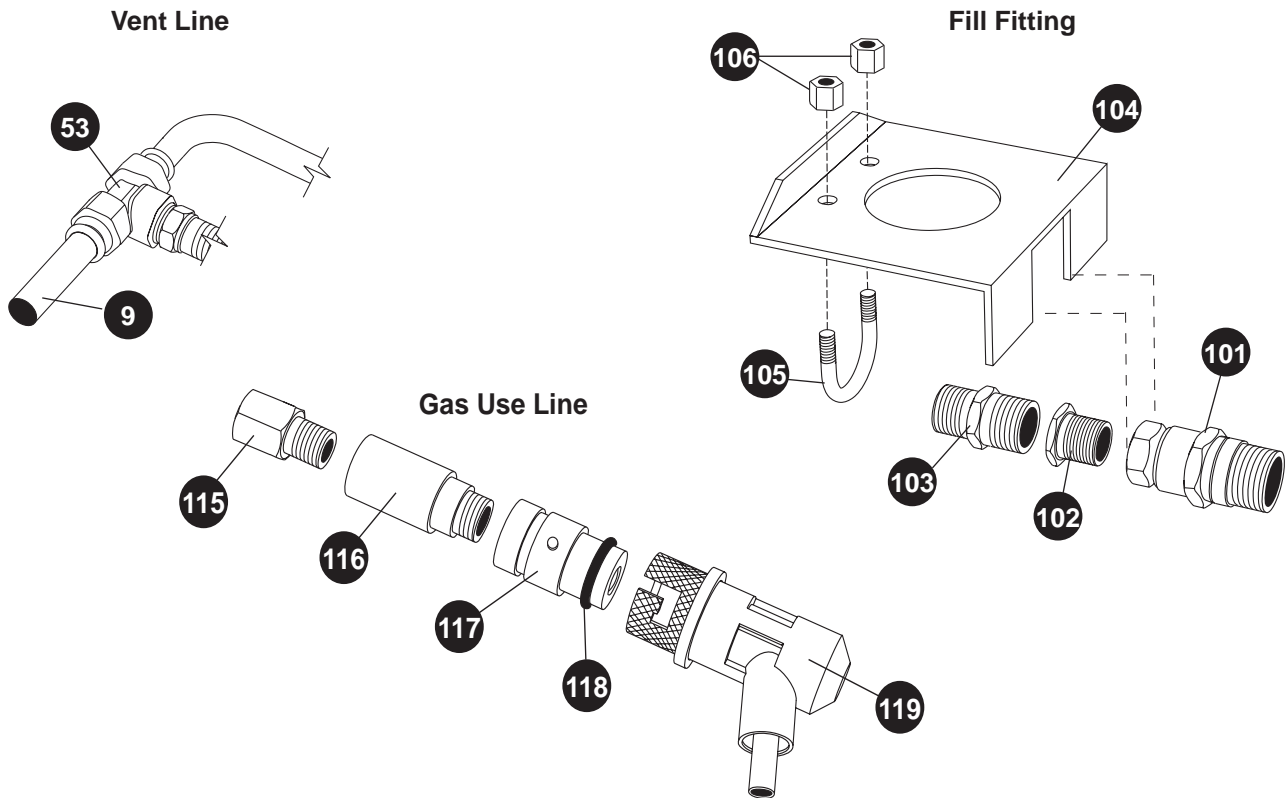

ITEM	PART NO.	DESCRIPTION	QTY.	FUNCTION
9	2811726	Vent Tubing (1/2")	15 ft	Vents excess tank pressure outdoors
30	11082128	Ball Valve (3/8" NPT) (Not included in kit. See vessel component diagram.)	1	Isolates liquid CO ₂ fill hose from vessel
53	11741947	Run Tee, (1/2" ODT x 3/8" MPT x 1/2" ODT), Prestolok™ (Vessel component. Not included in kit)	1	"Push-in" connection & release fitting for vent tube
101	10662041	CO ₂ Fill Fitting, Brass (3/4" thread)	1	Connects CO ₂ transfer hose to vessel CO ₂ fill line
102	1212062	Hex Bushing (3/8" FPT x 3/4" MPT)	1	Joins fill fitting to vessel
103	1310072	Hex Nipple (3/8" NPT x 1-1/4" long)	1	Joins fill fitting to vessel
104	10724192	CO ₂ Fill Fitting Support Bracket	1	Secures CO ₂ fill fitting to vessel
105	10644601	U-Bolt	1	Secures fill fitting bracket
106	2914071	Locking Nut	2	Secures u-bolt to fill fitting bracket
115	10808038	Connector, Brass, 45° (1/4" MPT, 1/4" ODT)	1	Connects relief valve to gas use line
116	10847854	Vessel Boss Adapter (1/4" FPT)	1	Connects 2-pin connector to gas use line
-	4710619	O-Ring For Boss Adapter (not shown) (.301" ID x .441" OD)	1	Seals boss adapter with two-pin quick connect
117	6511631	Two-Pin Quick Connect, Male	1	Allows connection & release of CO ₂ supply line
118	10526989	O-Ring (.450" ID x .658" OD)	1	Seals 2-pin connectors when joined together
119	6511706	Two-Pin Quick Connect, Female (1/4" Barb)	1	Allows connection & release of CO ₂ supply line
-	11759119	Instructions for Portable Installation	1	Describes proper procedure for fitting attachment
Not Shown	9711449	Portable Handling Cart with Towing Handle (20" OD vessels only)	1	Allows movement of portable vessels over smooth level surfaces

V Operation and Troubleshooting

Facts To Know

1. A vessel's normal internal operating pressure (Item 41) is between 125 psi and 150 psi.
2. Vessel pressure can be as high as 300 psi after a delivery, but returns to its normal operating pressure after a day or two of normal CO₂ use.
3. The gas supply pressure (Item 44) is normally between 90 psi and 120 psi.
4. Frost or condensation on the vessel is normal during periods of CO₂ use.
5. Frost or condensation on the vessel before starting the daily use of CO₂ is a sign of a CO₂ leak. Have the leak fixed.
6. A Carbo-Mite holds 171 lb of CO₂ for a use rate of 10 to 30 lb per week. A Carbo-Charger holds 306 lb of CO₂ for a use rate of 30 to 60 lb per week. Depending on model size, Carbo-Mizers hold from 415 to 500 lb of CO₂ for use rates of 40 -100 pounds per week. Refer to the table on page 6.
7. The contents gauge (Item 22) displays the approximate amount of liquid CO₂ in the vessel.
8. CO₂ becomes dry ice below a pressure of 61 psi. Stop using CO₂ from the vessel if its pressure (Item 41) reaches 70 psi or less.
9. An isolation (shut-off) valve is open when its handle is parallel to the valve body and the line. The valve is closed when its handle is perpendicular to the valve body and the line.

General Operating Instructions

1. Always use caution when working with CO₂. Read and understand the “**Safety**” section of this manual.
2. The Carbo system does not require adjustment under normal operating conditions.
3. Check the vessel daily before using CO₂. See ‘fact to know’ number 10.
4. In an emergency the flow of CO₂ from or through the Carbo-Mizer can be stopped by closing the following valves:
 - Valve 33c to stop the flow of gas from the vessel to the beverage or other use-point system.
 - Valve 30 to stop CO₂ flow or leakage through the fill hose and/or the brass fill fitting in the outdoor fill box.
 - Valve 33a and/or 33b to stop CO₂ flow through the pressure-building circuit.
5. For CO₂ equipment issues, call your CO₂ supplier or service specialist. Before calling for service or trouble shooting assistance, please have the following information at hand:
 - Serial number of the vessel
 - Description of the problem
 - Readings from:
 - the vessel contents gauge (Item 22),
 - the vessel pressure gauge (Item 41) and
 - the final line pressure gauge (Item 44).
 - Observations such as unusual frosting and/or events related to the problem.
6. Every day before starting operations and CO₂ use check for:
 - CO₂ leaks (See “**Safety**”.)
 - Pressure readings (Items 41 and 44)
 - CO₂ contents (Item 22)
 - Abnormal frost or condensation
 - Anything unusual.

V Operation and Troubleshooting

CO₂ Storage Vessel

INDICATION	POSSIBLE CAUSE	CORRECTIVE ACTION
No CO ₂ to carbonator or other use-point system. OR Carbonated drinks are flat.	CO ₂ storage vessel is empty.	1. Switch to emergency CO ₂ gas cylinder. 2. Call CO ₂ supplier for delivery.
	Isolation valve (33c) to final line regulator is closed.	Open valve or valves as needed.
	Vessel pressure (41) is low (110 psi or less).	1. Switch to emergency CO ₂ gas cylinder. 2. Stop CO ₂ withdrawal from bulk CO ₂ vessel by closing isolation valve 33c. 3. If vessel pressure fails to rebuild see section on low vessel pressure.
	Pressure building regulator (39) not operating properly	1. Ensure that isolation valves (33a & b) are open. 2. Valve handles should be parallel with the line. 3. Regulator is set too low, plugged, or faulty. Call CO ₂ service agent.
	Unknown	Call CO ₂ service agent.
Frost on the bottom or sides of the vessel.	A normal condition during or following CO ₂ use.	None
	Leak in beverage system and/or gas supply lines or CO ₂ fill box. (When frost is present after extended periods of no CO ₂ use.)	1. See "Safety". Evacuate & ventilate. Check for frost in the morning before CO ₂ has been used. If possible, locate and correct leak. 2. Call appropriate equipment service agent.
Frost on the top of the vessel.	Normal condition during periods of CO ₂ use.	None
	CO ₂ leak from the beverage system, vessel's plumbing, or CO ₂ fill box. (Frost present after extended periods with no intentional CO ₂ use.)	1. See "Safety". Evacuate & ventilate the room. 2. Check for frost in the morning before CO ₂ use. Other indicators include high CO ₂ usage, frost on sides of the vessel, low vessel pressure, etc. Locate & correct leak if possible. 3. Call appropriate service agent.
Constant low vessel pressure. (gauge 41 below 125 psi)	PB regulator (39) set low or plugged.	Call CO ₂ service agent for service.
	PB shut-off valve (33a & b) closed.	Open valve by turning handle parallel to line.
	CO ₂ leak from vessel plumbing, CO ₂ fill box and/or vessel safety system	1. See "Safety". Evacuate & ventilate the room. 2. Call CO ₂ service agent.

V Operation and Troubleshooting

CO₂ Storage Vessel

INDICATION	POSSIBLE CAUSE	CORRECTIVE ACTION
Constant high vessel pressure. (41 over 200 psi)	Normal condition for a few days following a CO ₂ delivery.	None
	Normal when little or no CO ₂ is used.	None
	PB regulator (39) set too high.	Call CO ₂ service agent.
	Vessel has a weak vacuum.	Call CO ₂ service agent.
High CO ₂ consumption.	Increased beverage sales or CO ₂ use.	None
	Vessel pressure (41) constantly high.	See section on vessel pressure too high.
	CO ₂ leak from vessel plumbing, CO ₂ fill box, gas lines, and/or beverage or other use-point equipment.	<ol style="list-style-type: none"> 1. See “Safety”. Evacuate & ventilate room. 2. Locate & correct leak if possible 3. Call appropriate service agent.
	Error in CO ₂ supplier invoice.	Check CO ₂ usage history / pattern against supplier invoices. Consult CO ₂ supplier.
CO ₂ vessel will not fill.	CO ₂ vessel is already full.	None
	Fill valve (30) is shut off or is faulty.	Consult CO ₂ service agent.
	Brass fill fitting in CO ₂ fill box and/or on truck’s delivery hose is faulty.	<ol style="list-style-type: none"> 1. Consult with CO₂ supplier or service agent. 2. Have brass fill fitting(s) replaced if needed.
	Differential between store vessel pressure and delivery pressure is too small. (At start of fill, store vessel pressure should be 110 - 150 psi and delivery vessel pressure should be 275 - 300 psi).	<ol style="list-style-type: none"> 1. Verify delivery vessel pressure is at least 275 psi and store vessel pressure (41) is between 110 and 150 psi. 2. Vent store vessel to lower pressure if needed. 3. Never vent store vessel pressure to lower than 125 psi.
	Sure Fill™ assembly does not vent gas because vessel pressure did not return to normal operating pressure.	<ol style="list-style-type: none"> 1. Vessel pressure must drop below 200 psi between filling times to allow the ‘check’ ball to fall into the open position. 2. Consult CO₂ service agent.
	Leak in Sure Fill™ assembly / regulator. (Pressure above check ball is lower than vessel pressure.)	<ol style="list-style-type: none"> 1. Close valve at PB regulator for several minutes allowing pressure above check ball to equalize and ball to fall into the open position. 2. Contact CO₂ supplier.
	Delivery vessel is empty.	Consult supplier. Arrange for another delivery.
	Delivery vessel empty or truck delivery hose is obstructed, e.g. vehicle stopped on hose or hose is bent.	Ask driver to make another delivery or clear obstruction or wait until obstruction clears.

V Operation and Troubleshooting

CO₂ Storage Vessel

INDICATION	POSSIBLE CAUSE	CORRECTIVE ACTION
Hissing sounds or evidence of gas leak.	Normal for short periods of time from some regulators and relief valves.	Observe leak, if it is not large <u>and</u> does not last long <u>and</u> occur frequently, no action is needed.
	Large leaks from elsewhere in the system, sustained leaks, or frequent leaks are not normal.	<ol style="list-style-type: none"> 1. See "Safety". 2. Evacuate all personnel from affected areas. 3. Ventilate the area. 4. Call CO₂ service agent.
Final line / gas use pressure gauge (44) indicates less than 90 psi.	Final line regulator (43) intentionally set lower by beverage service agent.	None
	Final line regulator (43) not operating in proper pressure range.	Call CO ₂ service agent.
	Final line pressure gauge (44) damaged or faulty.	Call CO ₂ service agent.
	One or more of the causes listed in "no CO ₂ " or "flat drinks" problem section.	<ol style="list-style-type: none"> 1. See indication sections regarding "no CO₂", "flat drinks" etc. 2. Call CO₂ service agent.

V Operation and Troubleshooting

Fill Box

INDICATION	POSSIBLE CAUSE	CORRECTIVE ACTION
Fill box door will not close, lock, or open.	Wrong key.	<ol style="list-style-type: none"> 1. Verify correct key and retry. 2. Contact CO₂ supplier for spare key. 3. Order new key.
	Lock dirty or damaged.	<ol style="list-style-type: none"> 1. Clean and oil lock 2. Replace lock if necessary
Brass fill fitting in fill box leaking or hissing.	Particle of ice or debris caught in fill fitting poppet.	<ol style="list-style-type: none"> 1. If driver is still on site, reconnect CO₂ delivery hose and then disconnect. 2. If driver is not available, carefully press poppet with dull instrument to re seat poppet. 3. If leak continues after line warms, close the fill isolation valve (30) and call service agent.
	Fitting is defective or sealing surface is worn due to normal wear.	Close the fill isolation valve (30) on the vessel and call service agent to replace fitting.
Threads on brass fill fitting are worn or stripped.	Normal wear. Fill fitting must be replaced.	Contact CO ₂ service agent to replace fitting.
	Fill fitting cross threaded with the CO ₂ delivery hose coupler	Contact CO ₂ service agent to replace fitting.
CO ₂ is venting from fill box.	Normal during CO ₂ delivery.	None
	Normal for short periods of time if vessel pressure is at or over 300 psi	<ol style="list-style-type: none"> 1. NONE if for short period(s) of time 2. If vessel pressure consistently over 300 psi, see section on vessel pressure too high.
	Fill fitting is not sealing properly.	Call CO ₂ service agent to replace fitting.

VI Ordering Service and Parts

Service and Maintenance

1. Service or maintenance work on the MVE bulk CO₂ storage system should be performed only by Chart trained and authorized professional service agents who are familiar with CO₂, bulk liquid CO₂ pressure vessels, and all pertinent safety and service procedures. Chart recommends the use of Chart approved replacement parts. Contact Chart for the name of the authorized service agent(s) in your area.
2. Before calling for service or troubleshooting assistance, please have the following information at hand:
 - Serial number of the vessel
 - Description of the problem
 - Readings from:
 - the contents gauge (Item 22),
 - the vessel pressure gauge (Item 41)
 - the final line pressure gauge (Item 44).
 - Any special observations (for example: unusual frosting or events related to the problem)
3. Chart recommends that a qualified professional service agent perform a

thorough preventative maintenance check on the system at least once every two years.

The check should be done to ensure safety and optimal system performance.

4. The MVE bulk CO₂ storage system has no user serviceable parts. An authorized professional service agent should perform all service work.

NOTE: Any attempt by an unauthorized person to service or perform unauthorized modifications on the equipment will void the warranty.

Ordering Parts Or Service

For service contact your local authorized MVE CO₂ supplier or equipment service agent. For parts contact your local authorized Chart service agent or order on-line directly from Chart at www.chartparts.com. Know the model and serial number of the vessel for which you are ordering parts. To assure that your order is processed promptly, list each item separately, being careful to specify the quantity, the part number, and the description of each item being ordered.

Important Telephone Numbers

Company	Contact Person	Phone Number
CO ₂ Supplier	_____	_____
	<u>After-Hours / Emergency Number</u> _____	
CO ₂ Service Agent	_____	_____
CO ₂ Equipment Installer	_____	_____
MVE Customer Service	(952) 758-4484 or (800) 247-4446 {toll free in US}	
MVE Technical Service	(952) 758-4484 or (800) 253-1769 {toll free in US}	

VI Warranty

WARRANTY POLICY

Chart Industries, Inc. warrants to the Purchaser the Carbo series bulk CO₂ system equipment for 90 (ninety) days from the Chart invoice date, that said equipment shall be free from any defects in workmanship and materials. Chart also warrants the reliability of the vacuum in the CO₂ storage vessel for 5 (five) years and **“Pool Coat” vessels for 3 (three) years** from the date of the original Chart invoice.

Purchaser agrees that as a pre-condition to any Chart liability hereunder, Purchaser or its appointed agents shall fully inspect all goods immediately upon delivery and shall give Chart written notice of any claim or purported defect within ten (10) days after discovery of such defect.

As a further pre-condition to any Chart liability hereunder, an approved Chart service company must supply both parts replacement and labor. Chart may elect to repair or replace such equipment or any defective component or part thereof which proves to be defective, or to refund the purchase price paid by the original Purchaser. Chart shall not be liable for defects caused by the effects of normal wear and tear, erosion, corrosion, fire, explosion, misuse, or unauthorized modification.

Alterations or repair by others than those designated and approved by Chart or operation of such equipment in a manner inconsistent with Chart accepted practices and all operating instructions, unless pre-authorized in writing by Chart, shall void this Warranty.

Chart's sole and exclusive liability under this Warranty is to the Purchaser and shall not exceed the lesser of the cost of repair, cost of replacement, or refund of the net purchase price paid by the original Purchaser.

Chart is not liable for any losses (including CO₂), damages, or costs of delays, including incidental or consequential damages. Chart specifically makes no warranties or guarantees, expressed or implied, including the warranties of merchantability or fitness for a particular purpose or use, other than those warranties expressed herein.

WARRANTY CLAIMS PROCEDURE

1. All warranty claims must be previously authorized by: Chart Ind., Inc. Telephonic / electronic approval may be obtained by contacting Chart's MVE Beverage Systems Technical / Customer Services at:

- Telephone: 952-758-4484
800-247-4446
800-253-1769
(Toll free in U.S.)
- Facsimile: 952-758-8275

or by writing to:
Chart Industries, Inc.
MVE Beverage Systems
Storage Systems Division
407 Seventh Street NW
New Prague, MN 56071-1000
USA

2. Authorization must be obtained from Chart prior to shipping any equipment to Chart facilities. In order to process the return of a vessel its model and serial number must be provided. If approved, a Return Material Authorization (RMA) number will be provided. The RMA number must be prominently indicated on the packing slip and any packaging that accompanies the goods being returned. The customer returning the goods is responsible for all freight, proper packing, and any damage incurred during shipment of the goods back to Chart.

VIII System Flow Schematic

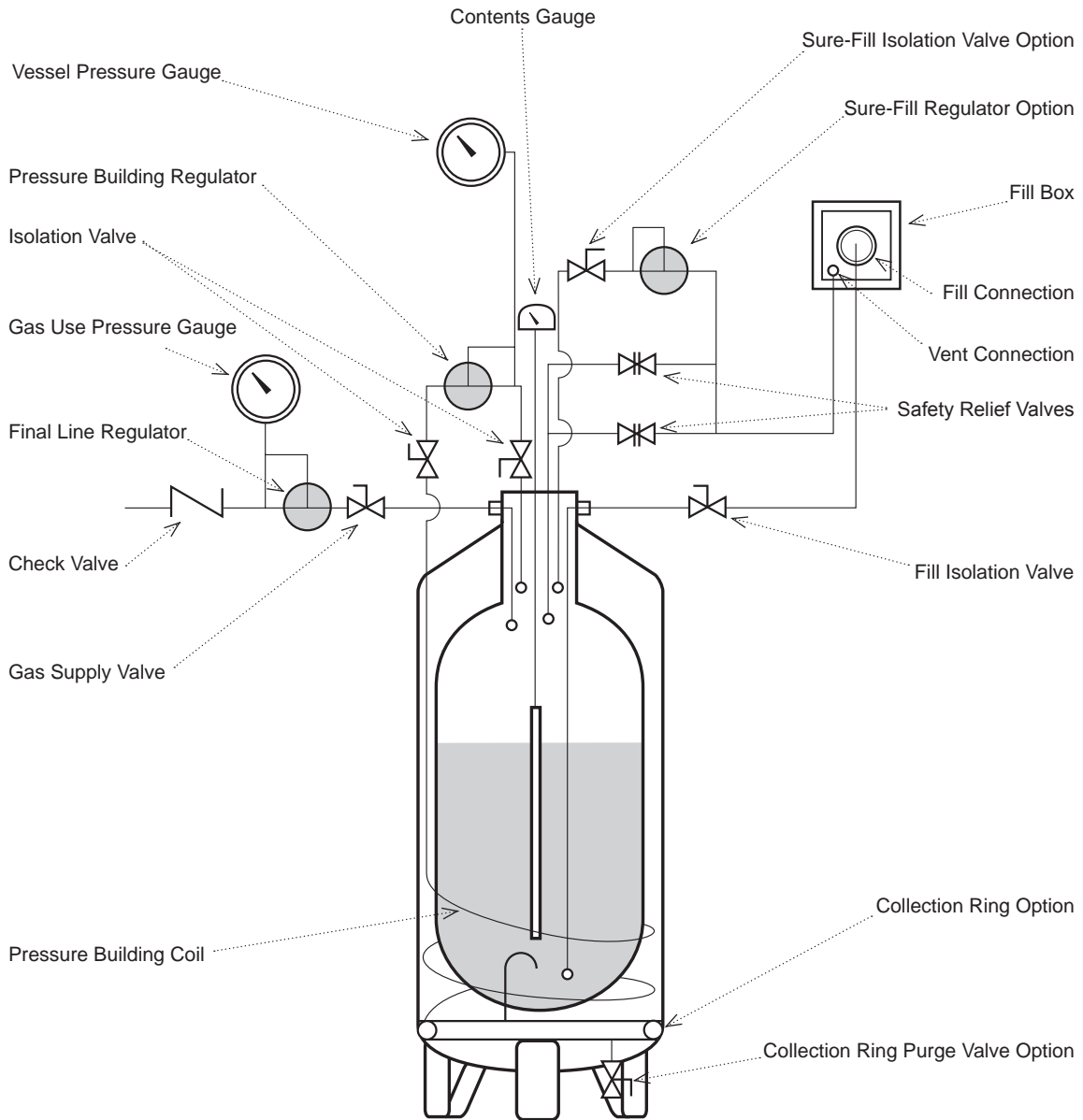

MVE Carbo Series
CO₂ System

chartparts.com

- Order parts directly from Chart through a personalized account at **www.chartparts.com**.
- Simply establish an account password and “log-in.”
- Service is available 24 hours a day and provides same-day shipping on all stock parts.
- Chartparts provides access to shipment tracking, transaction history, and personalized account information for convenient account management.

Chart Industries, Inc.
407 7th Street N.W.
New Prague, MN 56071-1000



chartbeverage.com

Copyright © 2004 Chart Industries
PART NUMBER 11807934 Rev. 6, 09/05

U.S. 800-247-4446 • Worldwide 952-758-4484 • Fax 952-758-8275 • www.chart-ind.com • email: beverage@chart-ind.com