

TRIFECTA GAS SUPPLY SYSTEM
OPERATIONAL USERS' MANUAL

TABLE OF CONTENTS

GENERAL	1
SYSTEM SPECIFICATIONS	1
Flow	1
Electrical	1
SAFETY	2
Safety Summary	2
Safety Bulletin	3
INSTALLATION	7
Placement of Skid	7
Plumbing to Bulk Tank	7
Plumbing to Vaporizer	8
Bulk Tank Pressure Transmitter	9
Plumbing	9
Electrical	9
Electrical Power Supply	10
Commissioning	10
OPERATION	12
Automatic Mode	12
PLC Controller Interface	13
Changing Parameters	14
Manual Mode	14
REPLACEMENT PARTS	17
Solenoid Valves	17
Pressure/Differential Pressure Transmitters	17
Laser-Cyl Pressure Safety Devices	17
Line Relief Valves	18
Fuses	18
Resistor Elements	19
Relays	19
TROUBLESHOOTING	20
Sensor Error Check	20

Sensor Error Solutions _____	20
Product Delivery _____	21
Checking Transmitter Output _____	21
Pressure Transmitter _____	23
Differential Pressure Transmitter _____	23
Checking Resistor Values _____	24
Recommended Spares _____	24
WARRANTY _____	25
DRAWING APPENDIX _____	26
C-10928849 _____	26
D-10923562 sheet 2 and sheet 4 _____	26

TABLE OF FIGURES

Figure 1 - System Flow Curve _____	1
Figure 2 - Plumbing Connection Points _____	8
Figure 3 - Field Wiring Diagram _____	10
Figure 4 - System Front View _____	12
Figure 5 - Valve Identification _____	16
Figure 6 - Fuse Location Diagram _____	19
Figure 7 - Relay Identification Drawing _____	20
Figure 8 - Input Channel Location on the PLC _____	22

LIST OF TABLES

Table 1 - Valve Operating Positions _____	13
Table 2 - Configurable Values _____	14
Table 3 - Valve Identification _____	16
Table 4 - Solenoid Valves _____	17
Table 5 - Solenoid Valve Repair Kits _____	17
Table 6 - Transmitters _____	17
Table 7 - Line Relief Valves _____	18
Table 8 - Line Relief Valves _____	18
Table 9 - Fuses _____	18
Table 10 - Resistor Elements _____	19
Table 11 - Relays _____	19
Table 12 - Troubleshooting _____	21
Table 13 - PLC Input Channels _____	22

Table 14 - Resistor Removal Terminals _____ 24
 Table 15 - Recommended Spares _____ 24
 Table 16 - Component Manufacture's Warranties _____ 25

REVISION	DESCRIPTION
REV #1 (2/4/98)	Replace relief valve (10908101) with (11030264) per ECO #11007.

GENERAL

Congratulations, you now own MVE, Inc.'s TRIFECTA. high pressure gas supply system. This system is designed to utilize a standard, low pressure cryogenic bulk tank to produce the high pressure and flow rate gas that is being demanded by today's laser systems. The system is designed to provide a continuous flow of high pressure gas with no interaction from the user. The user simply needs to maintain liquid in the bulk tank, and TRIFECTA's controls system will manage the rest.

SYSTEM SPECIFICATIONS

FLOW

The TRIFECTA. gas supply system is capable of supplying a continuous nitrogen gas flow rate at higher pressures than standard cryogenic bulk storage tanks. If the customer can tolerate lower delivery pressures, the TRIFECTA. system will deliver greater flow rates. If the customer can tolerate lower flow rates, the TRIFECTA. system will deliver at higher pressures. The following curve is an approximation of the flow rate and delivery pressure relationship:

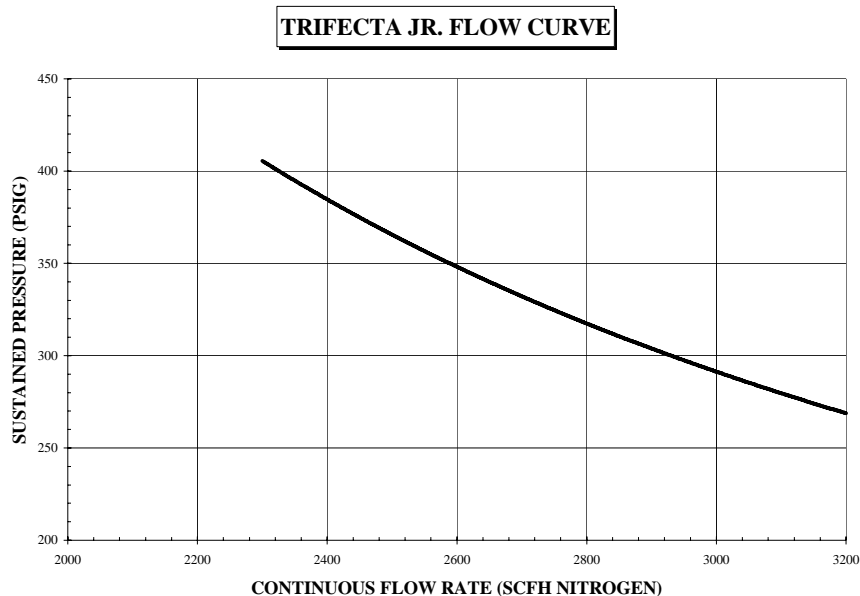

Figure 1 - System Flow Curve

ELECTRICAL

The system has an electrical requirement of 20A that breaks down as follows:

(8) Solenoid valves @ 2.5A each = 20A¹

Controls @ 1A

The electrical supply voltage should be 110 vac.

¹ The solenoid valves have a 2.5 Amp peak load, 1 Amp continuous load.

SAFETY

As with any cryogenic system, it should be observed that any non-insulated piping can get extremely cold and should not be touched by exposed skin. If the system requires maintenance, it should be shut-down and allowed to warm-up.

If maintenance is to be done on the system, such as changing valve seats, it is extremely important that the pressure be relieved from the system through the vent valves. The system pressures and liquid levels can be monitored by the five transmitters.

When doing maintenance on the system, it is recommended that the manual isolation valves to the bulk tank are closed.

SAFETY SUMMARY

Strict compliance with proper safety and handling practices is necessary when using a cryogenic system. We recommend that all our customers re-emphasize safety and safe handling practices to all their employees and customers. While every possible safety feature has been designed into the unit and safe operations are anticipated, it is essential that the user of the cryogenic system carefully read to fully understand all WARNINGS and CAUTION notes listed in this safety summary and enumerated below. Also read the information provided in the Safety Bulletin for Oxygen and Inert Gases following this Safety Summary. Periodic review of the Safety Summary is recommended.

In an oxygen enriched atmosphere, flammable items burn vigorously and could explode. Excess accumulation of oxygen creates an oxygen enriched atmosphere (defined by the Compressed Gas Association as an oxygen concentration above 23%). Certain items considered non-combustible in air may burn rapidly in such an environment. Keep all organic materials and other flammable substances away from possible contact with oxygen; particularly oil, grease, kerosene, cloth, wood, paint, tar, coal, dust, and dirt which may contain oil or grease. Do not permit smoking or open flame in any area where oxygen is stored, handled, or used. Failure to comply with this warning may result in serious personal injury.

Nitrogen and argon vapors in air may dilute the concentration of oxygen necessary to support or sustain life. Exposure to such an oxygen deficient atmosphere can lead to unconsciousness and serious injury, including death.

Before removing any parts or loosening fittings, empty the cryogenic container of liquid contents and release any vapor pressure in a safe manner. External valves and fittings can become extremely cold and may cause painful burns to personnel unless properly protected. Personnel must wear protective gloves and eye protection whenever removing parts or loosening fittings. Failure to do so may result in personal injury due to the extreme cold and pressure in the tank.

Accidental contact of liquid gases with skin or eyes may cause a freezing injury

similar to a burn. Handle liquid so that it will not splash or spill. Protect your eyes and cover skin where the possibility of contact with liquid, cold pipes and equipment, or cold gas exists. Safety goggles or a face shield should be worn if liquid ejection or splashing may occur or cold gas may issue forcefully from equipment. Clean, insulated gloves that can be easily removed and long sleeves are recommended for arm protection. Cuffless trousers should be worn over the shoes to shed spilled liquid.

If clothing should be splashed with liquid oxygen it will become highly flammable and easily ignited while concentrated oxygen remains. Such clothing must be aired out immediately, removing the clothing if possible, and should not be considered safe for at least 30 minutes.

Use only replacement parts that are compatible with liquid oxygen and have been cleaned for oxygen use. Do not use regulators, fittings, hoses, etc., which have been previously used in a compressed air environment. Similarly, do not use oxygen equipment for compressed air. Failure to comply with these instructions may result in serious damage to the container.

Before locating oxygen equipment, become familiar with the National Fire Protection Association (NFPA) standard No. 50, "Bulk Oxygen Systems at Customer Sites", and with all local safety codes. The NFPA standard covers general principles recommended for installing bulk oxygen systems on industrial and institutional consumer premises.

To prevent possible tip over, do not leave tank standing upright unless it is secured to its foundation (bolted down). Transporting and erection of the tank should be performed in accordance with rigging instructions available from MVE. Failure to comply with these instructions may result in serious damage to the container.

SAFETY BULLETIN

Portions of the following information is extracted from Safety Bulletin SB-2 from the Compressed Gas Association, Inc. (CGA). Additional information on nitrogen and argon and liquid cylinders is available in CGA Pamphlet P-9. Write to the Compressed Gas Association, Inc., 1235 Jefferson Davis Highway, Arlington, VA 22202.

From CGA Safety Bulletin

Cryogenic containers, stationary or portable, are from time-to-time subjected to assorted environmental conditions of an unforeseen nature. This safety bulletin is intended to call attention to the fact that whenever a cryogenic container is involved in any incident whereby the container or its safety devices are damaged, good safety practices must be followed. The same holds true whenever the integrity or function of a container is suspected of abnormal operation.

Good safety practices dictate that the contents of a damaged or suspect container be carefully emptied as soon as possible. Under no circumstances should a damaged container be left with product in it for an extended period of time. Further, a damaged or

suspect container should not be refilled unless the unit has been repaired and re-certified.

Incidents which require that such practices be followed include: highway accidents, immersion in water, exposure to extreme heat or fire, and exposure to most adverse weather conditions (earthquakes, tornadoes, etc.). As a rule of thumb, whenever a container is suspected of abnormal operation, or has sustained actual damage, good safety practices must be followed.

In the event of known or suspected container vacuum problems (even if an extraordinary circumstance such as those noted above has not occurred), do not continue to use the unit. Continued use of a cryogenic container that has a vacuum problem can lead to embrittlement and cracking. Further, the carbon steel jacket could possibly rupture if the unit is exposed to inordinate stress conditions caused by an internal liquid leak.

Prior to reusing a damaged container, the unit must be tested, evaluated, and repaired as necessary. It is highly recommended that any damaged container be returned to MVE for repair and re-certification.

The remainder of this safety bulletin addresses those adverse environments that may be encountered when a cryogenic container has been severely damaged. These are oxygen deficient atmospheres, oxygen enriched atmospheres, and exposure to inert gases.

OXYGEN DEFICIENT ATMOSPHERES

The normal oxygen content of air is approximately 21%. Depletion of oxygen content in air, either by combustion or by displacement with inert gas, is a potential hazard and users should exercise suitable precautions.

One aspect of this possible hazard is the response of humans when exposed to an atmosphere containing only 8 to 12% oxygen. In this environment, unconsciousness can be immediate with virtually no warning.

When the oxygen content of air is reduced to about 15 or 16%, the flame of ordinary combustible materials, including those commonly used as fuel for heat or light, may be extinguished. Somewhat below this concentration, an individual breathing the air is mentally incapable of diagnosing the situation because the onset of symptoms such as sleepiness, fatigue, lassitude, loss of coordination, errors in judgment and confusion can be masked by a state of "euphoria," leaving the victim with a false sense of security and well being.

Human exposure to atmosphere containing 12% or less oxygen leads to rapid unconsciousness. Unconsciousness can occur so rapidly that the user is rendered essentially helpless. This can occur if the condition is reached by immediate change of environment, or through the gradual depletion of oxygen.

Most individuals working in or around oxygen deficient atmospheres rely on the "buddy system" for protection - obviously, the "buddy" is equally susceptible to asphyxiation if he or she enters the area to assist an unconscious partner unless equipped with a portable air supply. Best protection is obtainable by equipping all individuals with a portable supply of respirable air. Life lines are acceptable only if the area is essentially free of obstructions and individuals can assist one another without constraint.

If oxygen deficient atmosphere is suspected or known to exist:

1. Use the "buddy system." Use more than one "buddy" if necessary to move a fellow worker in an emergency.
2. Both the worker and "buddy" should be equipped with self-contained or air line breathing equipment.

OXYGEN ENRICHED ATMOSPHERES

An oxygen enriched atmosphere occurs whenever the normal oxygen content of air is allowed to rise above 23%. While oxygen is non-flammable, ignition of combustible materials can occur more readily in an oxygen-rich atmosphere than in air; and combustion proceeds at a faster rate although no more total heat is released.

It is important to locate an oxygen system in a well-ventilated location since oxygen-rich atmospheres may collect temporarily in confined areas during the functioning of a safety relief device or leakage from the system.

Oxygen system components, including but not limited to, containers, valves, valve seats, lubricants, fittings, gaskets and interconnecting equipment including hoses, shall have adequate compatibility with oxygen under the conditions of temperature and pressure to which the components may be exposed in the containment and use of oxygen. Easily ignitable materials shall be avoided unless they are parts of equipment or systems that are approved, listed, or proved suitable by tests or by past experience.

Compatibility involves both combustibility and ease of ignition. Materials that burn in air may burn violently in pure oxygen at normal pressure, and explosively in pressurized oxygen. In addition, many materials that do not burn in air may do so in pure oxygen, particularly when under pressure. Metals for containers and piping must be carefully selected, depending on service conditions. The various steels are acceptable for many applications, but some service conditions may call for other materials (usually copper or its alloys) because of their greater resistance to ignition and lower rate of combustion.

Similarly, materials that can be ignited in air have lower ignition energies in oxygen. Many such materials may be ignited by friction at a valve seat or stem packing, or by adiabatic compression produced when oxygen at high pressure is rapidly introduced into a system initially at low pressure.

NITROGEN AND ARGON

Nitrogen and argon (inert gases) are simple asphyxiants. Neither gas will support or sustain life and can produce immediate hazardous conditions through the displacement of oxygen. Under high pressure these gases may produce narcosis even though an adequate oxygen supply, sufficient for life, is present.

Nitrogen and argon vapors in air dilute the concentration of oxygen necessary to support or sustain life. Inhalation of high concentrations of these gases can cause anoxia, resulting in dizziness, nausea, vomiting, or unconsciousness and possibly death. Individuals should be prohibited from entering areas where the oxygen content is below 19% unless equipped with a self-contained breathing apparatus. Unconsciousness and death may occur with virtually no warning if the oxygen concentration is below approximately 8%. Contact with cold nitrogen or argon gas or liquid can cause cryogenic (extreme low temperature) burns and freeze body tissue.

Persons suffering from lack of oxygen should be immediately moved to areas with normal atmospheres. **SELF CONTAINED BREATHING APPARATUS MAY BE REQUIRED TO PREVENT ASPHYXIATION OF RESCUE WORKERS.** Assisted respiration and supplemental oxygen should be given if the victim is not breathing. If cryogenic liquid or cold boil-off gas contacts a worker's skin or eyes, the affected tissues should be promptly flooded or soaked with tepid water (105-115°F; 41-46°C). **DO NOT USE HOT WATER.** Cryogenic burns which result in blistering or deeper tissue freezing should be examined promptly by a physician.

MVE customer stations are safely designed with the following features:

1. A vacuum maintenance system specifically designed to provide long life and all possible safety provisions.
2. Safety relief devices to protect the pressure vessel and vacuum casing, sized and selected in accordance with ASME standards to include a dual relief valve and rupture disc system to protect the pressure vessel, and a reverse buckling rupture disc or lift plate to protect the vacuum casing from over-pressure. While MVE equipment is designed and built to the most rigid standards, no piece of mechanical equipment can ever be 100% foolproof.

INSTALLATION

PLACEMENT OF SKID

The TRIFECTA . skid has three lifting lugs on the top of the skid. These lifting lugs allow for placement of the skid by overhead crane. If an overhead crane is not available, the skid has fork truck access in the front.

The TRIFECTA . skid should be placed on the concrete pad, near the bulk storage tank. It is preferred to put the skid as close to the bulk tank as possible without interfering with any other equipment or requirements of the tank. The system requires a transfer of liquid and gas between the bulk storage tank and the TRIFECTA . skid. This process will become more efficient as the skid moves closer to the bulk tank.

The skid should be placed such that there is easy access to the front of the skid so that one can easily check the Laser-Cyl's gauges, or the control box at any time. Consideration should also be given to where the optional external vaporizer will be placed on the pad.

PLUMBING TO BULK TANK

The TRIFECTA . skid needs to have one line plumbed to the bulk storage tank. This line will serve two functions. The first function is to allow the transfer of liquid from the bulk tank to the Laser-Cyl's in the filling process. The second function is to allow the initial venting of gas from the Laser-Cyl to the bulk tank. This gas is vented into the liquid of the bulk tank to minimize pressure rise in the bulk tank. This one line should be plumbed to an Auxiliary liquid line of the bulk tank. The recommended line size is no smaller than one inch. When looking at the back of the system skid, there are two connection points available for plumbing hook-up. The connection point on the left, labeled C-1 on Figure 2, is the one that should be plumbed to the bulk tank.

The line should be insulated for two reasons. The first reason is that an insulated line will allow more efficient liquid transfers and fills. The second reason is that when the Laser-Cyl vents gas to the bulk tank, it is undesirable for the venting gas to pick-up any additional heat on its way to the bulk tank. If the vent gas picks up additional heat, the bulk tank will experience greater pressure rise.



NOTE ON START-UP: It should be noted that there are no valves on the liquid inlet of the Trifecta system. The only valves on these lines are check valves to prevent back flow into the bulk tank. If the Laser-Cyls are at a pressure lower than the bulk tank, liquid will flow from the bulk tank to the Laser-Cyls until the pressure of the Laser-Cyls are the same as the bulk tank. As a result, the isolation valve on the bulk tank should not be opened until all plumbing connections are complete.

PLUMBING TO VAPORIZER

The Trifecta system does not contain an internal or external vaporizer. As a result, a freestanding, external vaporizer must be connected to the product delivery line of the Trifecta. This line should be plumbed with lines no smaller than ½ inch. Small lines will introduce undesirable pressure drops in the global gas system. Referring to Figure 2, Connection C-2 should be plumbed to the vaporizer. The exit of the vaporizer should be plumbed to the customer house line. When looking at the back of the system skid, there are four open ended lines. Two of these lines are the vent to atmosphere lines for either tank, and the other two are the bulk tank connector and the gas use. These are labeled. Excluding the two vent lines, the connection point on the right is the one that should be plumbed to the vaporizer. This is the gas use line.

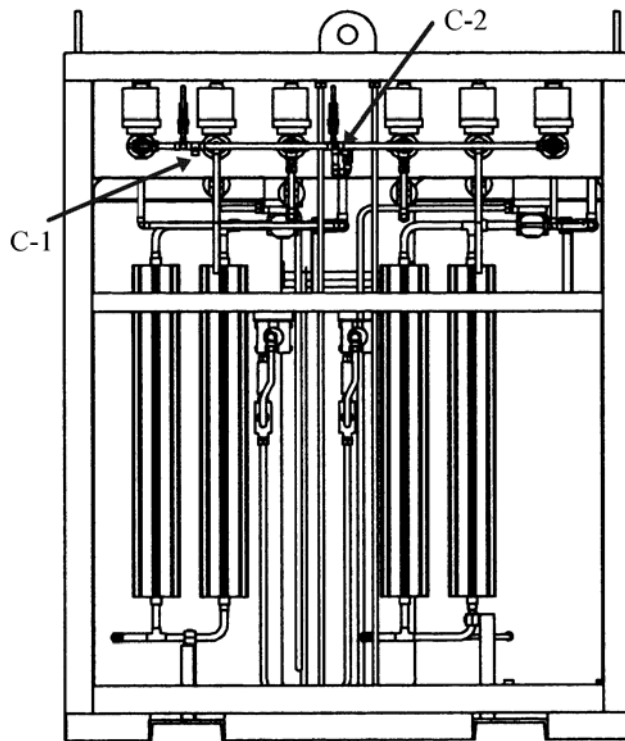

Figure 2 - Plumbing Connection Points

BULK TANK PRESSURE TRANSMITTER

The system controller requires the pressure input of the bulk tank to perform the filling procedure as efficiently as possible. This is done through a pressure transmitter. The pressure transmitter will measure the pressure of the bulk tank and send an electrical signal back to the controller. The transmitter for the bulk tank is shipped inside the control box.

Plumbing

The transmitter should be installed anywhere such that it senses the bulk tank vapor pressure. A convenient place for installation is the vapor phase line. If the transmitter is installed in the vent circuit, care should be taken to ensure that the pressure to the transmitter is not removed. This may happen in systems with a dual relief circuit as the diverter valve is changed from one side to another. For this reason, we recommend installing the transmitter to the vapor phase line.

Electrical

The transmitter needs to be wired to the controller. The transmitter wires should be run into the control box through one of the extra conduit holes in the bottom of the control box. The transmitter has two available wires. These wires should be connected as follows:

- Red = Transmitter positive
- Blue = Transmitter negative

We recommend using a *shielded cable* to connect the transmitter to the controls. Shielded cable helps protect the signal and the transmitter from any electric noise. This electric noise could cause the controller to read the transmitter's signal incorrectly. The shield of the cable should be grounded on one end only. This can be grounded to the conduit or inside the control box on one of the mounting screws. A convenient place to ground it is to the ground wire of the transmitter. It is very important that it is not grounded on both ends of the shield.

The *red* transmitter wire should be connected to terminal number 113 as shown in the following figure. The *blue* transmitter wire should be connected terminal number 205 as shown in the figure on the following page.



Conduit must be run all the way to the threads on the back end of the transmitter. The connection of the cord to the transmitter is not water-proof. Running conduit to the back threads will keep this connection dry and working properly.

ELECTRICAL POWER SUPPLY

The TRIFECTA . system requires 20 Amperes of current at 110vac. The power should be run into the control box through one of the extra conduit holes provided on the bottom of the control box. For installation convenience, three (3) gray terminals are provided on the bottom right corner of the control panel for power supply hook-up. As Figure 3 indicates, the first of the gray terminals (from the left)² is for the hot (black) wire of the power. The second terminal is for the neutral (white) wire of the power and the last gray terminal is for the ground (green) wire of the 110vac power supply. This is all of the power wiring that is needed. All other power wiring has been completed at the factory.

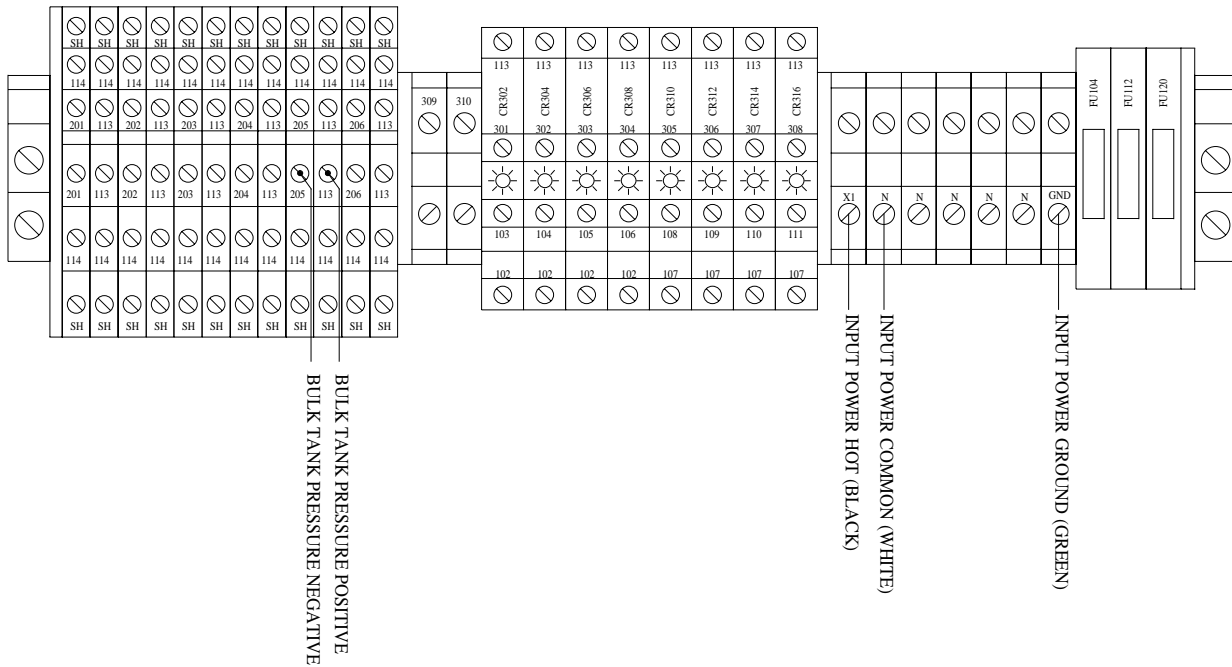

Figure 3 - Field Wiring Diagram

It is important that care is taken to install the Trifecta system on an electrical power circuit that is clean and protected. Circuits that are susceptible to noise and brown-outs may cause erratic behavior from the system. Care should also be taken to not install the system on a circuit that regularly gets shut on and off to provide power to another piece of equipment (lights, heaters, cooling systems etc.). It should be recognized that a PLC (computer) controls the Trifecta system and a circuit similar to that which would be used to power a personal computer should be used to power the Trifecta system.

It is recommended that the Trifecta system be powered by a dedicated circuit that is clean and protected to minimize the chances or occurrences of electrical noise, power surges or brown-outs.

COMMISSIONING

² Starting on the right side of the relays.

It is suggested, as with any new gas supply equipment, that all fittings be leak checked with a bubble solution. Although the system is pressure tested at the factory, it is not uncommon for threaded fittings to vibrate loose during over the road shipment.

It is also suggested that the system be purged with warm, dry nitrogen before running the system with liquid.

OPERATION

AUTOMATIC MODE



NOTE: In automatic mode, all manual By-Pass feature on solenoid valves **MUST** be in the closed position. (Handle away from body of valve.)

To operate the system in automatic mode, simply turn the power switch located on the control box door to the “ON” position. When the power is turned on, the controller will go through an initialization routine to determine which tank is going to be used first, or if either or both need filling. It is important to verify that all valves are open or closed, according to the following table.

If the system has been shut off, upon turning the power back on, the controller will go through the initialization routine and begin controlling. Nothing is lost when the controller is turned off. The system does not have to be turned off in periods of no use (over-night, weekends etc.). Turning the system off will de-energize the solenoids and may be advantageous if the system is not going to be used for an extended period of time (greater than four days). However, this is not necessary as the system will continue to monitor itself and maintain pressures and liquid levels such that it is ready for immediate service. When looking at the front of the skid, the Laser-Cyl on the right is considered Tank #1³. If using the Trifecta 450 system, the manual valves on the Laser-Cyls should be according to the following table for automatic operation.

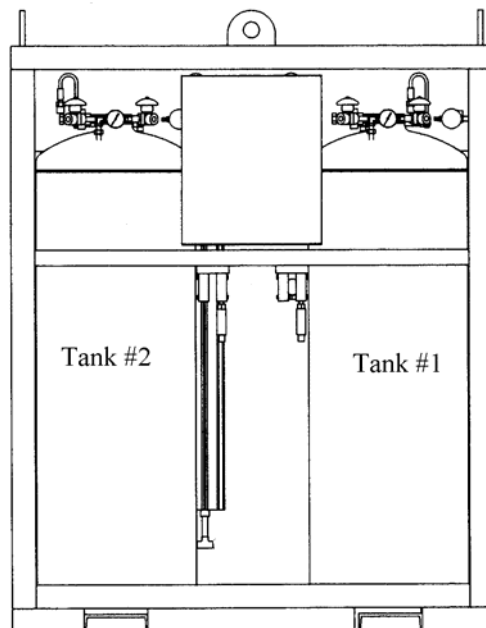

Figure 4 - System Front View

³ Applies to Trifecta 450 systems.

Table 1 - Valve Operating Positions

TANK	APPLICABLE SYSTEM	VALVE	POSITION
Bulk Tank	200L and 450L	Auxiliary Liquid	Open
Laser-Cyl Tank #1	450L	Vent	Open
Laser-Cyl Tank #1	450L	Gas Use	Open
Laser-Cyl Tank #1	450L	Liquid	Open
Laser-Cyl Tank #1	450L	<i>Internal Pressure Builder</i>	Closed
Laser-Cyl Tank #2	450L	Vent	Open
Laser-Cyl Tank #2	450L	Gas Use	Open
Laser-Cyl Tank #2	450L	Liquid	Open
Laser-Cyl Tank #2	450L	<i>Internal Pressure Builder</i>	Closed
All By-Pass Valves	200L and 450L	Valve Panel	Closed - Handle down

The manual by-pass feature on the solenoid valve operates such that turning the valve handle in (closer to the valve body) will open the valve. Turning the valve handle out (away from the valve body) will close the valve. This is also labeled on the valve handle.

PLC CONTROLLER INTERFACE

The Trifecta system is controlled by a Programmable Logic Controller (PLC) that has a keypad interface. The software in the controller allows you to set up the system for your particular needs. It is anticipated that this will be used upon initial start-up, and not much after that, but it is available at any time. The controller allows you to configure the following parameters:

- **Operating Pressure** - This pressure is the low pressure that will cause the pressure builder to start. The pressure builder will come on when the Laser-Cyl reaches this pressure and build pressure up to 20 psig above the operating pressure.
- **Tank Choice** - This should be set to indicate if your system is using Laser-Cyl 450L or Laser-Cyl 200L.
- **Bulk Tank Critical** - At the start of the filling process, the Laser-Cyl will vent its gas into the bulk tank to conserve product *if* the pressure in the bulk tank is *less* than this value. If the pressure in the bulk tank is greater than this value, it will vent to atmosphere. This also applies to the over pressure condition.
- **Over Pressure** - If the pressure in the Laser-Cyl is *above* this value, it will vent product either to the bulk tank or to the atmosphere (according to Bulk Tank Critical). This is intended for safety purposes and to reduce the risk of relief valves opening.

These values have pre-programmed minimums and maximums. The following table shows the respective minimum, maximum and default value for each of the variables.

Table 2 - Configurable Values

VARIABLE	DEFAULT VALUE	MINIMUM	MAXIMUM
Operating Pressure	425 psig	20 psig	475 psig
Tank Choice	450L	200L	450L
Bulk Tank Critical	150 psig	35 psig	245 psig
Over Pressure	480 psig	Operating Pressure + 22 psig	499 psig

Changing Parameters



When entering the Set-up Menu, the system will shut down and all valves will close. This should only be done in a time of service such that the end use is not immediately dependent on gas flow. Product will start being delivered upon exiting the Set-up Menu.

The Set-up Menu can be obtained by pressing the “menu” key on the keypad⁴ (Note: If the system is in a fill mode, the menu is inaccessible). After pressing the “menu” key, the LCD display will prompt you to “Press F1 for Values.” Repeatedly pressing the “F1” key will toggle through the list of values. In addition to the changeable values shown above, it also displays the readings of the pressure and differential pressure transmitters. This may be useful in troubleshooting as you can verify the transmitters are reading the same as the analog gauges on the tanks.

When you press the “F1” key and one of the changeable parameters from the above table is displayed, the value can be changed by pressing the “♦” (up) and “◆” (down) keys on the keypad. When the value has changed to the desired value, pressing “F1” will bring you to the next value. When all values are satisfactory, pressing the “menu” key will exit the Set-up Menu and return the system to operation based on the new values.

If the system is turned off, all of the parameters are stored in memory. When the system is turned back on, the controller will resume operation based on the most current values. The values will not need to be re-configured each time it is turned on.

MANUAL MODE

If power is lost to the system, all of the solenoid valves will close. To run the system, manually operate the solenoid valves by turning the valve handle on the bottom of the valve to provide flow as required. The operator will have to pick a tank to use and open its gas use and pressure building valve. It is important to note that when the system is running in manual mode, the pressure building valve on the Laser-Cyl will need to be opened **and monitored**. If the loss of power continues and a tank needs to be filled, the

⁴ “Menu” key is disabled during the filling of a Laser-Cyl.

operator will need to close the previous tank's gas use and pressure building valves, and open the other tank's gas use and pressure building valves. To fill the tank, the operator needs to control the vent of the Laser-Cyl to remain below the pressure of the bulk tank by operating the vent to atmosphere valve. When the pressure is lower than the bulk tank, liquid will flow into the tank through the check valve. The Laser-Cyls should be filled to 27 inches of water as shown on the liquid level gauges

The manual by-pass feature of the solenoids is operated such that turning the valve handle in (closer to the valve body) will open the valve and allow flow. Turning the valve handle out (away from the valve body) will close the valve and stop flow.



NOTE: It is ***EXTREMELY*** important that if the system is run in manual mode, the pressure building valve not be opened and left unattended. The pressure building circuit does not have any regulators or control devices. If the valve is left open, rapid, uncontrolled pressure rise may occur. Since there is no power, the PLC controller will not be available to control the pressure. The Laser-Cyl relief valve and rupture disk will potentially open to relieve the pressure. The system should only be operated this way for brief periods of time until power can be restored. While operating this in this mode, someone should closely monitor the pressure of the tank and close the pressure building valve if the pressure rises more than desired.

The following figure and table illustrate the valves and their function:

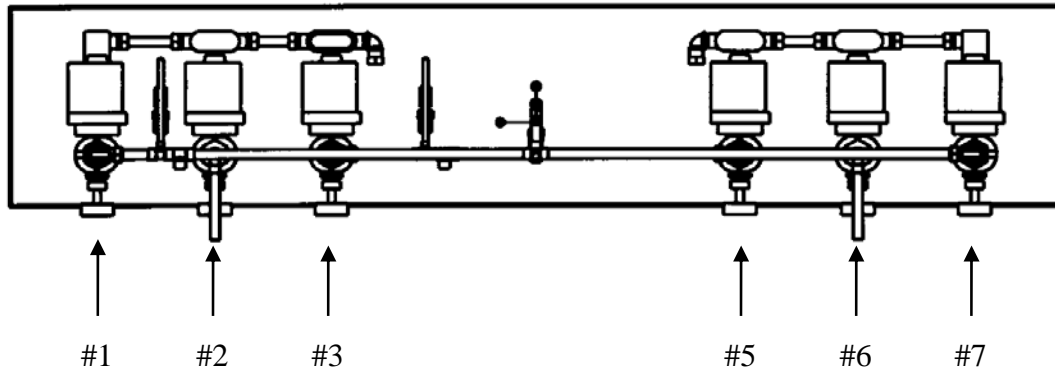

Figure 5 - Valve Identification

The following table identifies the valves shown in the above diagram:

Table 3 - Valve Identification

Valve Number	Valve Description
#1	Vent to bulk tank - Tank #1
#2	Vent to atmosphere - Tank #1
#3	Gas use - Tank #1
#5	Gas Use - Tank #2
#6	Vent to atmosphere - Tank #2
#7	Vent to bulk tank - Tank #2

Valves #4 and #8 are the pressure building valves for Tank #1 and Tank #2 respectfully. These valves are not on the panel, but are mounted on the top of the pressure building coil next to the respective Laser-Cyl.

REPLACEMENT PARTS

SOLENOID VALVES

The solenoid valves that are used in this system have very long life and valve failure or replacement is highly unlikely. In the unlikely event that a valve needs to be repaired, the following table gives the part number of the valve. It is generally not necessary to remove the valve body, but only replace the top works of the valve.

Table 4 - Solenoid Valves

Valve Manufacture	MVE, Inc. Part Number
Magnatrol	10925509

If the whole valve is not required, there are repair kits available for various parts of the valve. The following table lists the available repair kits for these valves:

Table 5 - Solenoid Valve Repair Kits

Repair Kit	MVE, Inc. Part Number
Solenoid Coil (120 vac)	10963071
Piston Assembly	10963062
Gasket	10963100

PRESSURE/DIFFERENTIAL PRESSURE TRANSMITTERS

There are five (5) transmitters in the TRIFECTA system. Two (2) of the transmitters are measuring differential pressure of each of the Laser-Cyls. This is to provide a measure of liquid level. The other three (3) transmitters are pressure transmitters. The five (5) transmitters are used to provide pressure and liquid level information to the PLC for controlling purposes. The following table lists the specifications for the transmitters used.

Table 6 - Transmitters

Transmitter Type	Service	Span	Output	MVE, Inc. Part Number
Differential Pressure	Inert	0-100" W.C	4-20 mA	10831051
Pressure	Inert	0-500 psig	4-20 mA	10890166
Differential Pressure	Oxygen	0-100" W.C	4-20 mA	10942368
Pressure	Oxygen	0-500 psig	4-20 mA	10947249

LASER-CYL PRESSURE SAFETY DEVICES

Each Laser-Cyl in this system has its own pressure relief safety system. They each have a relief valve and a rupture disc. The following table is a list of the specifications on these devices.

Table 7 - Line Relief Valves

Part	Size	Set Pressure	MVE, Inc. Part Number
Relief Valve	1/2" MPT	500 psig	11030264
Rupture Disc	1/4" MPT	500 psig	1911072

LINE RELIEF VALVES

The system has many line relief valves. These relief valves protect against the accidental closing of two valves with trapped liquid between them. The line relief valves are installed on "candy-canes" to help keep the valve at warmer temperatures. Table 8 lists the specifications of the line relief valves used.

Table 8 - Line Relief Valves

Valve Manufacture	Size	Set Pressure	MVE, Inc. Part Number
Rego	1/4" MPT	550 psig	1812702

FUSES

The control box has three (3) fuse holder terminal blocks. These blocks are black and have a lift open door. The power to the system should be turned off when checking or replacing fuses. To replace or check a fuse, lift the door open and slide the fuse out of the holder. Slide the new fuse in place and snap the door back into place. The following table lists the specifications of the fuses in use. The following figure illustrates the location of the fuses.

Table 9 - Fuses

Fuse Type	Size	Capacity	MVE, Inc. Part Number
AGC-10	1/4 inch * 1 inch	10 Amperes	AAA0205
AGC-5	1/4 inch * 1 inch	5 Amperes	AAA0204

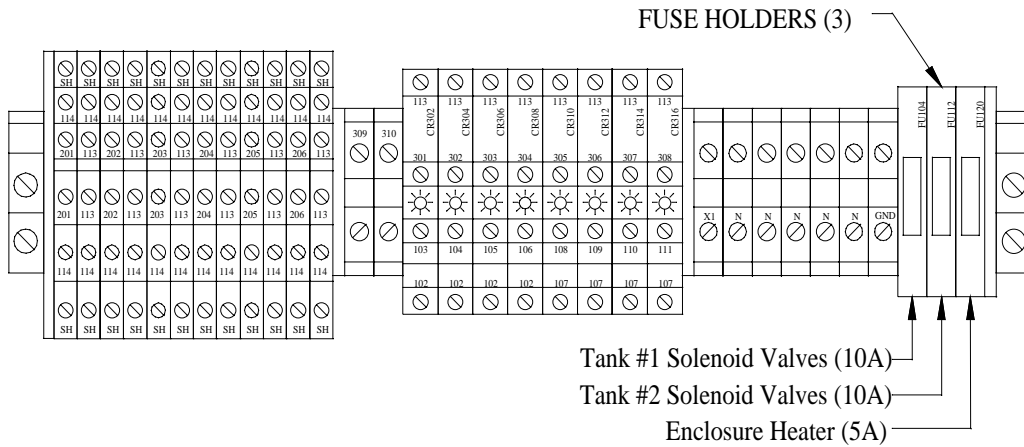

Figure 6 - Fuse Location Diagram

RESISTOR ELEMENTS

The control circuit utilizes precision resistor elements to convert the transmitters' 4-20mA current signal to a voltage for the controller to read. The resistors are 500 Ohms and have very tight tolerances. If a resistor does not measure 500 Ohms within 0.5 Ohms, a new resistor should be installed. The following table lists the resistor information:

Table 10 - Resistor Elements

Resistance Value	Tolerance	MVE, Inc. Part Number
500 Ohm	0.1%	10965691

RELAYS

The control system contains eight (8) relays that control the solenoid valves on the system. The eight relays are a 5A contact rated relay. All of the relays have white LEDs that indicate whether or not the relay is currently energized. Although these LEDs provide good, quick indication of whether or not the relay is working, it is not proof that the relay contacts are operating. Figure 7 illustrates which relays control which solenoid valves. The following table lists the specifications for the relays:

Table 11 - Relays

Relay Type	Contact Rating	Coil Voltage	MVE, Inc. Part Number
Normally Open	5 Amperes	24 vdc	10878028

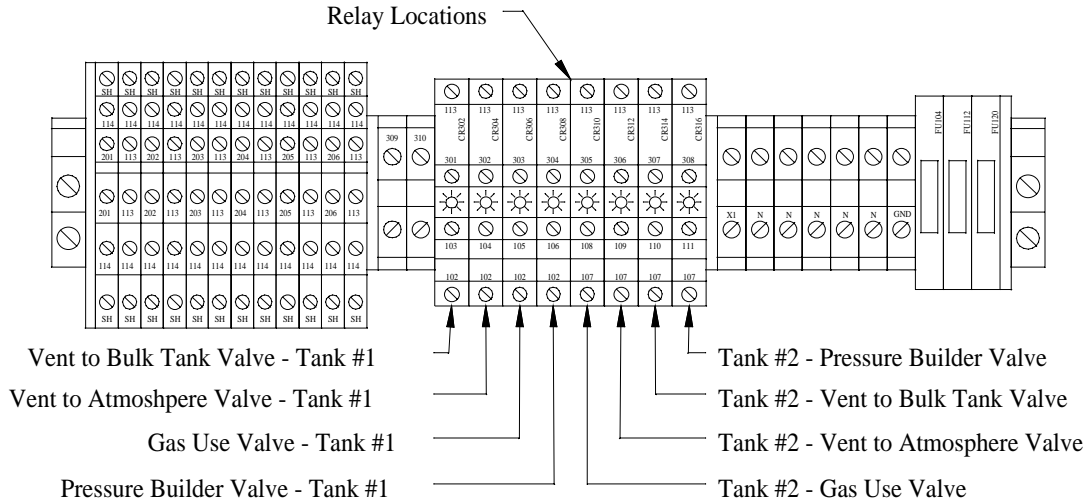

Figure 7 - Relay Identification Drawing

TROUBLESHOOTING

SENSOR ERROR CHECK

The PLC does a constant check on all five transmitters. If a transmitter were to come disconnected, or some other catastrophic failure, the PLC will detect it. When the PLC detects such a failure, it will shut the entire system down and display the following warning message on the LCD display:

Sensor Connection
Error.....Press F1

After pressing the “F1” key on the keypad, the LCD display will tell you which transmitter has developed the problem and then prompt you to press the “menu” key when done. A sample message may be:

Check: Tank 1 Press.
Press menu when done

This would imply that the pressure transmitter for Tank #1⁵ is the source of the error. After fixing the problem, pressing the “menu” key will return the system to normal operation. If the problem is not fixed and the “menu” key is pressed, or if there is a second transmitter that needs attention, it will display the original Sensor Connection Error message again. Pressing the “F1” key will tell you which transmitter needs attention.

Sensor Error Solutions

⁵ Tank #1 is the tank on the right when looking at the front of the control box.

The sensor error check function is designed to find problems such as a wire coming disconnected, or a short in the transmitter. This feature will not determine if the transmitter reading is off by any amount. If a Sensor Connection Error occurs, check the wire junctions at the transmitter end and inside the control box. Confirm that all connections are made. If all connections are made and the error condition does not go away, check the transmitter output as shown in the Checking Transmitter Output section.

PRODUCT DELIVERY

The following Table lists possible problems and causes.

Table 12 - Troubleshooting

Problem	Possible Cause	Remedy
Laser-Cyl's don't fill	Power not on.	Turn power on.
	Bulk tank auxiliary liquid valve not open.	Open bulk tank auxiliary liquid valve
	Laser-Cyl liquid valve not open.	Open Laser-Cyl liquid valve.
	Fill solenoid valve not opening	Check relay.
		Repair solenoid.
	No pressure in bulk tank.	Build pressure in bulk tank.
	Vent to atmosphere solenoid valve not opening	Check relay.
		Repair solenoid.
	Leak in phase lines.	Repair leaks.
Transmitters faulty.	Replace transmitter.	
Gas not being delivered	Power not on.	Turn power on.
	Laser-Cyl gas use valve not open. ⁶	Open Laser-Cyl gas use valve.
	Laser-Cyls empty.	See above section.
	Gas use solenoid valve not opening.	Check relay.
Repair gas use solenoid valve.		
Controller Continuously Beeps	Code has been displaced from memory.	Turn power off, wait a minute and turn it back on.
		Consult factory.

CHECKING TRANSMITTER OUTPUT

⁶ Applies to Trifecta 450 system.

If the transmitters are suspected of giving incorrect readings, the output can be checked while the system is running⁷. The bottom of the PLC controller has input channels U1-U6. The channels are assigned according to the following table, and can be located according to the following figure.

Table 13 - PLC Input Channels

Input Channel	Measurement
U1	Liquid Level - Tank #1
U2	Liquid Level - Tank #2
U3	Pressure - Tank #1
U4	Pressure - Tank #2
U5	Pressure - Bulk Tank
U6	Not Used

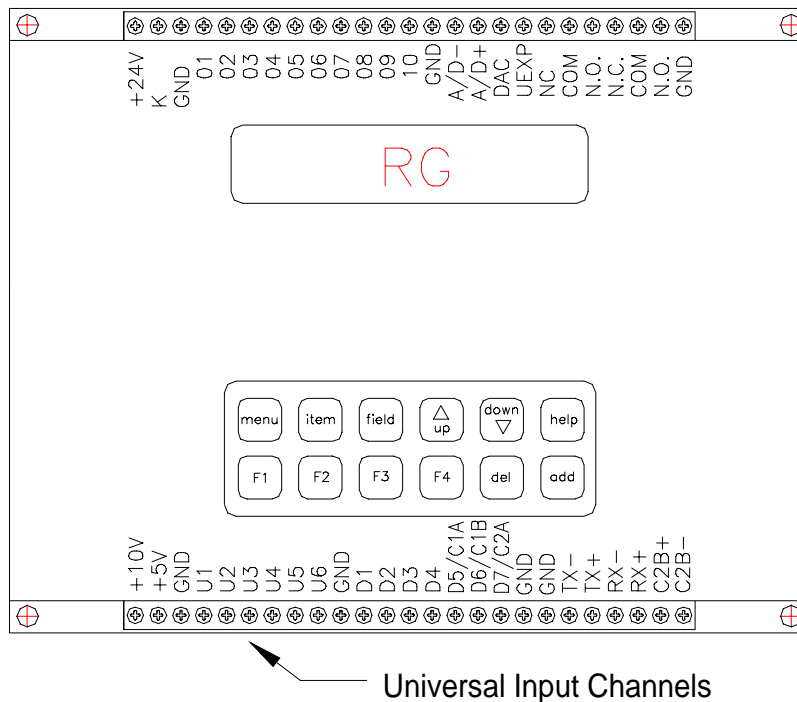

Figure 8 - Input Channel Location on the PLC

⁷ This can also be done by pressing the “menu” button on the PLC keypad and toggling through the readings with the F1 button. This is described in the PLC Controller Interface Section.

Pressure Transmitter

To check a pressure transmitter, measure the voltage from the appropriate input channel to the terminal GND. The probes of the voltmeter can be placed directly on the terminal screw heads. Either of the two GND terminals can be used as they are common internally to the PLC. With the measured voltage, calculate the pressure by the following equation:

$$\text{Pressure} = \left(\frac{\text{Voltage} \times 2 - 4}{16} \right) \times 500$$

For example, if the voltage measured between U5 and GND was 3.600 volts on a system in nitrogen or argon service, it would mean that the bulk tank should be at a pressure of:

$$\text{Pressure} = \left(\frac{3.600 \times 2 - 4}{16} \right) \times 500 = 100 \text{psig}$$

If the pressure gauge on the bulk tank does not read approximately 100 psig, there is a possibility that the transmitter is not functioning properly.

Differential Pressure Transmitter

To check a differential pressure transmitter, measure the voltage from the appropriate input channel to GND. The probes of the voltmeter can be placed directly on the terminal screw heads. Either of the two GND terminals can be used as they are common internally to the PLC. With the measured voltage, calculate the differential pressure by the following equation:

$$\text{Differential Pressure} = \left(\frac{\text{Voltage} \times 2 - 4}{16} \right) \times 100$$

For example, if the voltage measured between U1 and GND was 3.200 volts, it would mean that the liquid level of Laser-Cyl #1 is:

$$\text{Differential Pressure} = \left(\frac{3.200 \times 2 - 4}{16} \right) \times 100 = 15 \text{ inches of water}$$

If the liquid level gauge on Laser-Cyl #1 does not read approximately 15 inches of water, there is a possibility that the transmitter is not functioning properly.

Note that the transmitter and gauge readings may not match exactly.

CHECKING RESISTOR VALUES

Each transmitter utilizes a resistor element to convert its 4-20mA current signal to a voltage. These resistors should have a value of 500 Ohms. To check the resistors, it is important to isolate the resistor from the controller and the transmitter. This can be done by removing the resistor itself and measuring its value independent of the system. To pull the resistors out of the control circuit, loosen the screws of the terminals listed in the following table and remove the resistor. When replacing the resistor, be sure to place it in the same terminals as it was taken from. If the resistor is placed in the wrong terminals, or the terminals are not tight, the system will not operate correctly.

Table 14 - Resistor Removal Terminals

Sensor	Terminal #1	Terminal #2
Liquid Level - Tank #1	201	114
Liquid Level - Tank #2	202	114
Pressure - Tank #1	203	114
Pressure - Tank #2	204	114
Bulk Tank Pressure	205	114

Note that there are multiple terminals labeled #114. Use the #114 terminal that is directly below terminal #1 as shown in the above table. For example, if testing the resistor for the liquid level sensor of Tank #2, loosen screw terminals #202 and #114 (directly below #202). This will allow the resistor to be removed. The resistor can then be measured for its value. It is obviously extremely important that the resistor be returned to its original position when re-installing it.

RECOMMENDED SPARES

The following table lists the recommended spare parts to have on hand:

Table 15 - Recommended Spares

PART	MVE, Inc. Part Number	Quantity
Line Relief Valve	1812702	2
Solenoid Valve	10925509	1
Relay	10878028	1
Fuse (5 Amp)	AAA0204	2
Fuse (10 Amp)	AAA0205	2
Laser-Cyl Relief Valve	11030264	1
Laser-Cyl Rupture Disc	1911072	1

WARRANTY

The Trifecta system comes with a system warranty of 90 days. In addition, the vacuum on the individual tanks is five (5) years, and the Manufacturers' warranties will be passed on for the following components:

Table 16 - Component Manufacture's Warranties

COMPONENT	MANUFACTURE'S WARRANTY
PLC	90 Days
DC Power Supply	1 Year
Relays	1 Year
Differential Pressure Transmitter	2 Years
Pressure Transmitter	1 Year
Solenoid Valve	1 Year
Check Valve	1 Year
Differential Pressure Gauge	1 Year

DRAWING APPENDIX

C-10928849

D-10923562 SHEET 2 AND SHEET 4